

2

1

B

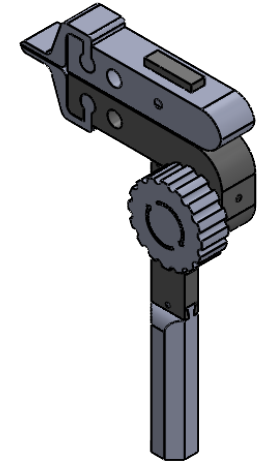
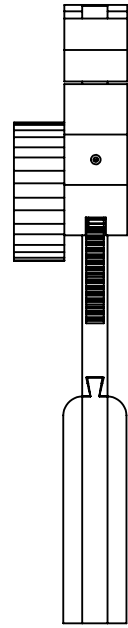
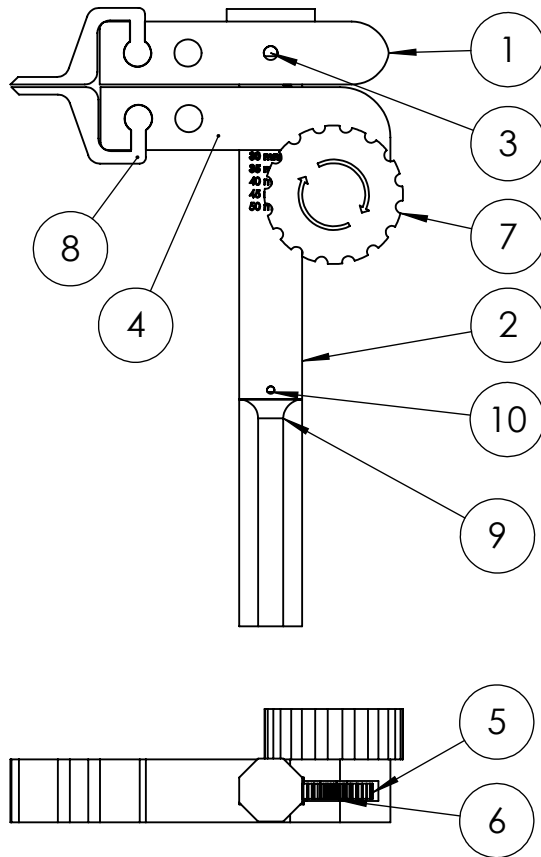

B

A

ITEM NO.	PART NUMBER	DESCRIPTION	QTY.
1	TopMember	Top Body of Device	1
2	Ruler	Ruler that Is used to measure Incisor opening (mm)	1
3	RetainerPin	Pin That Retains Ruler to Top Body	1
4	BottomMember	Bottom Body of Device	1
5	Gear	Converts rotation to linear motion	1
6	DialPartOne	Cover for Other End of Dial	1
7	DialPartTwo	Turn Dial That Opens Device	1
8	MouthPiece	Mouthpieces That Interact With Patient	2
9	Handle	Ergonomic Device-Human Interface	1
10	HandlePin	Fixes Handle to Ruler	1

A

2

1

B

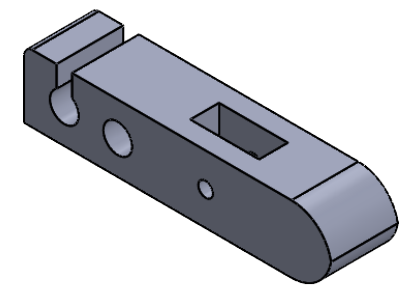

B

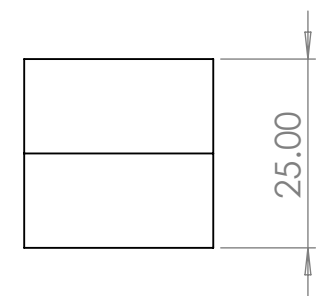
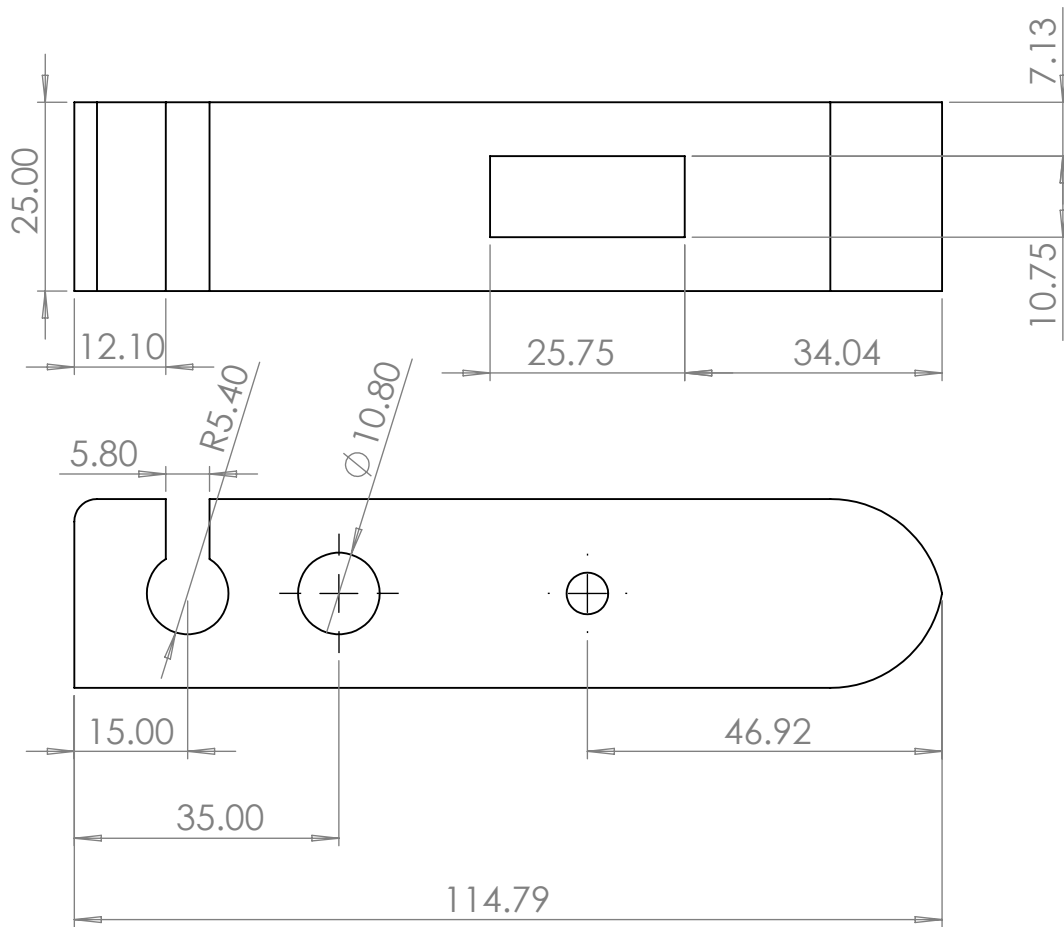

A

A

PROPRIETARY AND CONFIDENTIAL
 THE INFORMATION CONTAINED IN THIS DRAWING IS THE SOLE PROPERTY OF <INSERT COMPANY NAME HERE>. ANY REPRODUCTION IN PART OR AS A WHOLE WITHOUT THE WRITTEN PERMISSION OF <INSERT COMPANY NAME HERE> IS PROHIBITED.

		UNLESS OTHERWISE SPECIFIED:		NAME	DATE
		DIMENSIONS ARE IN MILLIMETERS	DRAWN	CRR354	11/22/24
			CHECKED		
			ENG APPR.		
			MFG APPR.		
		INTERPRET GEOMETRIC TOLERANCING PER:	Q.A.		
		MATERIAL	COMMENTS:		
		PCTG			
		FINISH			
NEXT ASSY	USED ON				
APPLICATION		DO NOT SCALE DRAWING			

TITLE:		
Top Member		
SIZE	DWG. NO.	REV
A	01	
SCALE: 1:1	WEIGHT:	SHEET 2 OF 11

2

1

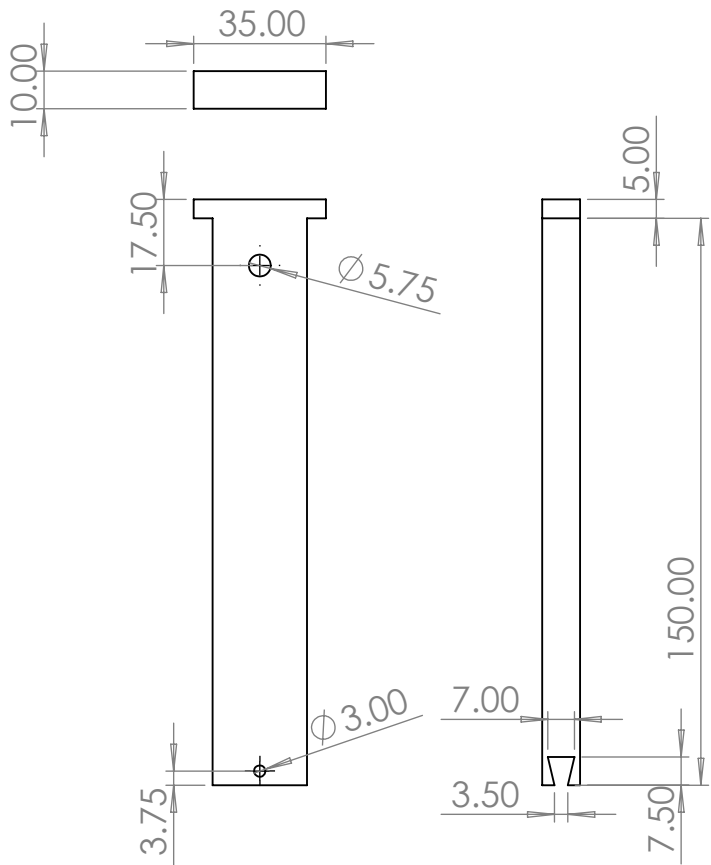

B

B

A

A

PROPRIETARY AND CONFIDENTIAL
 THE INFORMATION CONTAINED IN THIS DRAWING IS THE SOLE PROPERTY OF <INSERT COMPANY NAME HERE>. ANY REPRODUCTION IN PART OR AS A WHOLE WITHOUT THE WRITTEN PERMISSION OF <INSERT COMPANY NAME HERE> IS PROHIBITED.

		UNLESS OTHERWISE SPECIFIED:		NAME	DATE
		DIMENSIONS ARE IN MILLIMETERS	DRAWN	CRR354	11/22/24
			CHECKED		
			ENG APPR.		
			MFG APPR.		
		INTERPRET GEOMETRIC TOLERANCING PER:	Q.A.		
		MATERIAL	COMMENTS:		
		PCTG			
		FINISH			
NEXT ASSY	USED ON				
APPLICATION		DO NOT SCALE DRAWING			

TITLE:		
Ruler		
SIZE	DWG. NO.	REV
A	02	
SCALE: 1:2	WEIGHT:	SHEET 3 OF 11

2

1

B

B

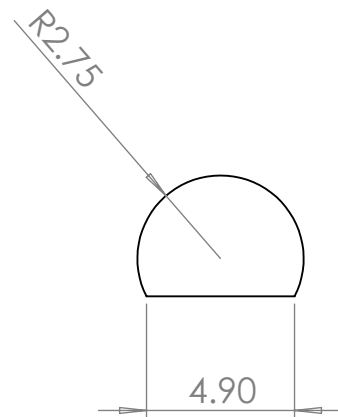
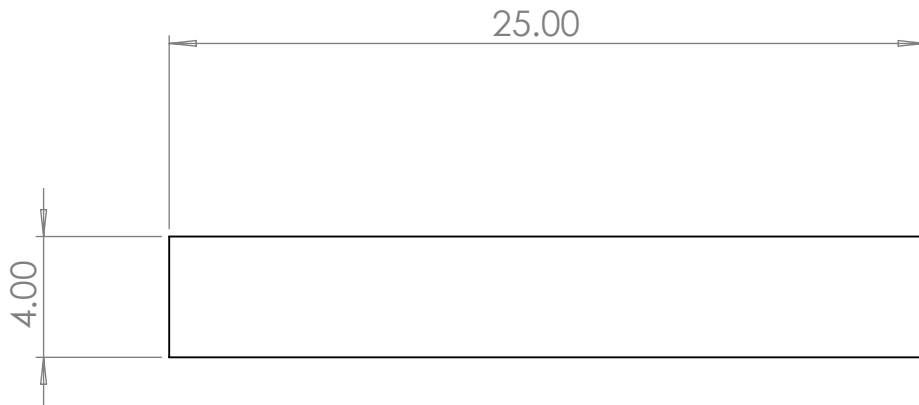
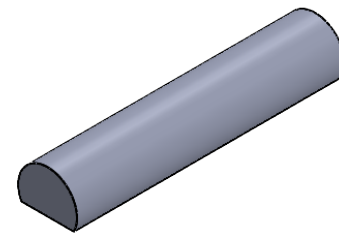

A

A

PROPRIETARY AND CONFIDENTIAL
 THE INFORMATION CONTAINED IN THIS DRAWING IS THE SOLE PROPERTY OF <INSERT COMPANY NAME HERE>. ANY REPRODUCTION IN PART OR AS A WHOLE WITHOUT THE WRITTEN PERMISSION OF <INSERT COMPANY NAME HERE> IS PROHIBITED.

		UNLESS OTHERWISE SPECIFIED:		NAME	DATE
		DIMENSIONS ARE IN MILLIMETERS	DRAWN	CRR354	11/22/24
			CHECKED		
			ENG APPR.		
			MFG APPR.		
		INTERPRET GEOMETRIC TOLERANCING PER:	Q.A.		
		MATERIAL	COMMENTS:		
		PCTG			
NEXT ASSY	USED ON	FINISH			
APPLICATION		DO NOT SCALE DRAWING			

TITLE:		
RetainerPin		
SIZE	DWG. NO.	REV
A	03	
SCALE: 4:1	WEIGHT:	SHEET 4 OF 11

2

1

B

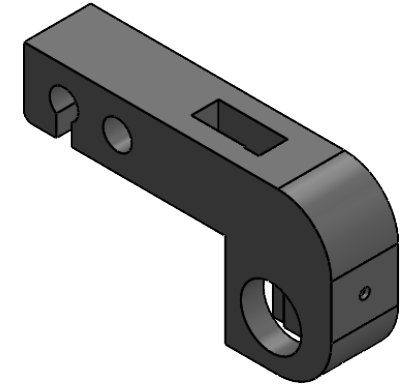
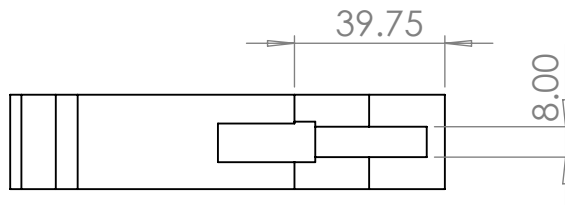
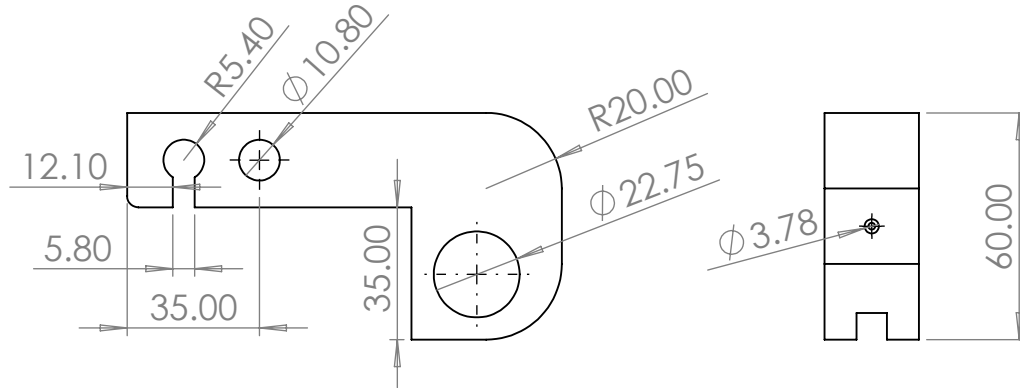
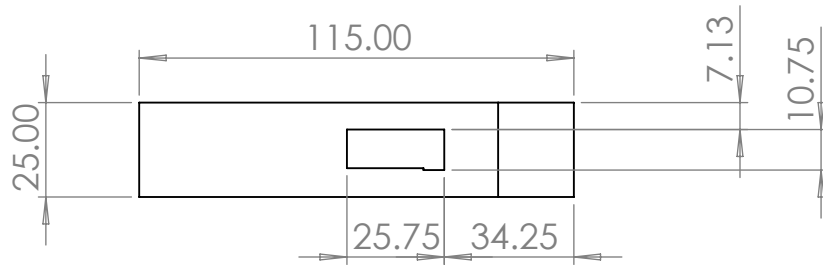

B

A

<p>PROPRIETARY AND CONFIDENTIAL THE INFORMATION CONTAINED IN THIS DRAWING IS THE SOLE PROPERTY OF <INSERT COMPANY NAME HERE>. ANY REPRODUCTION IN PART OR AS A WHOLE WITHOUT THE WRITTEN PERMISSION OF <INSERT COMPANY NAME HERE> IS PROHIBITED.</p>			UNLESS OTHERWISE SPECIFIED:		NAME	DATE	<p>TITLE: BottomMember</p>	
			DIMENSIONS ARE IN MILLIMETERS	DRAWN	CRR354	11/22/24		
					CHECKED			
					ENG APPR.			
					MFG APPR.			
			INTERPRET GEOMETRIC TOLERANCING PER:		Q.A.		<p>SIZE DWG. NO. REV</p> <p>A 04</p>	
			MATERIAL PCTG	COMMENTS:				
			FINISH					
	NEXT ASSY	USED ON	APPLICATION	DO NOT SCALE DRAWING			SCALE: 1:1 WEIGHT: SHEET 5 OF 11	

A

2

1

2

1

B

B

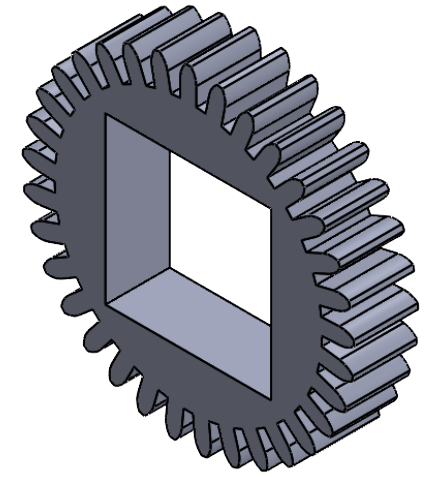
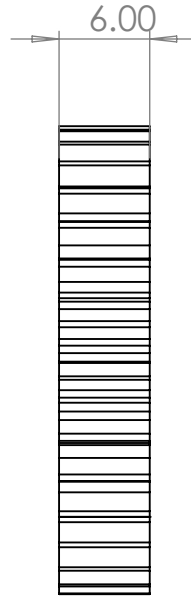
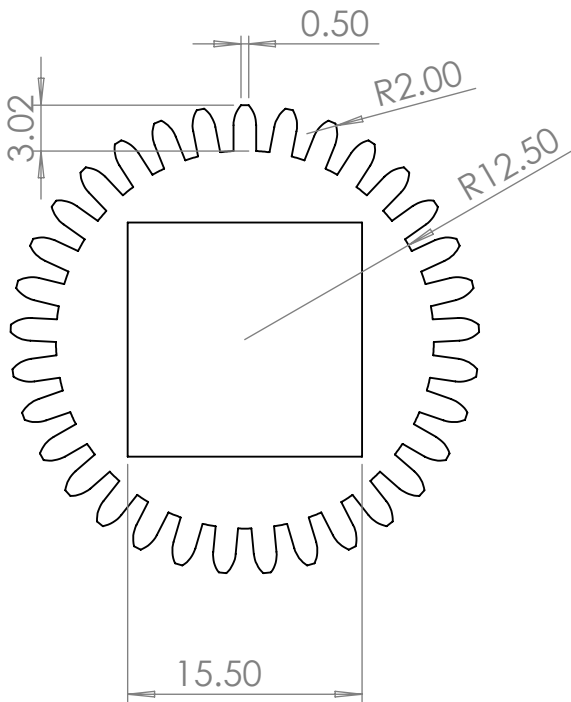

A

A

PROPRIETARY AND CONFIDENTIAL
 THE INFORMATION CONTAINED IN THIS DRAWING IS THE SOLE PROPERTY OF <INSERT COMPANY NAME HERE>. ANY REPRODUCTION IN PART OR AS A WHOLE WITHOUT THE WRITTEN PERMISSION OF <INSERT COMPANY NAME HERE> IS PROHIBITED.

		UNLESS OTHERWISE SPECIFIED:		NAME	DATE
		DIMENSIONS ARE IN MILLIMETERS	DRAWN	CRR354	11/22/24
			CHECKED		
			ENG APPR.		
			MFG APPR.		
		INTERPRET GEOMETRIC TOLERANCING PER:	Q.A.		
		MATERIAL	COMMENTS:		
		PCTG			
		FINISH			
NEXT ASSY	USED ON				
APPLICATION		DO NOT SCALE DRAWING			

TITLE:		
Gear		
SIZE	DWG. NO.	REV
A	05	
SCALE: 2:1	WEIGHT:	SHEET 6 OF 11

2

1

2

1

B

B

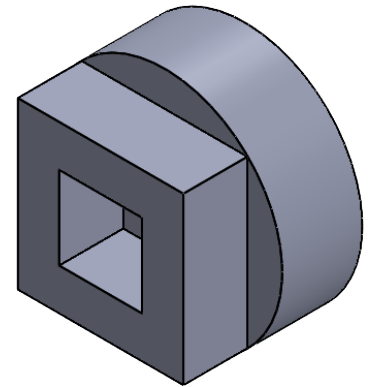
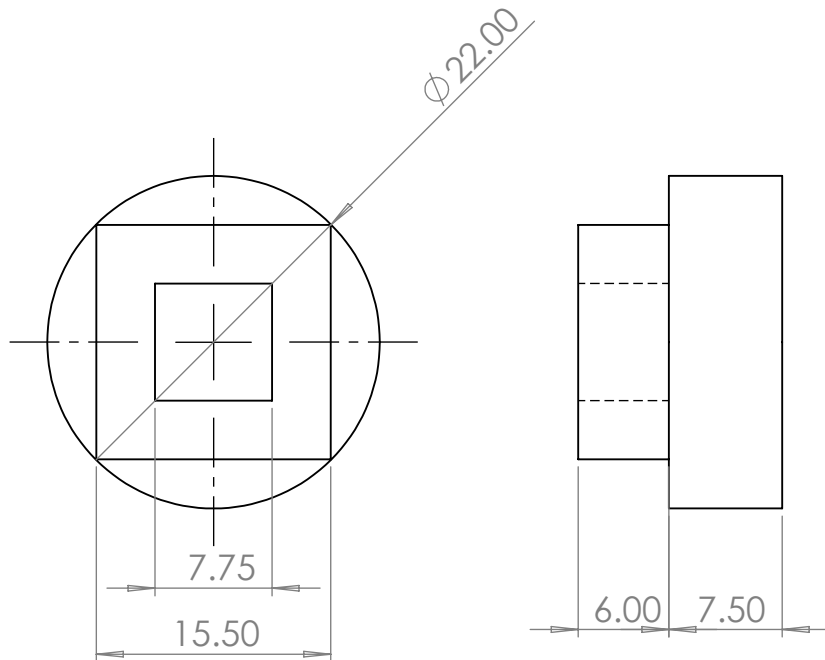

A

A

PROPRIETARY AND CONFIDENTIAL
 THE INFORMATION CONTAINED IN THIS DRAWING IS THE SOLE PROPERTY OF <INSERT COMPANY NAME HERE>. ANY REPRODUCTION IN PART OR AS A WHOLE WITHOUT THE WRITTEN PERMISSION OF <INSERT COMPANY NAME HERE> IS PROHIBITED.

		UNLESS OTHERWISE SPECIFIED:		NAME	DATE
		DIMENSIONS ARE IN MILLIMETERS	DRAWN	CRR354	11/22/24
			CHECKED		
			ENG APPR.		
			MFG APPR.		
		INTERPRET GEOMETRIC TOLERANCING PER:	Q.A.		
		MATERIAL	COMMENTS:		
		PCTG			
		FINISH			
NEXT ASSY	USED ON	APPLICATION	DO NOT SCALE DRAWING		

TITLE:		
DialPartOne		
SIZE	DWG. NO.	REV
A	06	
SCALE: 2:1	WEIGHT:	SHEET 7 OF 11

2

1

B

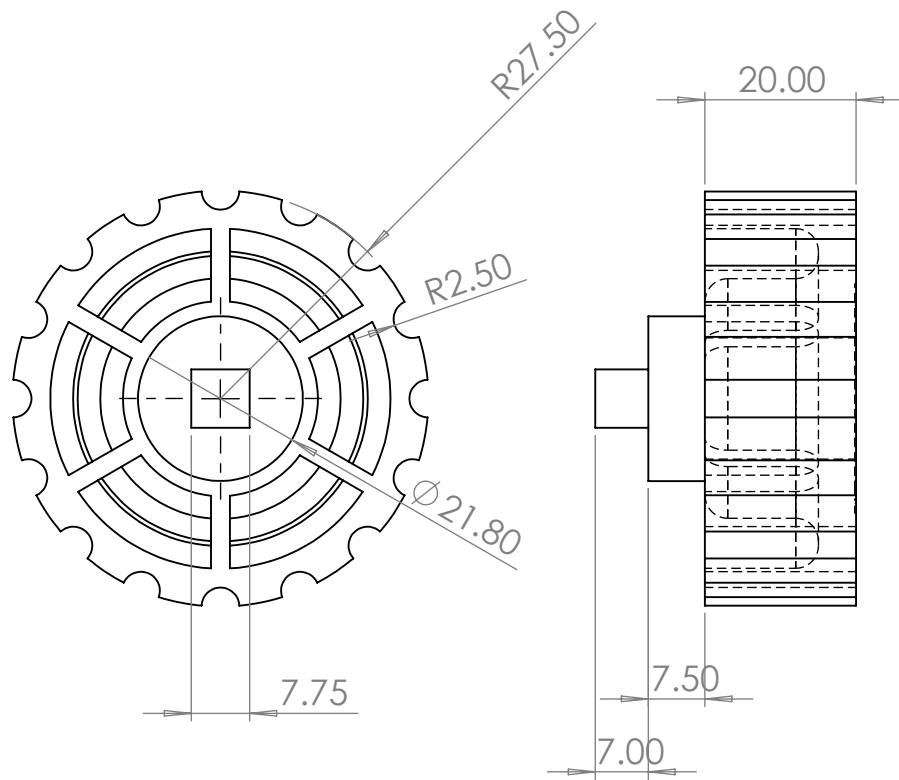

B

A

		UNLESS OTHERWISE SPECIFIED:		NAME	DATE	TITLE: DialPartTwo		
		DIMENSIONS ARE IN MILLIMETERS		DRAWN	CRR354			11/22/24
				CHECKED				
				ENG APPR.				
				MFG APPR.				
		INTERPRET GEOMETRIC TOLERANCING PER:		Q.A.			SIZE DWG. NO. REV	
		MATERIAL PCTG		COMMENTS:		A 07		
NEXT ASSY	USED ON	FINISH						
APPLICATION		DO NOT SCALE DRAWING		SCALE: 1:1		WEIGHT:	SHEET 8 OF 11	

A

PROPRIETARY AND CONFIDENTIAL
 THE INFORMATION CONTAINED IN THIS DRAWING IS THE SOLE PROPERTY OF <INSERT COMPANY NAME HERE>. ANY REPRODUCTION IN PART OR AS A WHOLE WITHOUT THE WRITTEN PERMISSION OF <INSERT COMPANY NAME HERE> IS PROHIBITED.

2

1

2

1

B

B

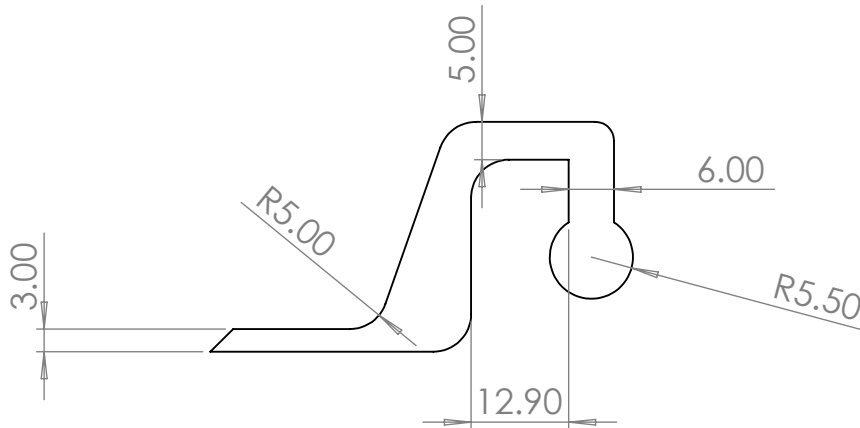
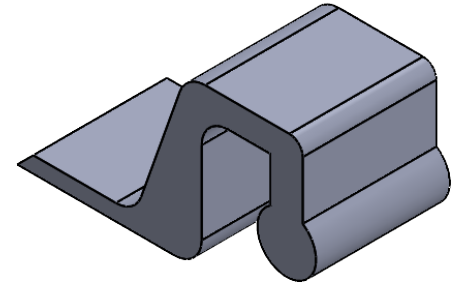
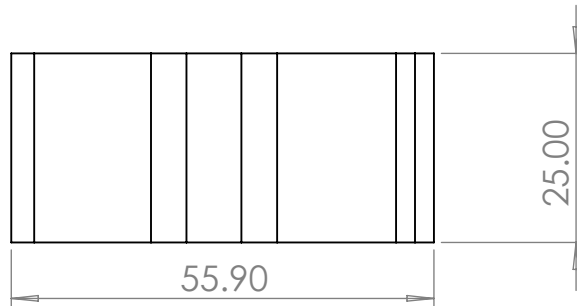

A

A

PROPRIETARY AND CONFIDENTIAL
 THE INFORMATION CONTAINED IN THIS DRAWING IS THE SOLE PROPERTY OF <INSERT COMPANY NAME HERE>. ANY REPRODUCTION IN PART OR AS A WHOLE WITHOUT THE WRITTEN PERMISSION OF <INSERT COMPANY NAME HERE> IS PROHIBITED.

		UNLESS OTHERWISE SPECIFIED:		NAME	DATE
		DIMENSIONS ARE IN MILLIMETERS	DRAWN	CRR354	11/22/24
			CHECKED		
			ENG APPR.		
			MFG APPR.		
		INTERPRET GEOMETRIC TOLERANCING PER:	Q.A.		
		MATERIAL	COMMENTS:		
		PCTG			
NEXT ASSY	USED ON	FINISH			
APPLICATION		DO NOT SCALE DRAWING			

TITLE: MouthPiece		
SIZE A	DWG. NO. 08	REV
SCALE: 1:1	WEIGHT:	SHEET 9 OF 11

2

1

B

A

B

A

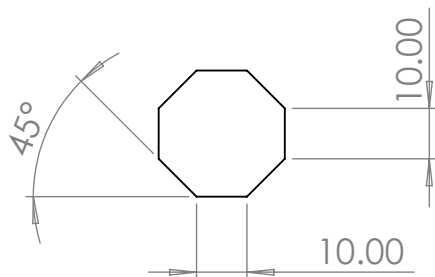
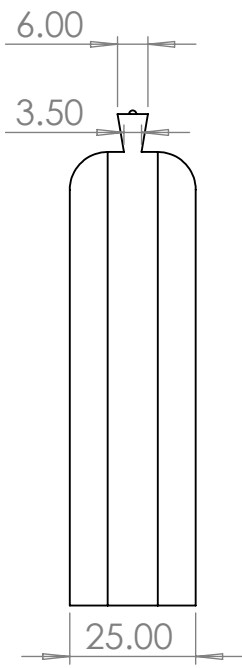
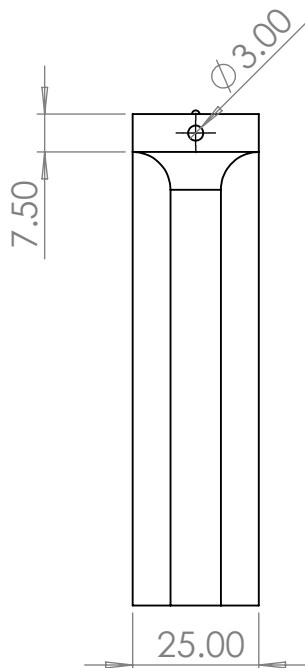

PROPRIETARY AND CONFIDENTIAL
 THE INFORMATION CONTAINED IN THIS DRAWING IS THE SOLE PROPERTY OF <INSERT COMPANY NAME HERE>. ANY REPRODUCTION IN PART OR AS A WHOLE WITHOUT THE WRITTEN PERMISSION OF <INSERT COMPANY NAME HERE> IS PROHIBITED.

		UNLESS OTHERWISE SPECIFIED:		NAME	DATE
		DIMENSIONS ARE IN MILLIMETERS	DRAWN	CRR354	11/22/24
			CHECKED		
			ENG APPR.		
			MFG APPR.		
		INTERPRET GEOMETRIC TOLERANCING PER:	Q.A.		
		MATERIAL	COMMENTS:		
		PCTG			
NEXT ASSY	USED ON	FINISH			
APPLICATION		DO NOT SCALE DRAWING			

TITLE:		
<h1>Handle</h1>		
SIZE	DWG. NO.	REV
A	09	
SCALE: 1:2	WEIGHT:	SHEET 10 OF 1

2

1

2

1

2

1

B

B

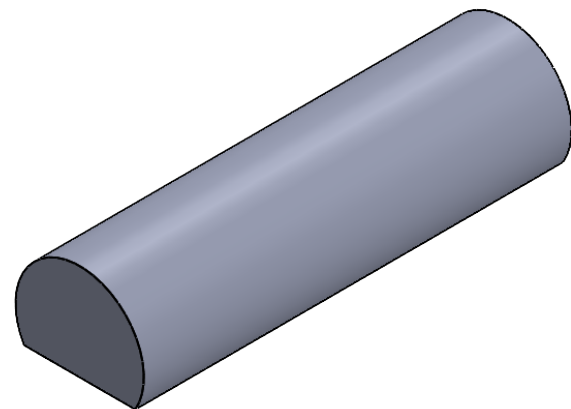
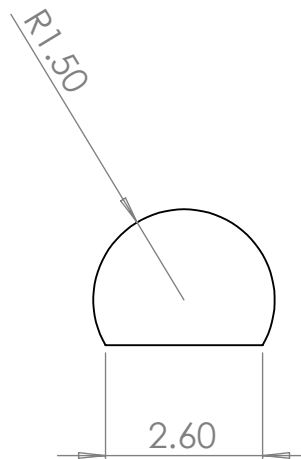
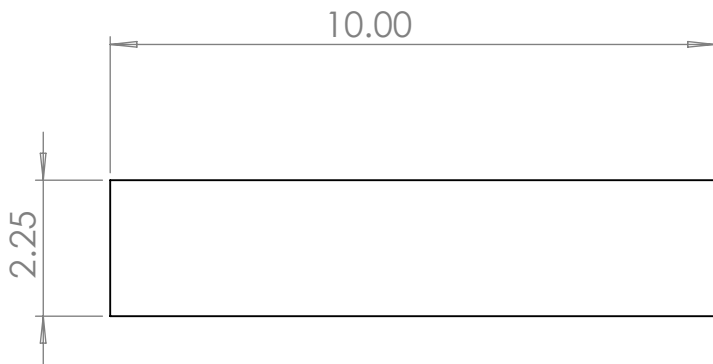

A

A

PROPRIETARY AND CONFIDENTIAL
 THE INFORMATION CONTAINED IN THIS DRAWING IS THE SOLE PROPERTY OF <INSERT COMPANY NAME HERE>. ANY REPRODUCTION IN PART OR AS A WHOLE WITHOUT THE WRITTEN PERMISSION OF <INSERT COMPANY NAME HERE> IS PROHIBITED.

		UNLESS OTHERWISE SPECIFIED:		NAME	DATE
		DIMENSIONS ARE IN MILLIMETERS	DRAWN	CRR354	11/22/24
			CHECKED		
			ENG APPR.		
			MFG APPR.		
		INTERPRET GEOMETRIC TOLERANCING PER:	Q.A.		
		MATERIAL	COMMENTS:		
		PCTG			
NEXT ASSY	USED ON	FINISH			
APPLICATION		DO NOT SCALE DRAWING			

TITLE:		
HandlePin		
SIZE	DWG. NO.	REV
A	10	
SCALE: 8:1	WEIGHT:	SHEET 11 OF 1

2

1