

ITEM NO.	PART NUMBER	DESCRIPTION	QTY.
1	Solar Shack Extrusion (15in)	Horizontal Beams	12
2	40mm Bracket	Connects Extrusion To Other Extrusion	36
3	0.25-20 in T-Nut	Slide-In Nut Allows The Extrusion To Be Fastened	152
4	1/4-20 - 1/2" Button Head Screw	For Use On Solar Shack Extrusion	104
5	0.25in Washer (0.625OD)	1/4" Washer	152
6	1/4-20 - 5/8" Button Head Screw	For Use On 4040 Extrusion (3ft)	48
7	4040 Extrusion (3ft)	Vertical Beams	4
8	Eye Bolt	Allows Test Stand To Be Secured With Support Wire	4
9	0.25-20 Nut	Threads On To Eye Bolt To Secure The Threads	4
10	Base Plate	Secures Load Cell And Distributes Load	1
11	Load Cell	Measures Created Thrust	1
12	M6x8mm Flat Head Screw	Secures Load Cell to Base Plate	3
13	Motor Holder	Holds Motor Concentricly, Options for 28mm-96mm	1
14	M2x2mm Set Screw	Secures Motor Holder to Load Cell	4
15	All Thread Brackets	Brackets To House Stabilizing Rods	4
16	1/2-13x9" All Threads	Stabilizes Motor And Keeps It Upright	4
17	Knob	Allows Easy Manipulation of Stabilizing Rods	4
18	20in Motor WITH Casing	Fule And Casing	1
19	75 mm holder	Guides The All Threads	1

PROPRIETARY AND CONFIDENTIAL
 THE INFORMATION CONTAINED IN THIS DRAWING IS THE SOLE PROPERTY OF <INSERT COMPANY NAME HERE>. ANY REPRODUCTION IN PART OR AS A WHOLE WITHOUT THE WRITTEN PERMISSION OF <INSERT COMPANY NAME HERE> IS PROHIBITED.

UNLESS OTHERWISE SPECIFIED:		NAME	DATE	TITLE: Test Stand Assembly
DIMENSIONS ARE IN MILLIMETERS TOLERANCES: See Part Drawings FRACTIONAL<MOD-PM> ANGULAR: MACH<MOD-PM> TWO PLACE DECIMAL THREE PLACE DECIMAL		DRAWN	RLD 11/1/23	
INTERPRET GEOMETRIC TOLERANCING PER:		CHECKED	GAM 4/13/24	
MATERIAL		ENG APPR.		
FINISH		MFG APPR.		SIZE DWG. NO. REV B
NEXT ASSY	USED ON	Q.A.		
APPLICATION		COMMENTS: All Parts Listed Besides Support Cable And Stakes. Part 12 Hidden Under Base Plate		SCALE: 1:5 WEIGHT: SHEET 1 OF 1

8 7 6 5 4 3 2 1

F

F

E

E

D

D

C

C

B

B

A

A

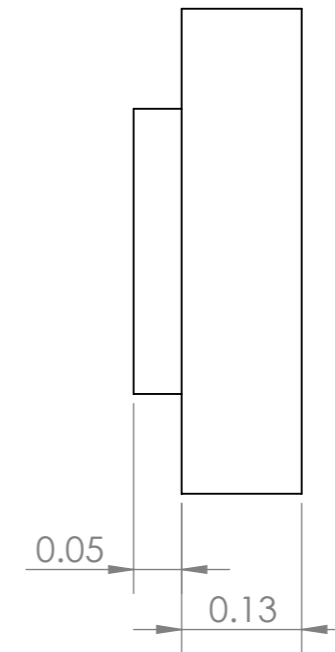
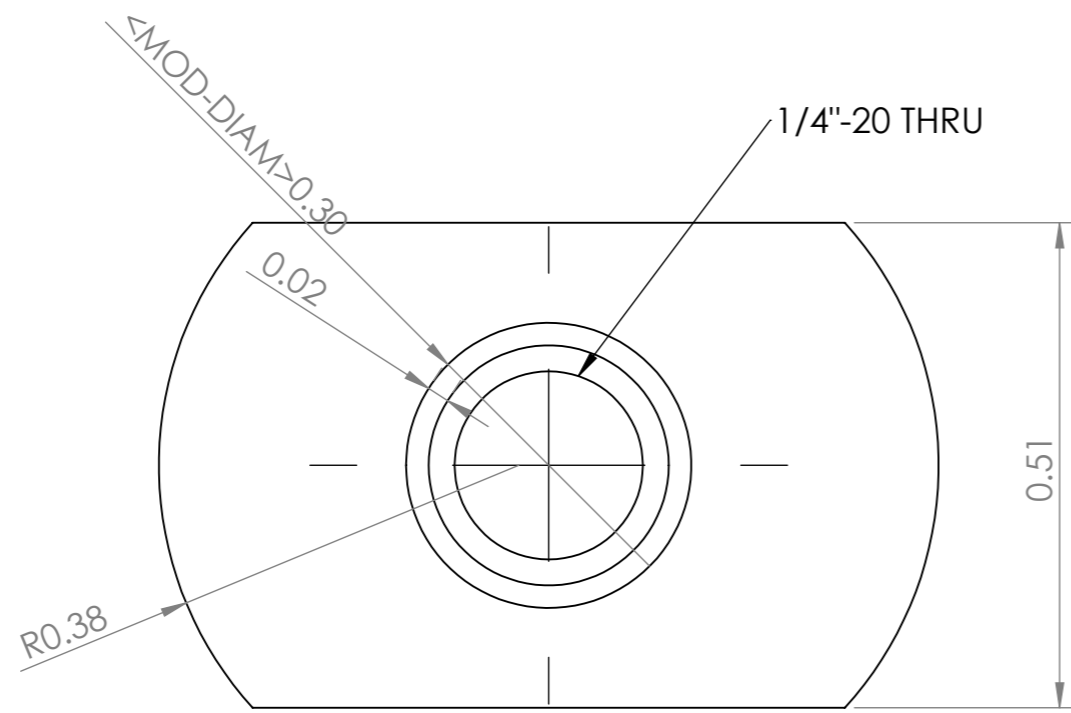
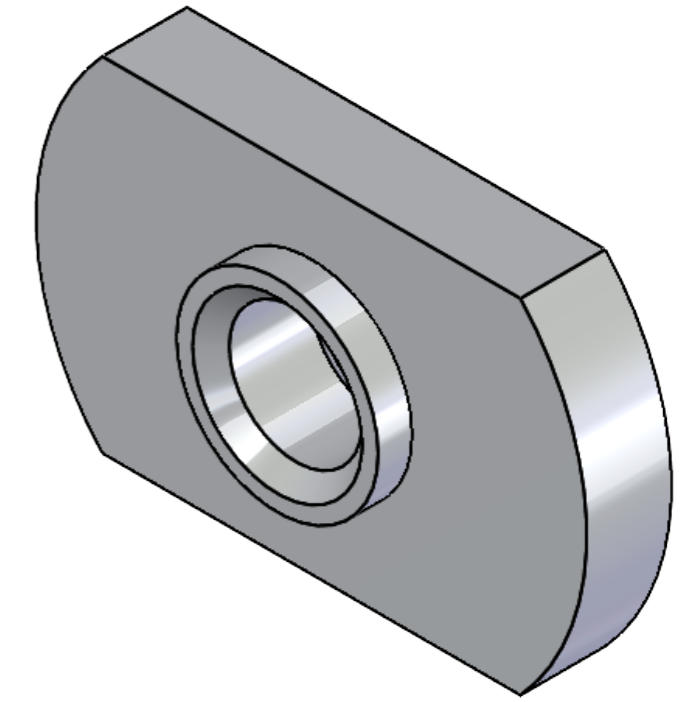

UNLESS OTHERWISE SPECIFIED: DIMENSIONS ARE IN MILLIMETERS SURFACE FINISH: TOLERANCES: As Purchased LINEAR: ANGULAR:				FINISH:		DEBURR AND BREAK SHARP EDGES		DO NOT SCALE DRAWING		REVISION		
DRAWN	NAME	SIGNATURE	DATE					TITLE: 0.25-20 in T-Nut				
CHK'D	RLD		12/1/23					DWG NO.				A3
APPV'D								SCALE: 5:1				SHEET 1 OF 1
MFG								WEIGHT:				
Q.A												

8 7 6 5 4 3 2 1

B

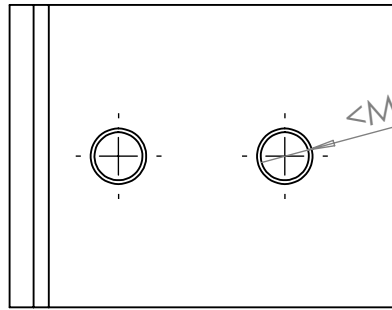

2

1

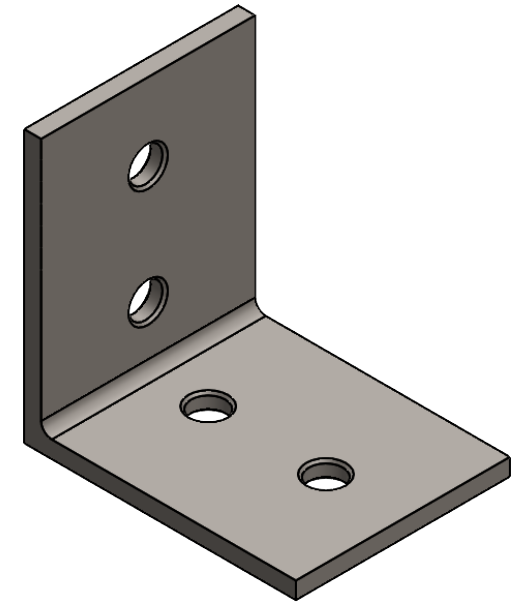

B

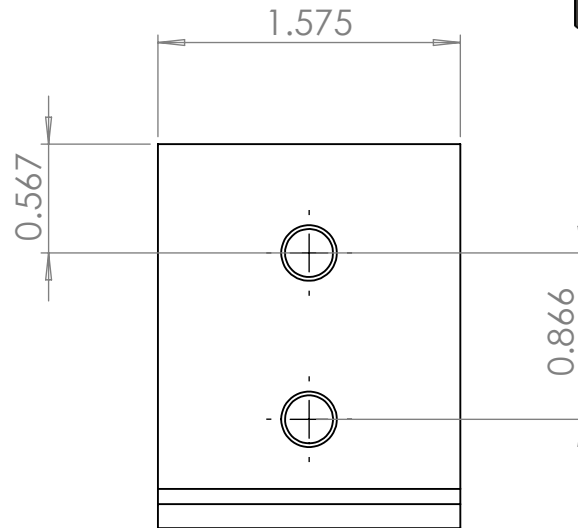
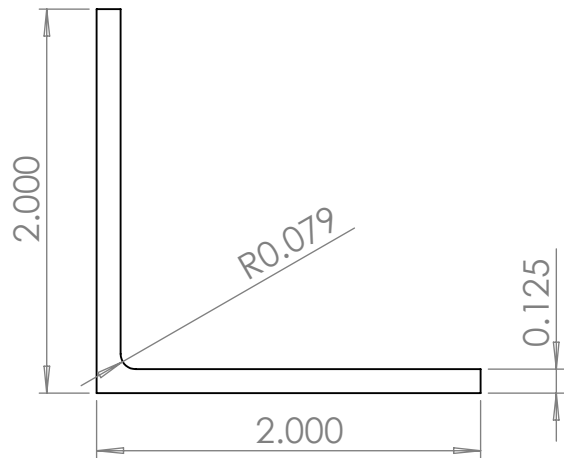

A

A

PROPRIETARY AND CONFIDENTIAL
 THE INFORMATION CONTAINED IN THIS DRAWING IS THE SOLE PROPERTY OF <INSERT COMPANY NAME HERE>. ANY REPRODUCTION IN PART OR AS A WHOLE WITHOUT THE WRITTEN PERMISSION OF <INSERT COMPANY NAME HERE> IS PROHIBITED.

		UNLESS OTHERWISE SPECIFIED:		NAME	DATE
		DIMENSIONS ARE IN INCHES	DRAWN	RLD	12/1/23
		TOLERANCES: +/- 0.01	CHECKED		
		FRACTIONAL <MOD-PM>	ENGINE APPR.		
		ANGULAR: MACH <MOD-PM>	MFG APPR.		
		TWO PLACE DECIMAL <MOD-PM>			
		THREE PLACE DECIMAL <MOD-PM>			
		INTERPRET GEOMETRIC TOLERANCING PER:	Q.A.		
		MATERIAL:	COMMENTS:		
		Steel			
NEXT ASSY	USED ON	FINISH			
APPLICATION		DO NOT SCALE DRAWING			

TITLE:

40mm Bracket

SIZE
A

DWG. NO.

REV

SCALE: 1:1

WEIGHT:

SHEET 1 OF 1

2

1

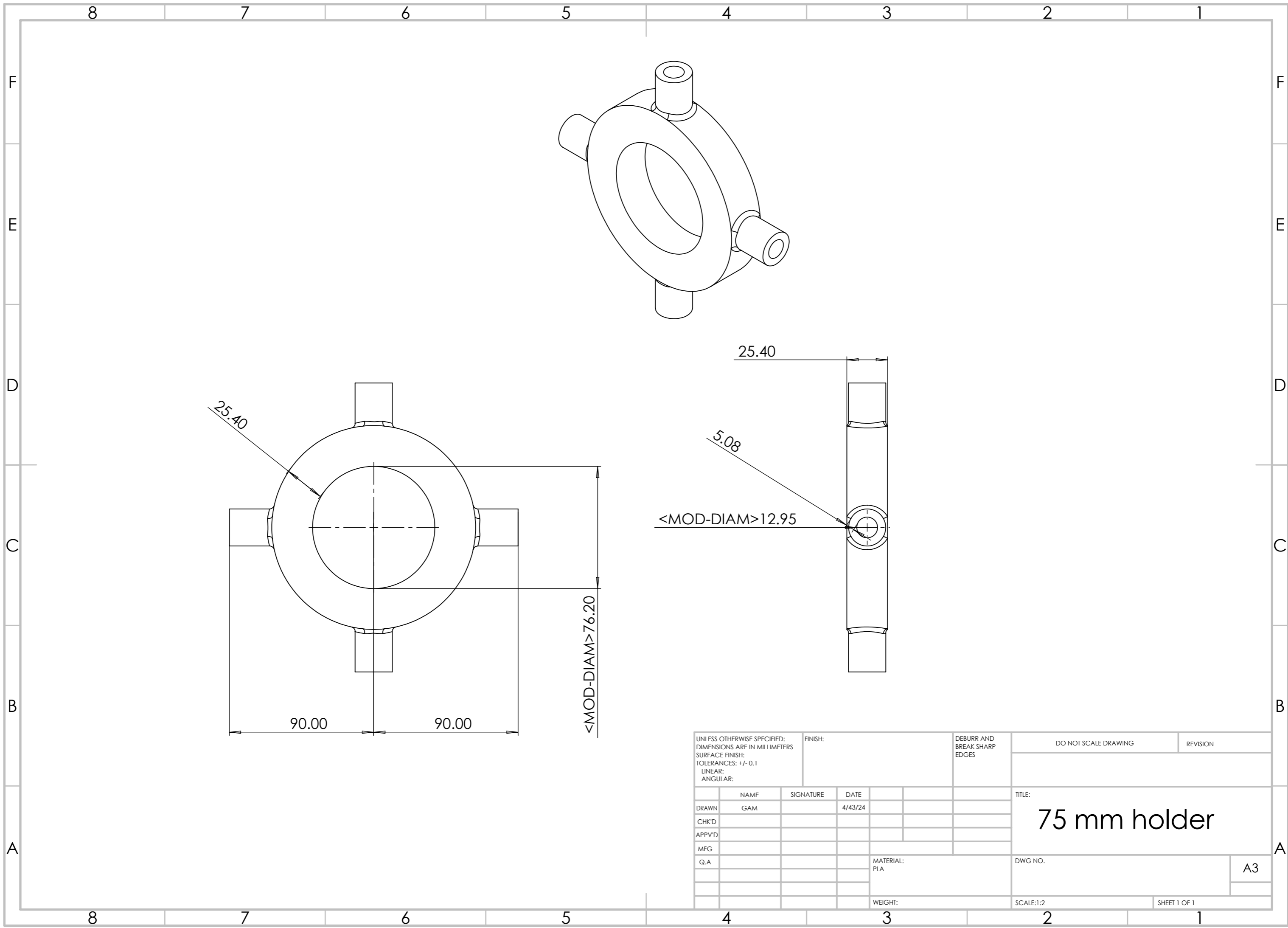

UNLESS OTHERWISE SPECIFIED: DIMENSIONS ARE IN MILLIMETERS SURFACE FINISH: TOLERANCES: +/- 0.1 LINEAR: ANGULAR:				FINISH:		DEBURR AND BREAK SHARP EDGES		DO NOT SCALE DRAWING		REVISION					
								TITLE: 75 mm holder							
DRAWN				NAME		SIGNATURE						DATE			
CHK'D															
APPV'D															
MFG															
Q.A								MATERIAL: PLA		DWG NO.					
								WEIGHT:		SCALE:1:2					
										SHEET 1 OF 1					
										A3					

8 7 6 5 4 3 2 1

F

F

E

E

D

D

C

C

B

B

A

A

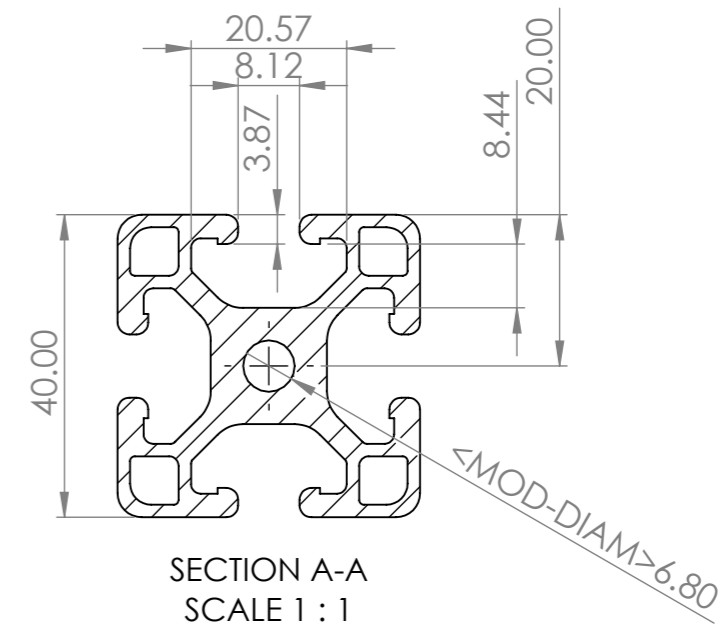
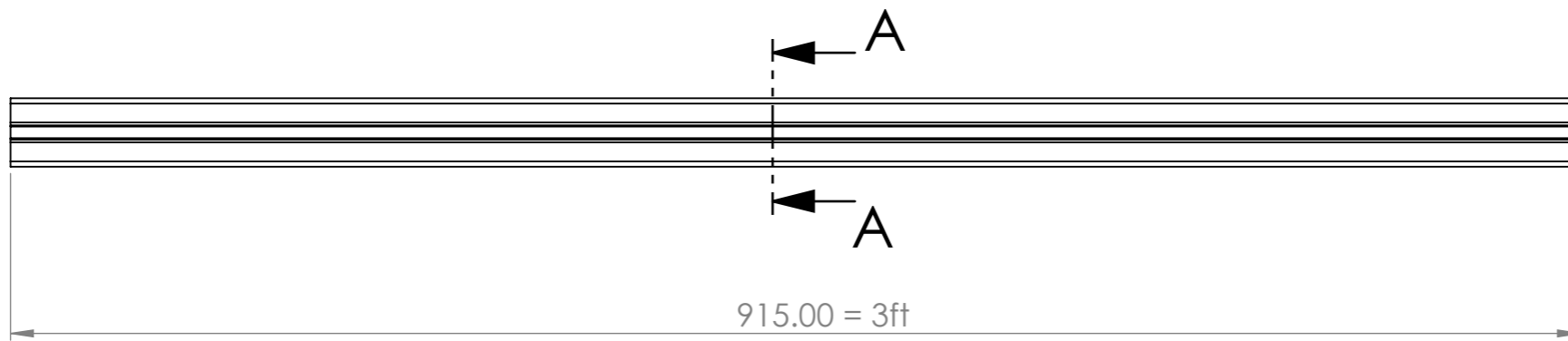
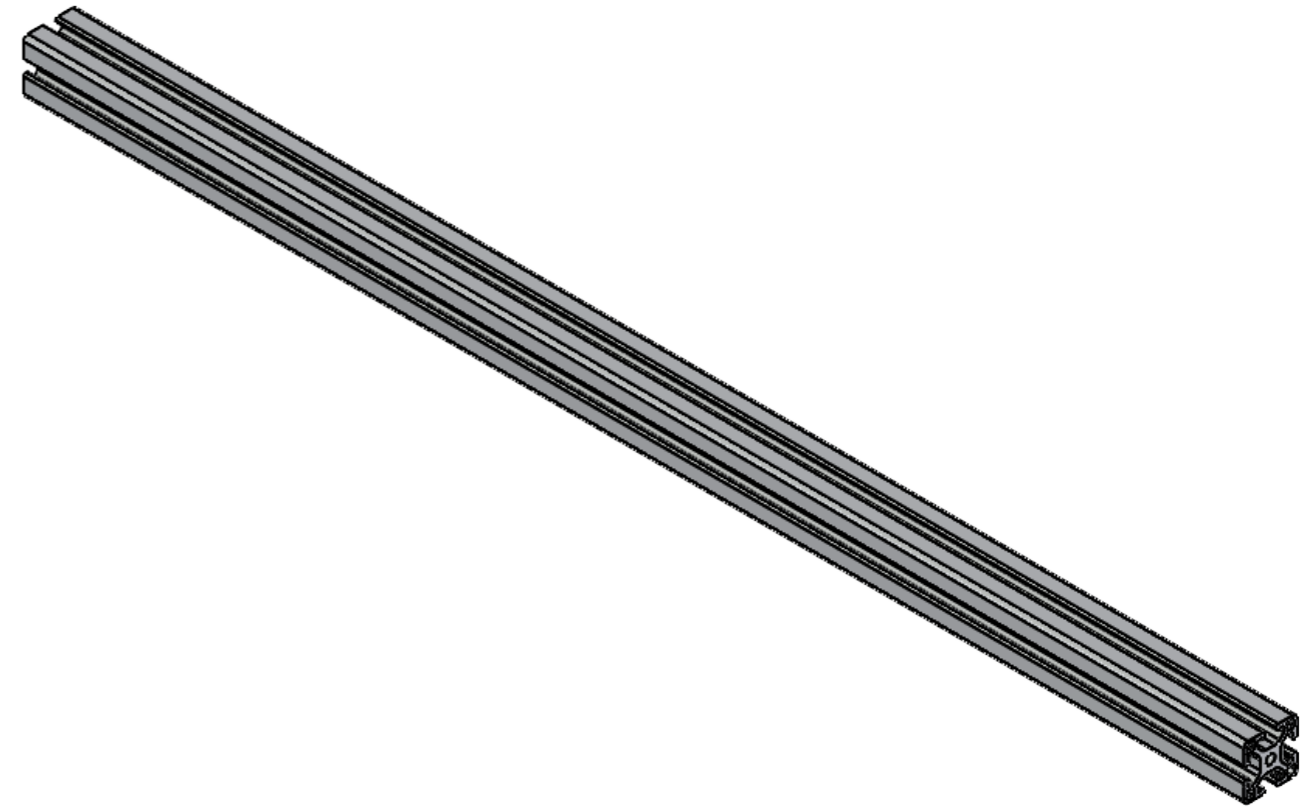

UNLESS OTHERWISE SPECIFIED: DIMENSIONS ARE IN MILLIMETERS SURFACE FINISH: TOLERANCES: +/- 1 LINEAR: ANGULAR:				FINISH:		DEBURR AND BREAK SHARP EDGES		DO NOT SCALE DRAWING		REVISION	
DRAWN				NAME		SIGNATURE		DATE		TITLE:	
CHK'D				RLD				12/1/23		4040 Extrusion (3ft)	
APPV'D											
MFG											
Q.A										MATERIAL: Aluminum	
										DWG NO.	
										A3	
										SCALE: 1:4	
										SHEET 1 OF 1	

8 7 6 5 4 3 2 1

B

B

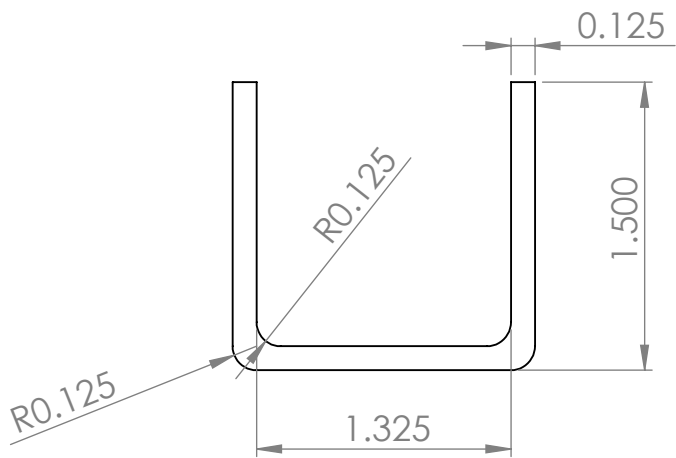
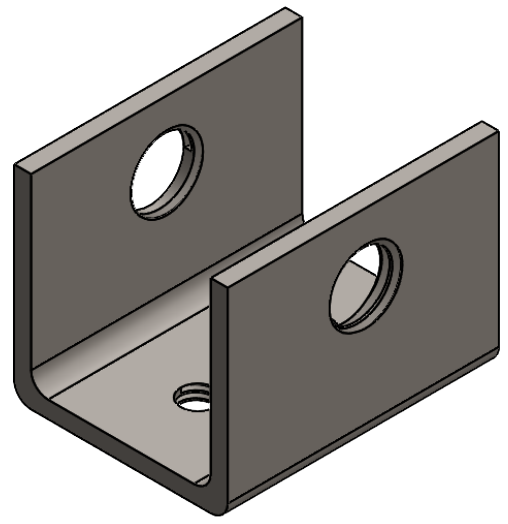
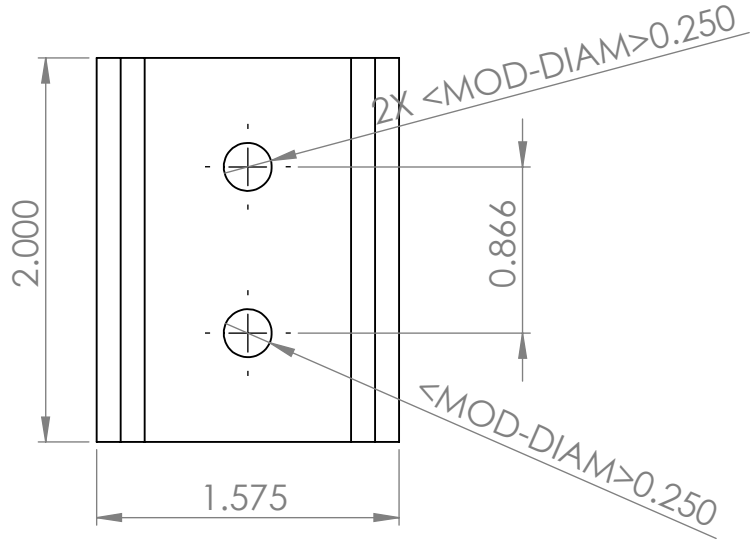

<MOD-DIAM>0.500
Drill For 1/2-13 Threads

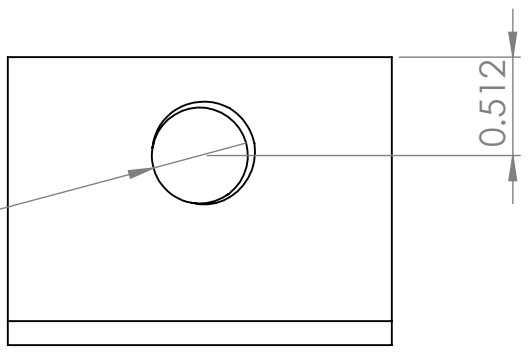

A

A

PROPRIETARY AND CONFIDENTIAL
THE INFORMATION CONTAINED IN THIS DRAWING IS THE SOLE PROPERTY OF <INSERT COMPANY NAME HERE>. ANY REPRODUCTION IN PART OR AS A WHOLE WITHOUT THE WRITTEN PERMISSION OF <INSERT COMPANY NAME HERE> IS PROHIBITED.

		UNLESS OTHERWISE SPECIFIED:		NAME	DATE
		DIMENSIONS ARE IN INCHES	DRAWN	RLD	12/1/23
		TOLERANCES: +/- 0.001	CHECKED		
		FRACTIONAL <MOD-PM>	ENG APPR.		
		ANGULAR: MACH <MOD-PM>	MFG APPR.		
		TWO PLACE DECIMAL <MOD-PM>	Q.A.		
		THREE PLACE DECIMAL <MOD-PM>	COMMENTS:		
		INTERPRET GEOMETRIC TOLERANCING PER:			
		MATERIAL: Steel			
NEXT ASSY	USED ON	FINISH			
APPLICATION		DO NOT SCALE DRAWING			

TITLE: All Thread Brackets		
SIZE A	DWG. NO.	REV
SCALE: 1:1	WEIGHT:	SHEET 1 OF 1

2

1

8 7 6 5 4 3 2 1

F

F

E

E

D

D

C

C

B

B

A

A

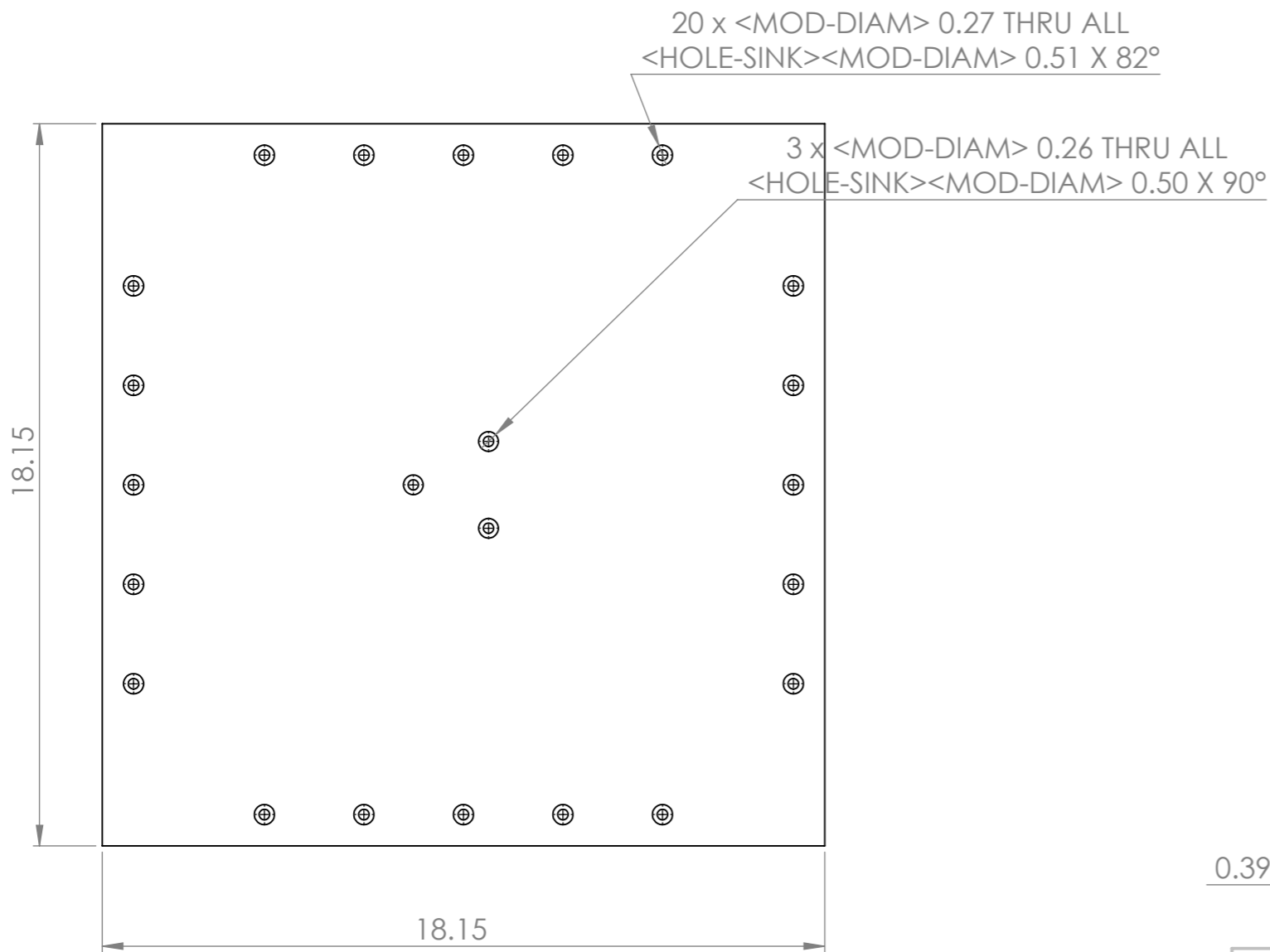
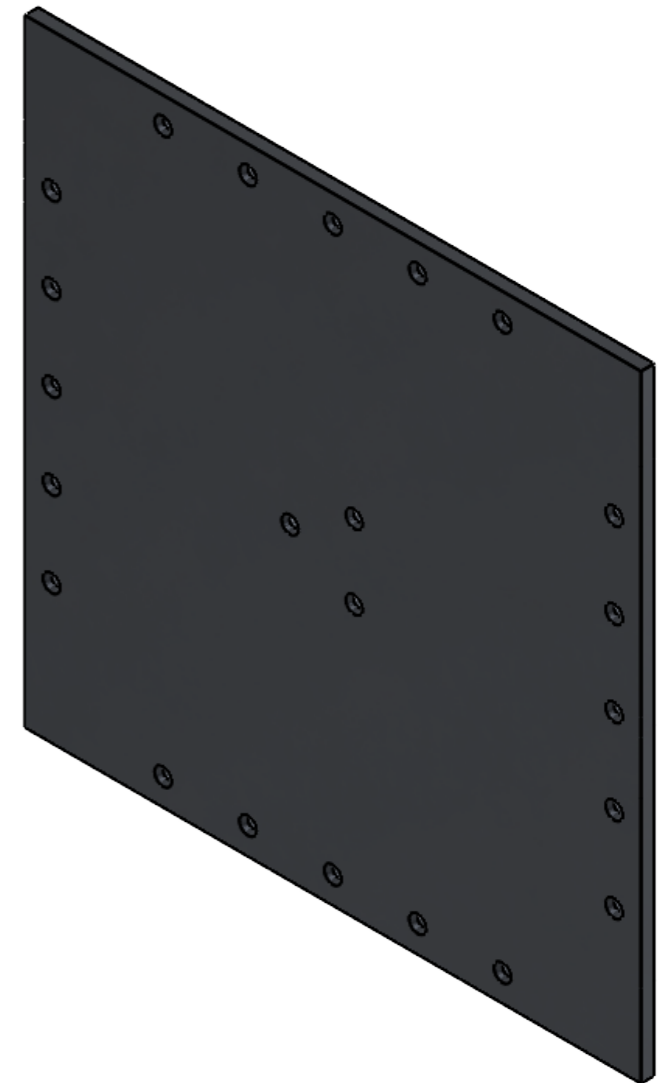

UNLESS OTHERWISE SPECIFIED: DIMENSIONS ARE IN MILLIMETERS SURFACE FINISH: TOLERANCES: +/- 0.001 LINEAR: ANGULAR:				FINISH:		DEBURR AND BREAK SHARP EDGES		DO NOT SCALE DRAWING		REVISION	
								TITLE: <h1 style="text-align: center;">Base Plate</h1>			
								DWG NO.		A3	
								SCALE: 1:4		SHEET 1 OF 1	

8 7 6 5 4 3 2 1

8 7 6 5 4 3 2 1

F

F

E

E

D

D

C

C

B

B

A

A

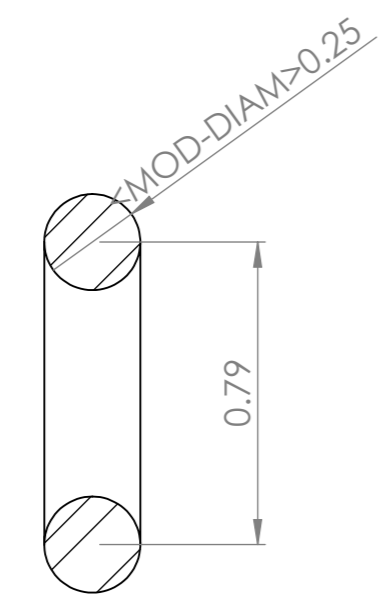
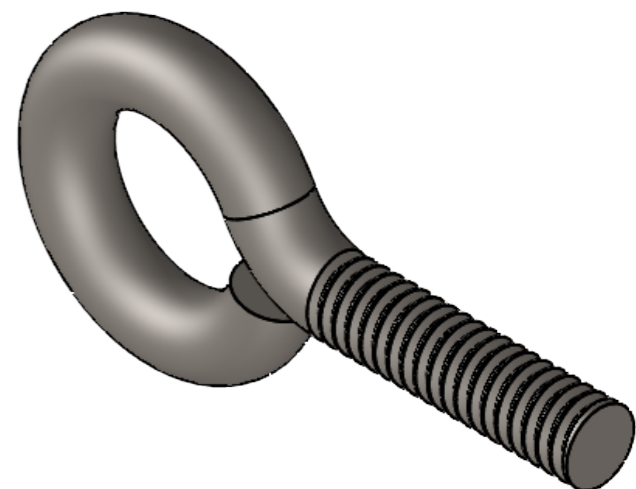

SECTION B-B

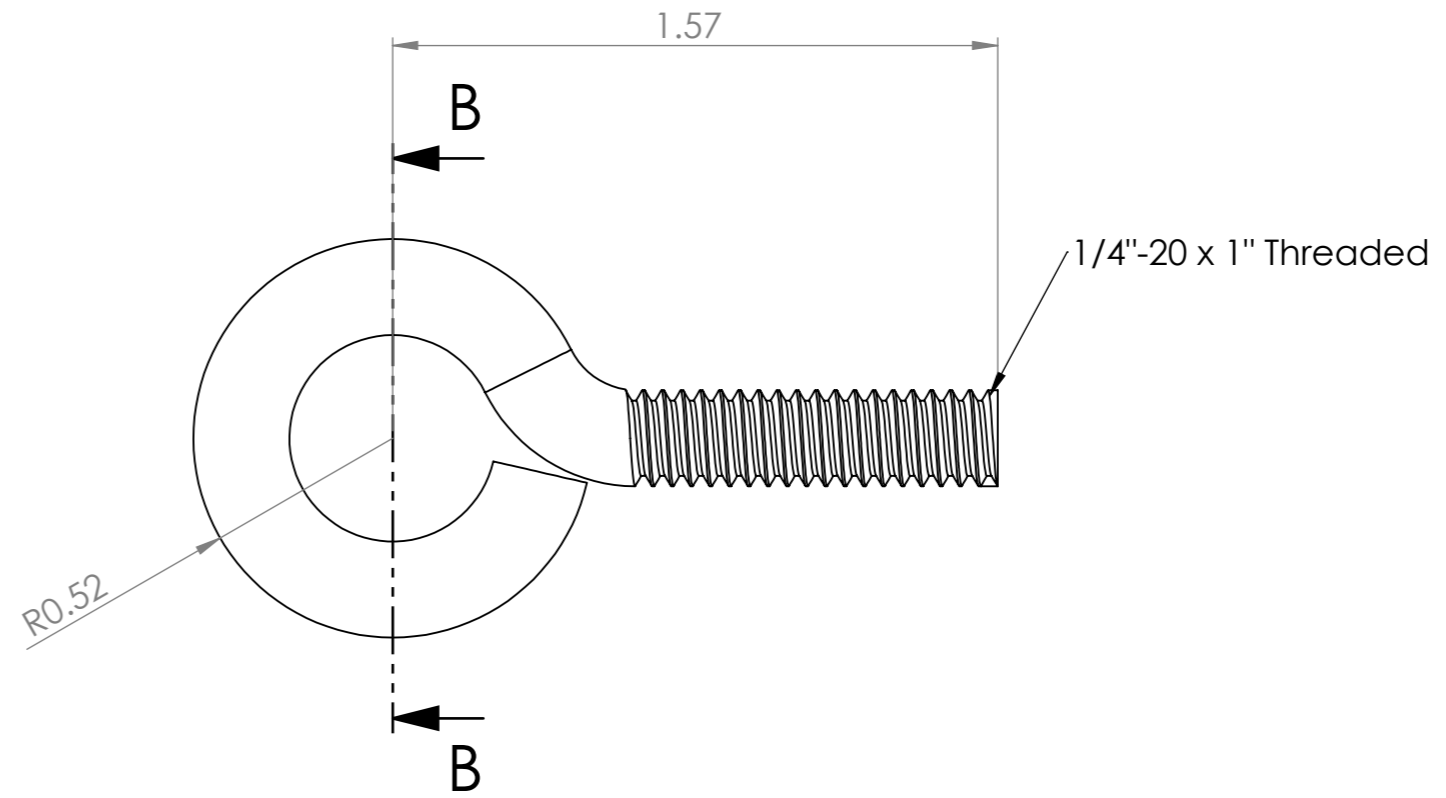

UNLESS OTHERWISE SPECIFIED: DIMENSIONS ARE IN MILLIMETERS SURFACE FINISH: TOLERANCES: As Purchased LINEAR: ANGULAR:				FINISH:		DEBURR AND BREAK SHARP EDGES		DO NOT SCALE DRAWING		REVISION	
DRAWN				NAME		SIGNATURE		DATE		TITLE:	
CHK'D				RLD				12/1/23		Eye Bolt	
APPV'D											
MFG											
Q.A											
								MATERIAL:		DWG NO.	
										A3	
								WEIGHT:		SCALE:2:1	
										SHEET 1 OF 1	

8 7 6 5 4 3 2 1

8 7 6 5 4 3 2 1

F

F

E

E

D

D

C

C

B

B

A

A

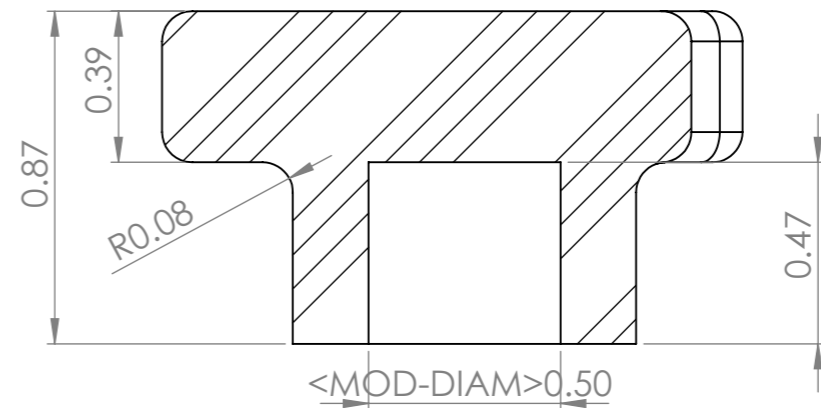
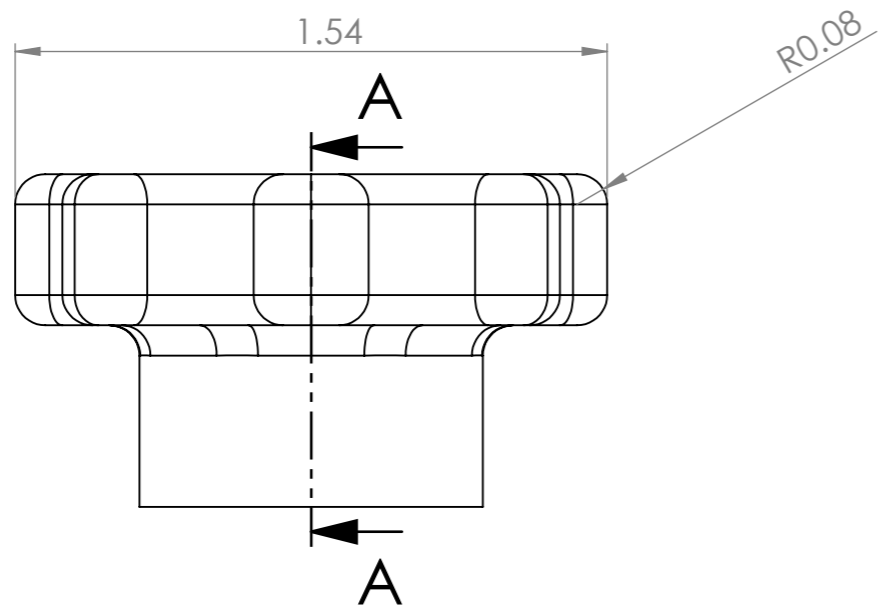
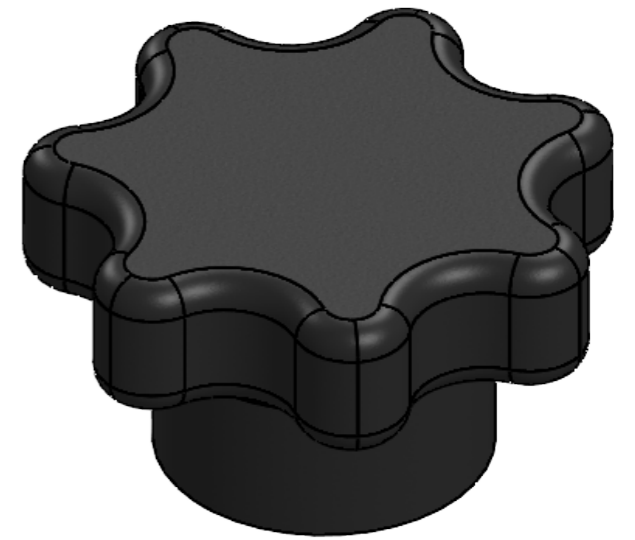
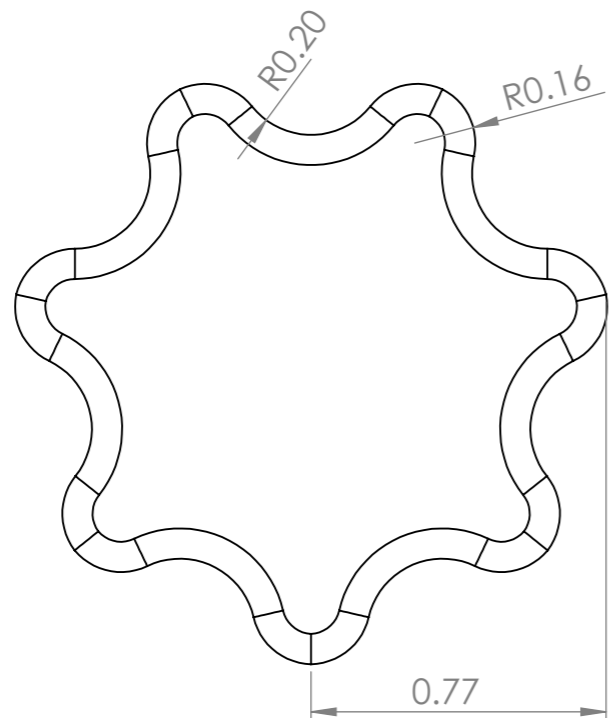

SECTION A-A

UNLESS OTHERWISE SPECIFIED: DIMENSIONS ARE IN MILLIMETERS SURFACE FINISH: TOLERANCES: + 0.01 LINEAR: ANGULAR:				FINISH:		DEBURR AND BREAK SHARP EDGES		DO NOT SCALE DRAWING		REVISION		
								TITLE: All-Thread Knob				
DRAWN RLD				SIGNATURE		DATE 12/1/23		DWG NO.				A3
CHK'D								SCALE:2:1				SHEET 1 OF 1
APPV'D								MATERIAL: PLA				
MFG								WEIGHT:				
Q.A												

8 7 6 5 4 3 2 1

8 7 6 5 4 3 2 1

F

F

E

E

D

D

C

C

B

B

A

A

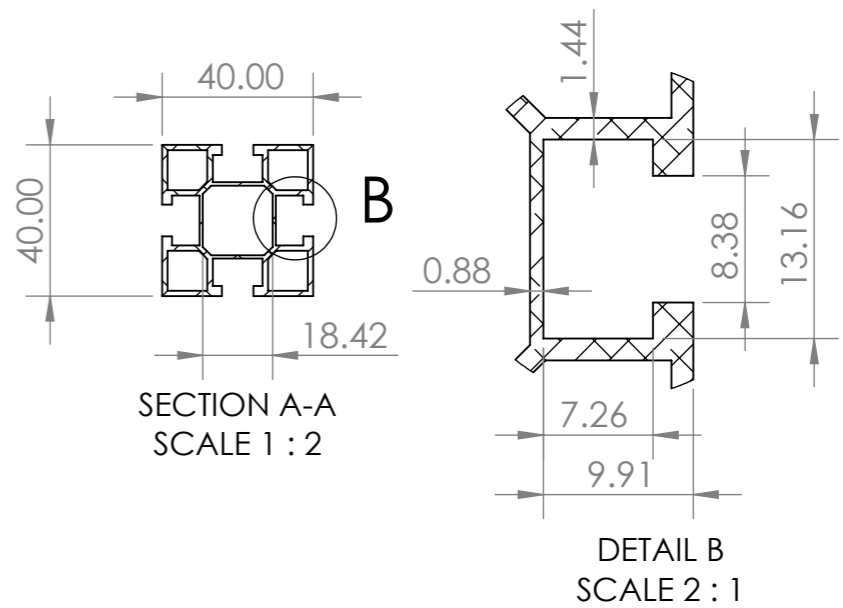
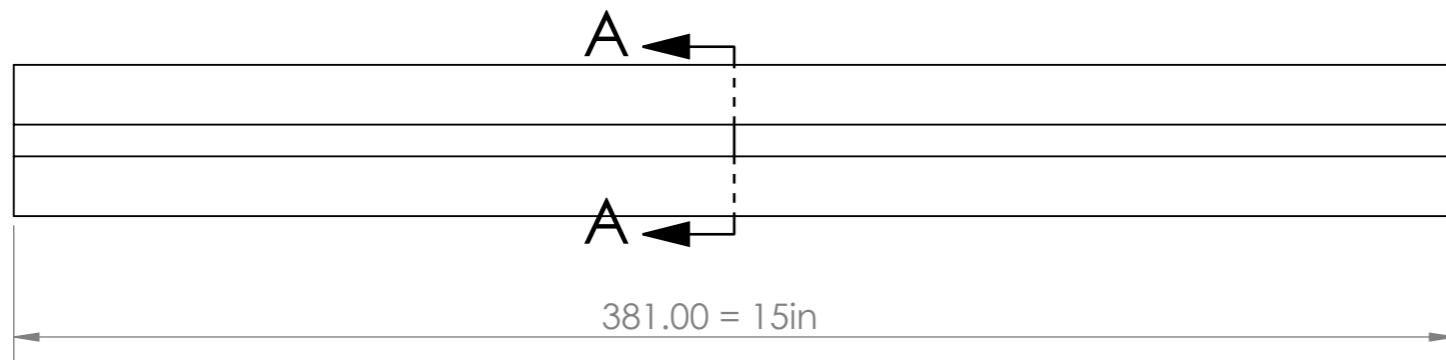
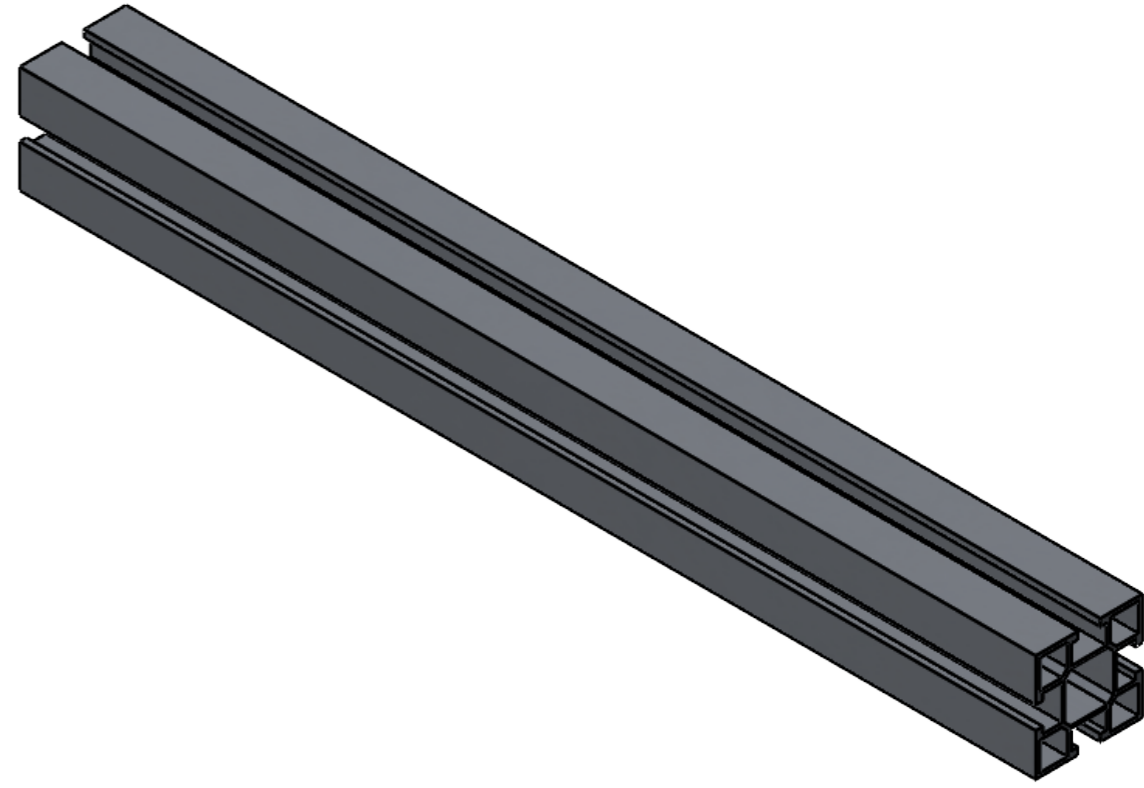

UNLESS OTHERWISE SPECIFIED: DIMENSIONS ARE IN MILLIMETERS SURFACE FINISH: TOLERANCES: +/- 0.1 in LINEAR: ANGULAR:				FINISH:		DEBURR AND BREAK SHARP EDGES		DO NOT SCALE DRAWING		REVISION	
DRAWN				NAME		SIGNATURE		DATE		TITLE:	
CHK'D				RLD				12/1/23		Solar Shack Extrusion (15in)	
APPV'D											
MFG											
Q.A											
								MATERIAL: Aluminum		DWG NO.	
								WEIGHT:		SCALE: 1:2	
										SHEET 1 OF 1	

8 7 6 5 4 3 2 1