

SECTION A-A
SCALE 1 : 3

ITEM NO.	PART NUMBER	DESCRIPTION	QTY.
1	Pressure Vessel	Where the burn is conducted, must be able to withstand high pressures	1
2	Strand Landing Platform	Where the test strand is connected to the support wire	1
3	Strand	Small 3inx0.25in cast of propellant meant to burn inside the vessel	1
4	Strand Support Wire	Attached to 3/4in NPT plug to be able to be taken out of vessel	1
5	3/4in NPT Pipe Cross	Expands number of connection points to vessel	1
6	3/4in NPT Plug with 1/4in Counterbore	Attaches strand support wire to plug to be able to get strand out of vessel	1
7	3/4in NPT Plug with 1/4in NPT Thru Hole	For Pressure Transducer and Pressure Relief Valve to connect to vessel	2
8	Pressure Transducer	Measures internal pressure of vessel when strand is burned	1
9	3/4in NPT Pipe Nipple	Attaches two female NPT threads, from the cross to the vessel	1
10	Pressure Relief Valve	Pressure release valve to expell excess vessel pressure	1
11	2in NPT Plug with 1/2in NPT Thru Hole	Connects thermocouple to vessel with connection ring	1
12	Threaded (1/2in NPT) K-Type Thermocouple	Measures internal temperature of vessel when strand is burned	1
13	2in NPT Threaded Connection Ring	Welded to bottom of vessel which gives appropriate thread count for 2in Plug	1

UNLESS OTHERWISE SPECIFIED: DIMENSIONS ARE IN MILLIMETERS		FINISH:		DEBURR AND BREAK SHARP EDGES		DO NOT SCALE DRAWING		REVISION	
SURFACE FINISH:									
TOLERANCES:									
LINEAR:									
ANGULAR:									
NAME	SIGNATURE	DATE				TITLE: Strand Burner			
DRAWN RLD <3		11/30/23							
CHK'D									
APPV'D									
MFG									
Q.A					MATERIAL:	DWG NO.		A3	
					WEIGHT:	SCALE: 1:3		SHEET 1 OF 1	

8 7 6 5 4 3 2 1

F

F

E

E

D

D

C

C

B

B

A

A

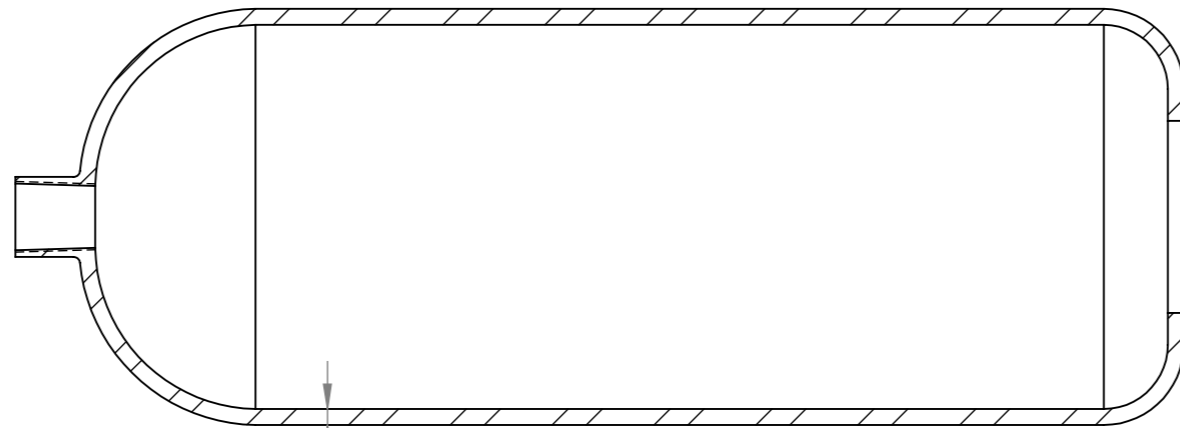
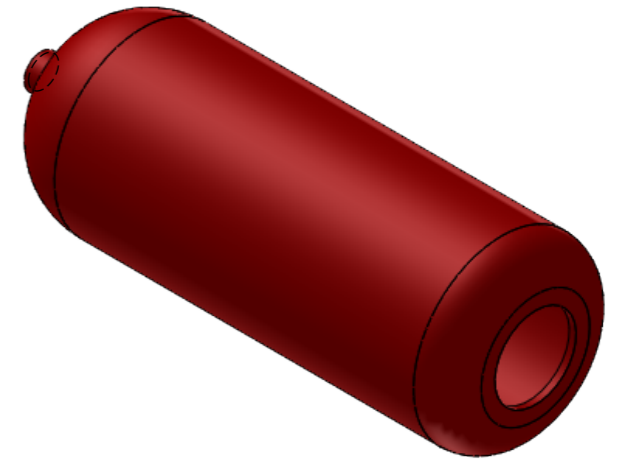

SECTION A-A
SCALE 1 : 3

3/4 NPT Tapped Hole

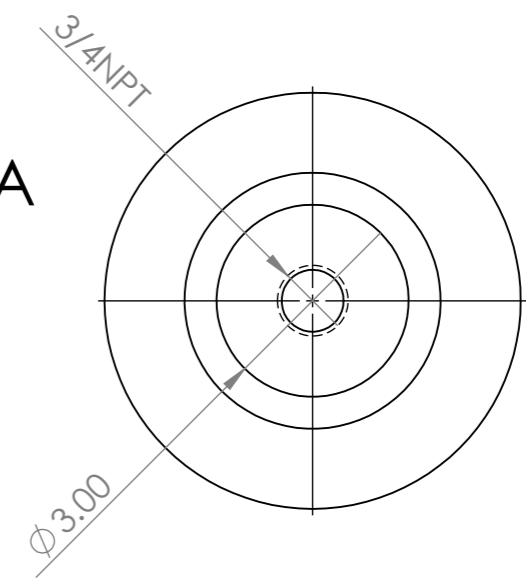
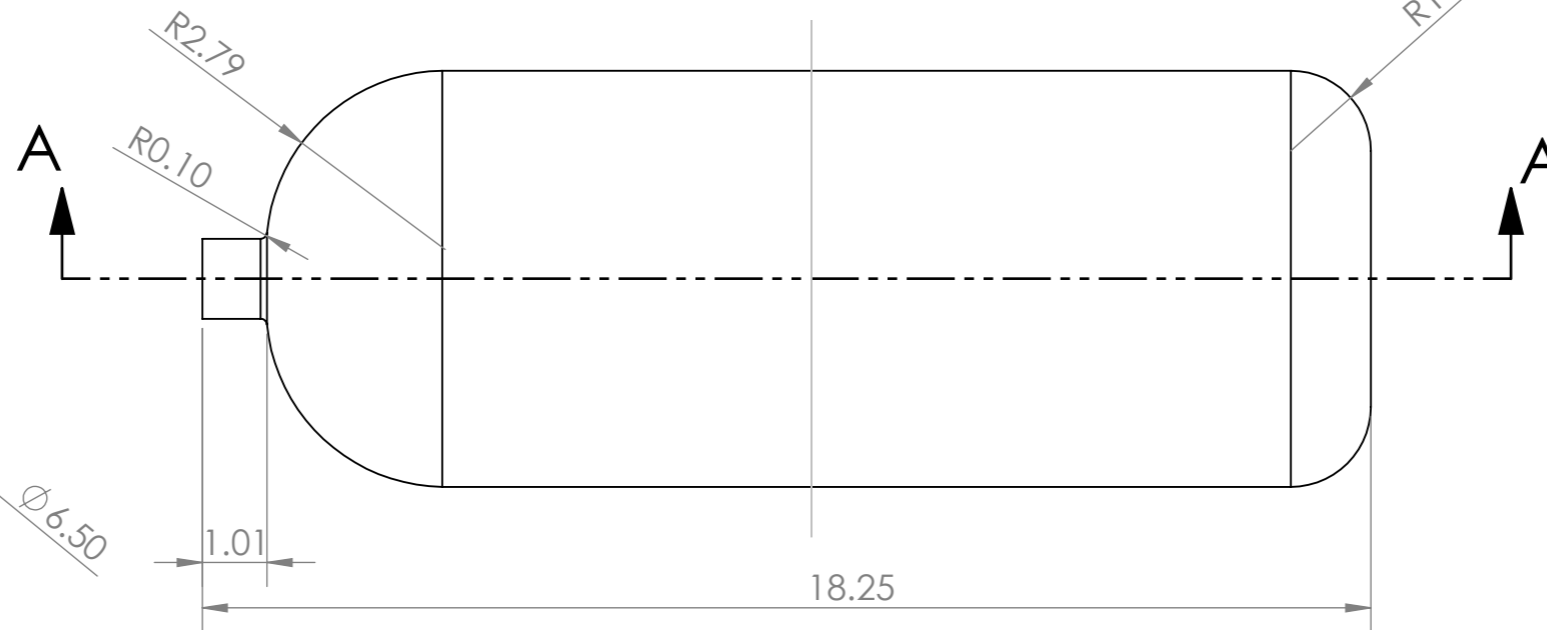
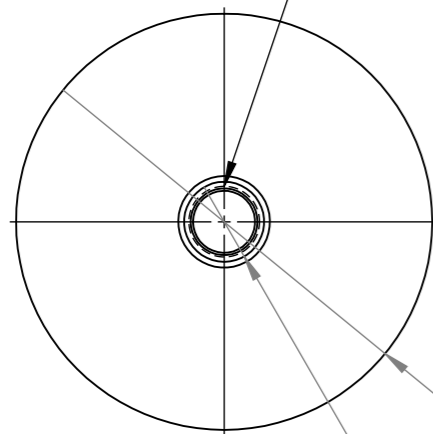

UNLESS OTHERWISE SPECIFIED: DIMENSIONS ARE IN MILLIMETERS SURFACE FINISH: TOLERANCES: LINEAR: ANGULAR:				FINISH:		DEBURR AND BREAK SHARP EDGES		DO NOT SCALE DRAWING		REVISION	
DRAWN RLD				SIGNATURE		DATE 12/1/23		TITLE: Pressure Vessel is conducting must be able to withstand high pressures			
CHK'D				APPV'D		MFG		DWG NO.		A3	
Q.A				MATERIAL:		WEIGHT:		SCALE: 1:3		SHEET 1 OF 1	

8 7 6 5 4 3 2 1

F
E
D
C
B
A

F
E
D
C
B
A

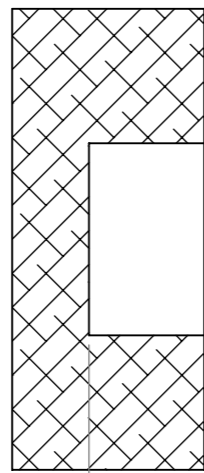

SECTION A-A

0.15

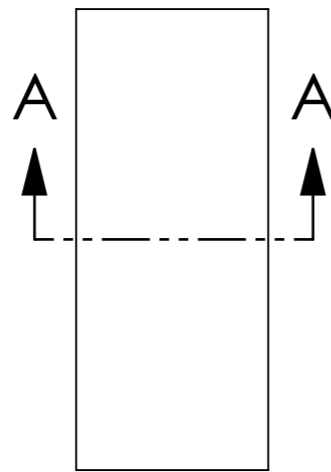

0.25

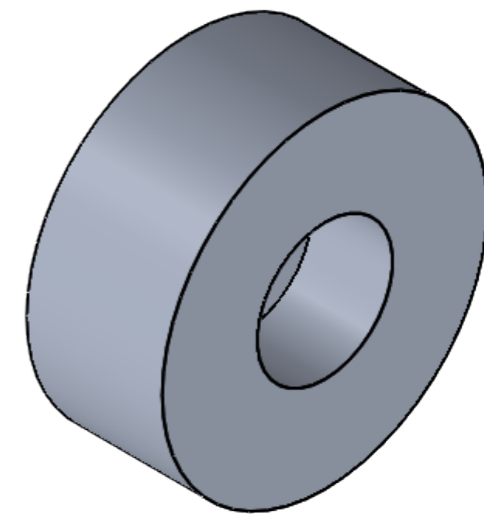
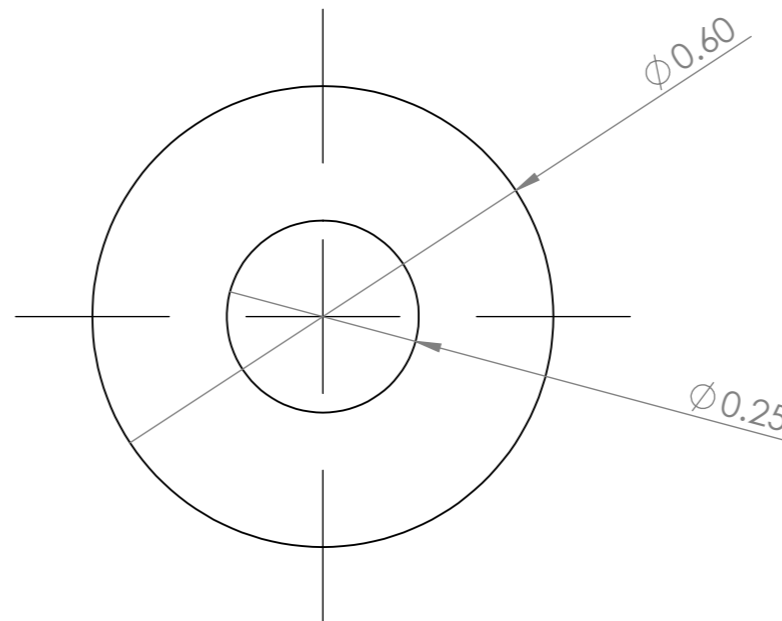

UNLESS OTHERWISE SPECIFIED: DIMENSIONS ARE IN MILLIMETERS SURFACE FINISH: TOLERANCES: LINEAR: ANGULAR:				FINISH:		DEBURR AND BREAK SHARP EDGES		DO NOT SCALE DRAWING		REVISION	
								TITLE: Wire thread fastener Plastic connected to the support wire			
DRAWN		NAME		SIGNATURE		DATE		MATERIAL:		SCALE:4:1	
CHK'D		RLD				12/1/23				SHEET 1 OF 1	
APPV'D											
MFG											
Q.A											
								WEIGHT:			

8 7 6 5 4 3 2 1

F
E
D
C
B
A

F
E
D
C
B
A

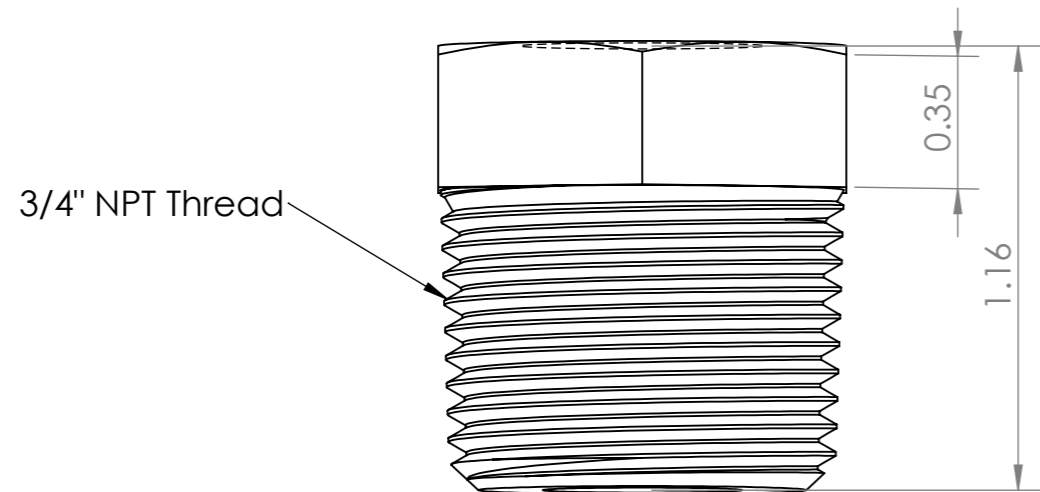
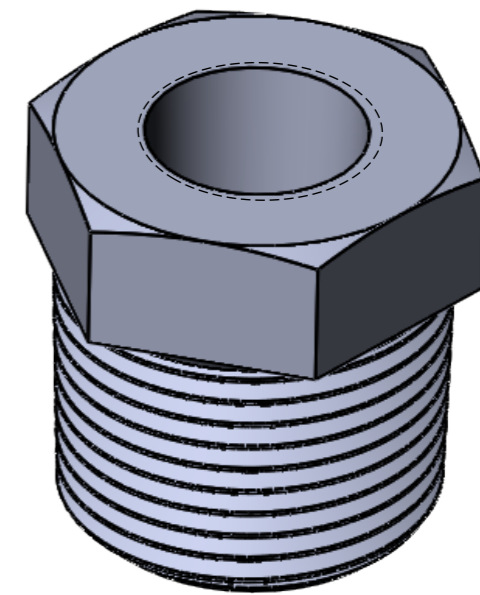
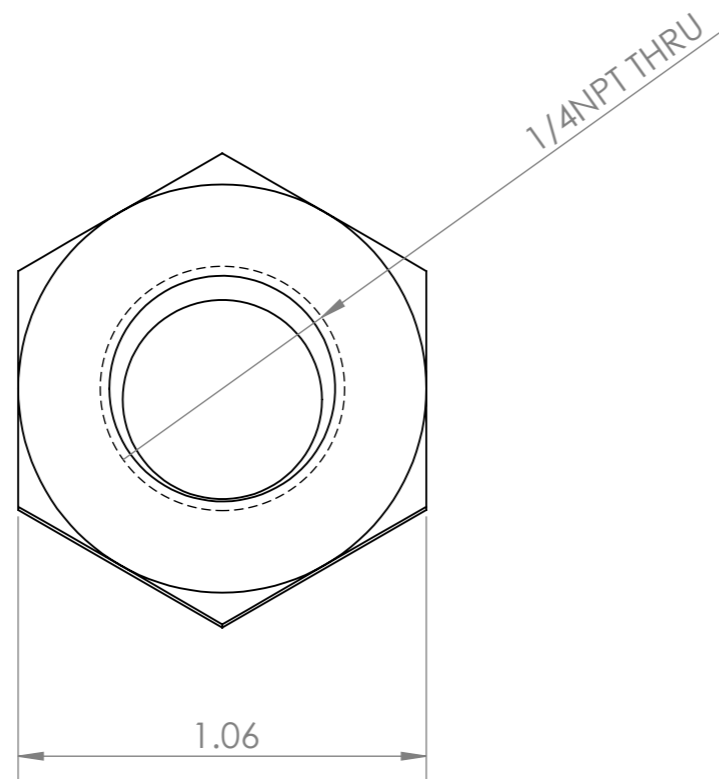

UNLESS OTHERWISE SPECIFIED: DIMENSIONS ARE IN MILLIMETERS SURFACE FINISH: TOLERANCES: LINEAR: ANGULAR:			FINISH:		DEBURR AND BREAK SHARP EDGES		DO NOT SCALE DRAWING		REVISION		
DRAWN			NAME		SIGNATURE		DATE		TITLE:		
CHK'D			RLD				12/1/23		0.75" NPT Plug With 1/4" NPT Thru Hole		
APPV'D									DWG NO.		
MFG									A3		
Q.A							MATERIAL:		Steel		
							WEIGHT:		SCALE:2:1		
									SHEET 1 OF 1		

8 7 6 5 4 3 2 1

F
E
D
C
B
A

F
E
D
C
B
A

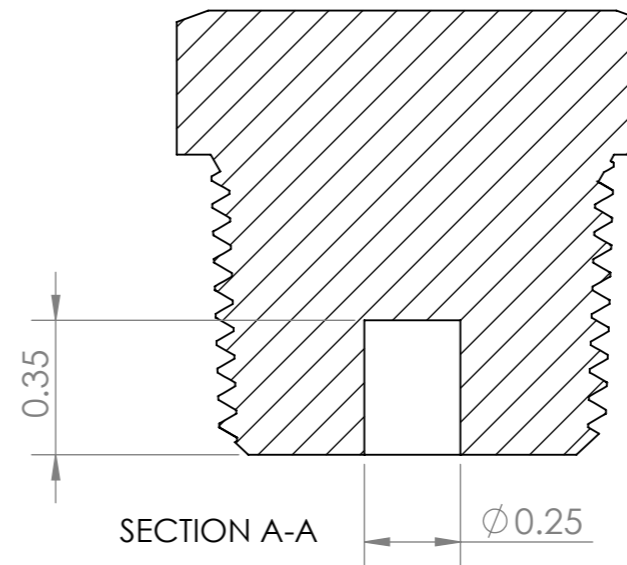
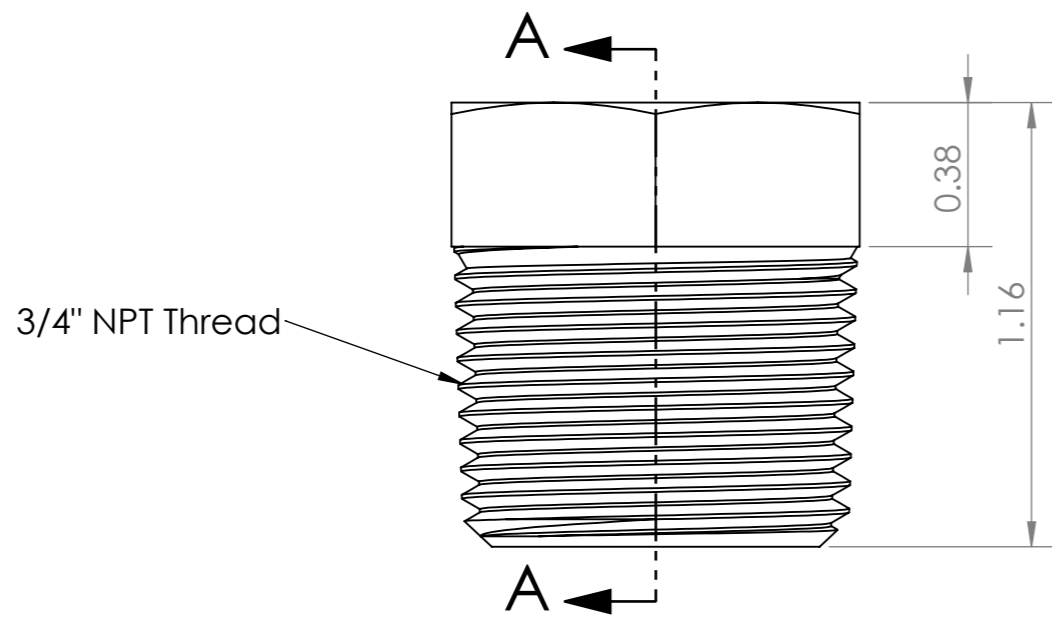
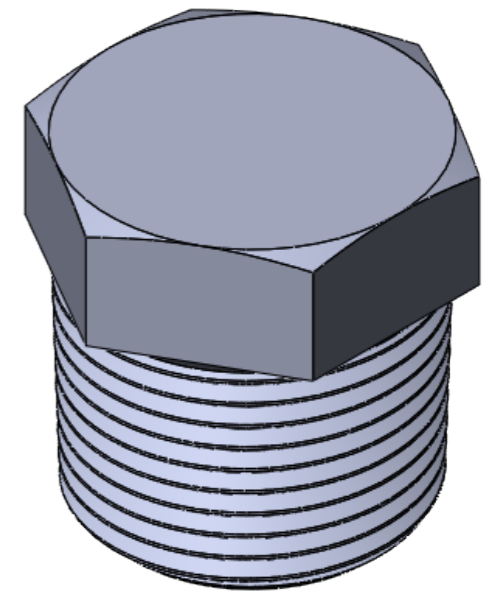
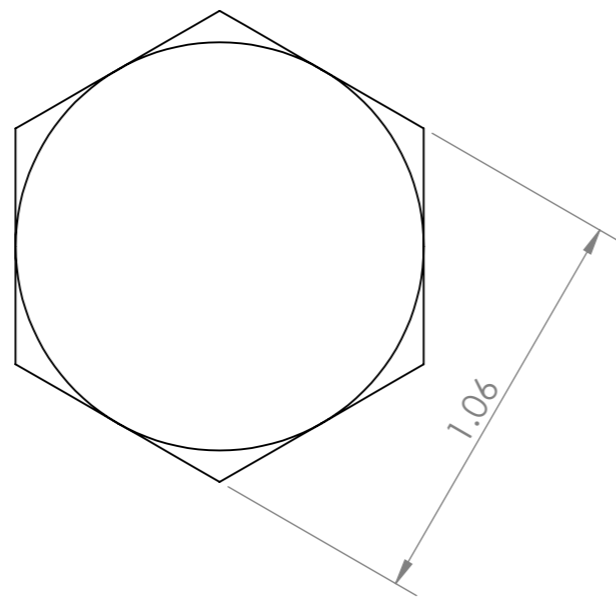

UNLESS OTHERWISE SPECIFIED: DIMENSIONS ARE IN MILLIMETERS SURFACE FINISH: TOLERANCES: LINEAR: ANGULAR:			FINISH:		DEBURR AND BREAK SHARP EDGES		DO NOT SCALE DRAWING		REVISION	
			NAME		SIGNATURE		DATE		TITLE:	
DRAWN			RLD				12/1/23		0.75" NPT Plug With Bottom Counterbore	
CHK'D										
APPV'D										
MFG										
Q.A									DWG NO.	
									A3	
									SCALE:2:1	
									SHEET 1 OF 1	

8 7 6 5 4 3 2 1

F
E
D
C
B
A

F
E
D
C
B
A

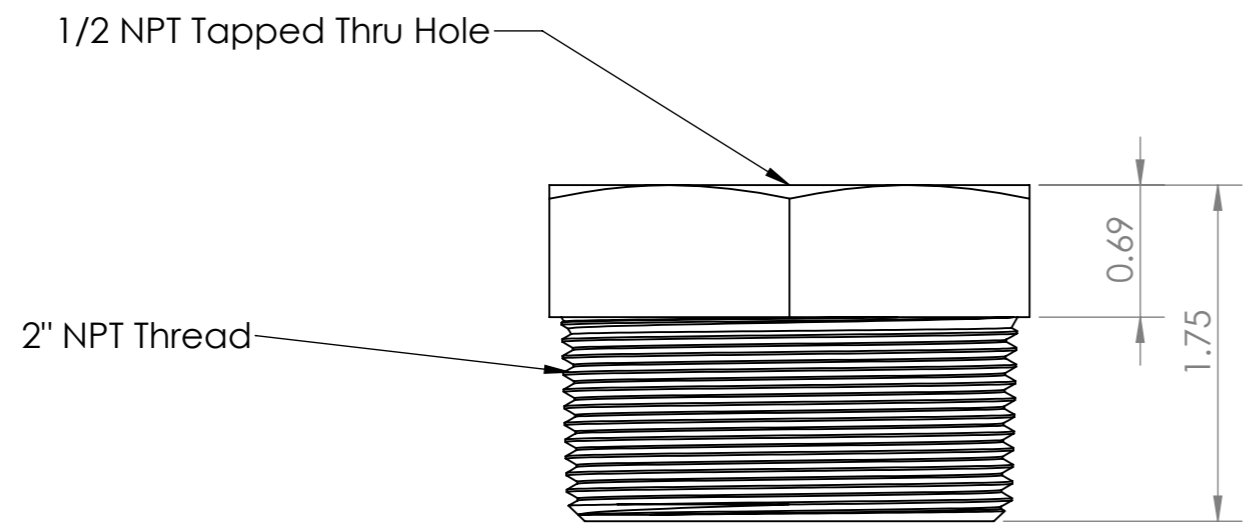
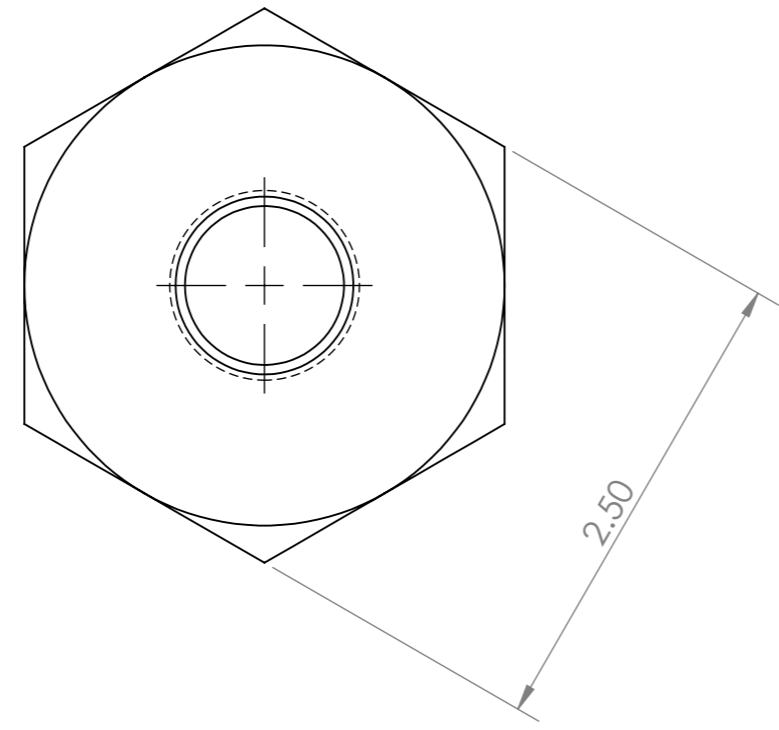

UNLESS OTHERWISE SPECIFIED: DIMENSIONS ARE IN MILLIMETERS SURFACE FINISH: TOLERANCES: LINEAR: ANGULAR:			FINISH:		DEBURR AND BREAK SHARP EDGES		DO NOT SCALE DRAWING		REVISION		
DRAWN			NAME		SIGNATURE		DATE		TITLE:		
CHK'D			RLD				12/1/23		2" NPT Plug With 1/2" NPT Thru Hole		
APPV'D									DWG NO.		
MFG									A3		
Q.A							MATERIAL:		Steel		
							WEIGHT:		SCALE:1:1		
									SHEET 1 OF 1		

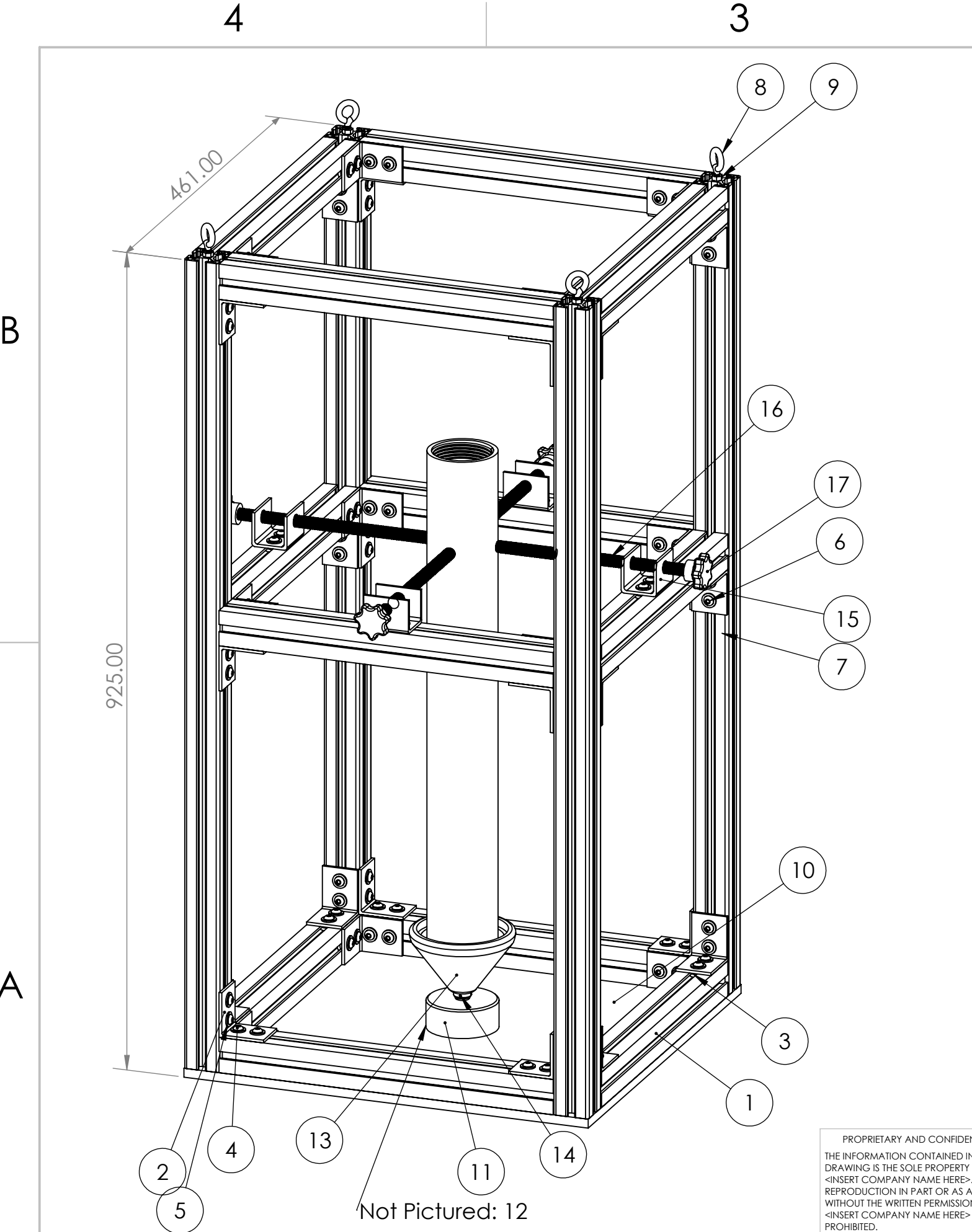

ITEM NO.	PART NUMBER	DESCRIPTION	QTY.
1	Solar Shack Extrusion (15in)	Horizontal Beams	12
2	40mm Bracket	Connects Extrusion To Other Extrusion	36
3	0.25-20 in T-Nut	Slide-In Nut Allows The Extrusion To Be Fastened	152
4	1/4-20 - 1/2" Button Head Screw	For Use On Solar Shack Extrusion	104
5	0.25in Washer (0.625OD)	1/4" Washer	152
6	1/4-20 - 5/8" Button Head Screw	For Use On 4040 Extrusion (3ft)	48
7	4040 Extrusion (3ft)	Vertical Beams	4
8	Eye Bolt	Allows Test Stand To Be Secured With Support Wire	4
9	0.25-20 Nut	Threads On To Eye Bolt To Secure The Threads	4
10	Base Plate	Secures Load Cell And Distributes Load	1
11	Load Cell	Measures Created Thrust	1
12	M6x8mm Flat Head Screw	Secures Load Cell to Base Plate	3
13	Motor Holder	Holds Motor Concentricly, Options for 28mm-96mm	1
14	M2x2mm Set Screw	Secures Motor Holder to Load Cell	4
15	All Thread Brackets	Brackets To House Stabilizing Rods	4
16	1/2-13x9" All Threads	Stabilizes Motor And Keeps It Upright	4
17	Knob	Allows Easy Manipulation of Stabilizing Rods	4
18	20in Motor WITH Casing		1

PROPRIETARY AND CONFIDENTIAL
 THE INFORMATION CONTAINED IN THIS DRAWING IS THE SOLE PROPERTY OF <INSERT COMPANY NAME HERE>. ANY REPRODUCTION IN PART OR AS A WHOLE WITHOUT THE WRITTEN PERMISSION OF <INSERT COMPANY NAME HERE> IS PROHIBITED.

UNLESS OTHERWISE SPECIFIED:		NAME	DATE
DIMENSIONS ARE IN MILLIMETERS		DRAWN	RLD 11/1/23
TOLERANCES:		CHECKED	
FRACTIONAL ±		ENG APPR.	
ANGULAR: MACH ± BEND ±		MFG APPR.	
TWO PLACE DECIMAL ±		Q.A.	
THREE PLACE DECIMAL ±		COMMENTS: All Parts Listed Besides Support Cable And Stakes. Part 12 Hidden Under Base Plate	
INTERPRET GEOMETRIC TOLERANCING PER:		TITLE: Test Stand Final	
MATERIAL		SIZE	DWG. NO.
FINISH		B	
NEXT ASSY	USED ON	REV	
APPLICATION	DO NOT SCALE DRAWING	SCALE: 1:5	WEIGHT:
		SHEET 1 OF 1	

B

A

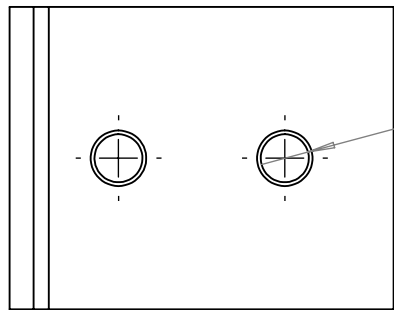

$\phi 0.250$

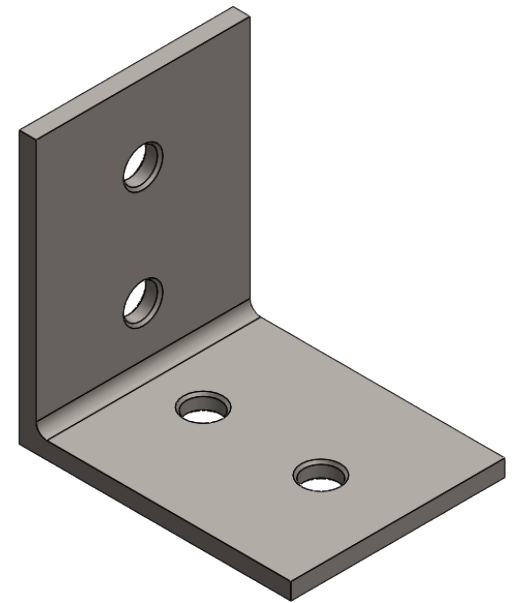
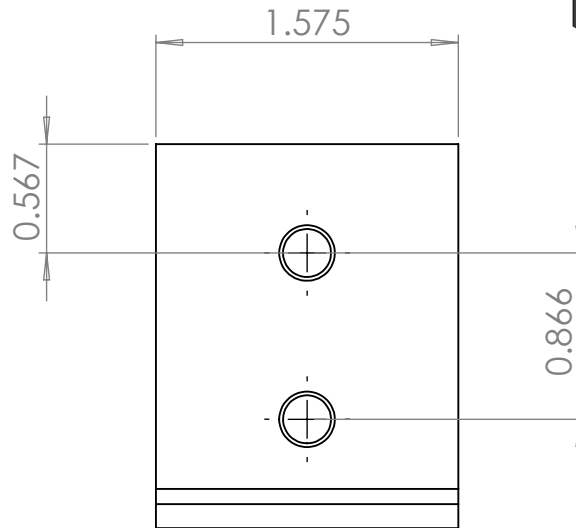
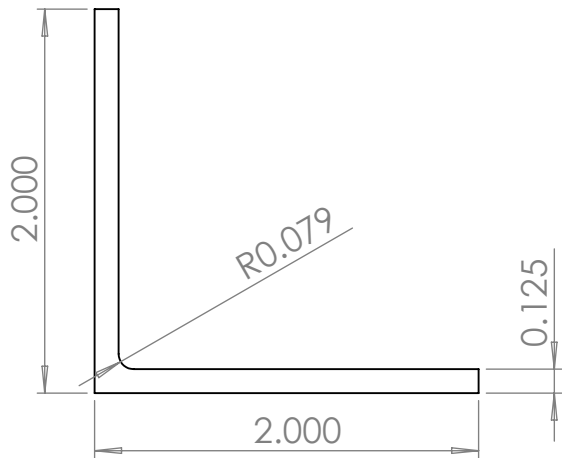

B

A

PROPRIETARY AND CONFIDENTIAL
THE INFORMATION CONTAINED IN THIS
DRAWING IS THE SOLE PROPERTY OF
<INSERT COMPANY NAME HERE>. ANY
REPRODUCTION IN PART OR AS A WHOLE
WITHOUT THE WRITTEN PERMISSION OF
<INSERT COMPANY NAME HERE> IS
PROHIBITED.

		UNLESS OTHERWISE SPECIFIED:		NAME	DATE
		DIMENSIONS ARE IN INCHES	DRAWN	RLD	12/1/23
		TOLERANCES:	CHECKED		
		FRACTIONAL \pm	ENG APPR.		
		ANGULAR: MACH \pm BEND \pm	MFG APPR.		
		TWO PLACE DECIMAL \pm	Q.A.		
		THREE PLACE DECIMAL \pm	COMMENTS:		
		INTERPRET GEOMETRIC TOLERANCING PER:			
		MATERIAL			
NEXT ASSY	USED ON	FINISH			
APPLICATION		DO NOT SCALE DRAWING			

TITLE:
40mm Bracket

SIZE A	DWG. NO.	REV
SCALE: 1:1	WEIGHT:	SHEET 1 OF 1

B

B

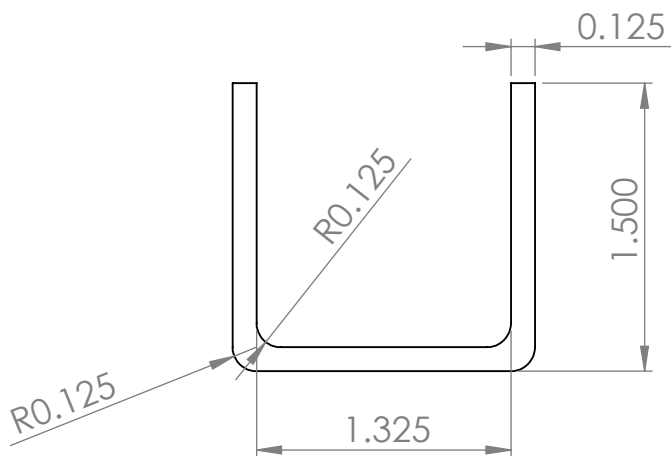
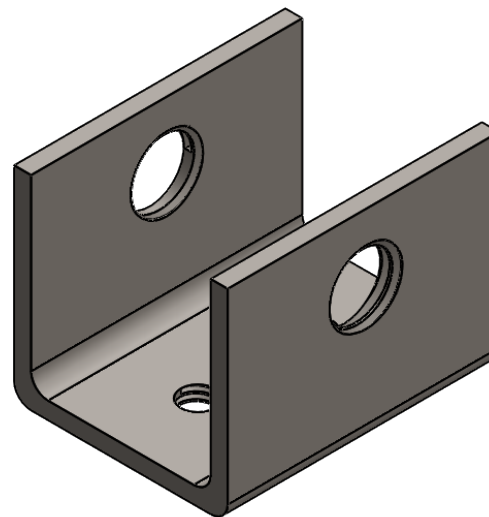
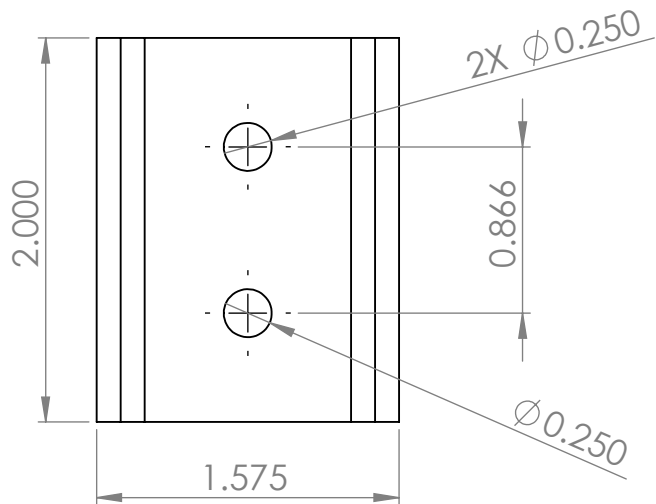

$\phi 0.500$
Drill For 1/2-13 Threads

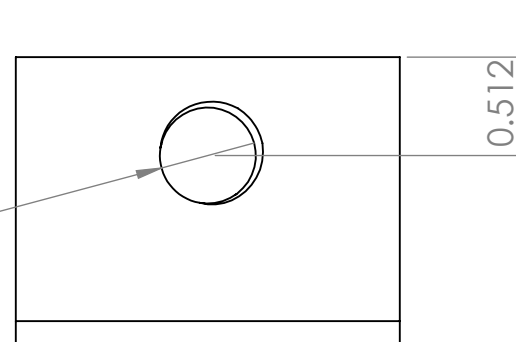

A

A

PROPRIETARY AND CONFIDENTIAL
THE INFORMATION CONTAINED IN THIS
DRAWING IS THE SOLE PROPERTY OF
<INSERT COMPANY NAME HERE>. ANY
REPRODUCTION IN PART OR AS A WHOLE
WITHOUT THE WRITTEN PERMISSION OF
<INSERT COMPANY NAME HERE> IS
PROHIBITED.

		UNLESS OTHERWISE SPECIFIED:		NAME	DATE
		DIMENSIONS ARE IN INCHES	DRAWN	RLD	12/1/23
		TOLERANCES:	CHECKED		
		FRACTIONAL \pm	ENG APPR.		
		ANGULAR: MACH \pm BEND \pm	MFG APPR.		
		TWO PLACE DECIMAL \pm	Q.A.		
		THREE PLACE DECIMAL \pm	COMMENTS:		
		INTERPRET GEOMETRIC TOLERANCING PER:			
		MATERIAL			
		FINISH			
NEXT ASSY	USED ON				
APPLICATION		DO NOT SCALE DRAWING			

TITLE:

All Thread Brackets

SIZE
A

DWG. NO.

REV

SCALE: 1:1

WEIGHT:

SHEET 1 OF 1

2

1

8 7 6 5 4 3 2 1

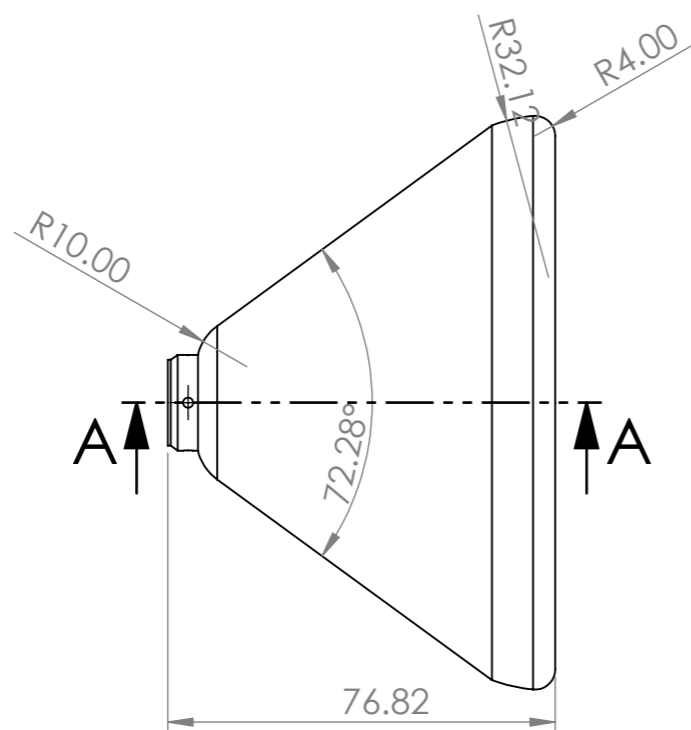
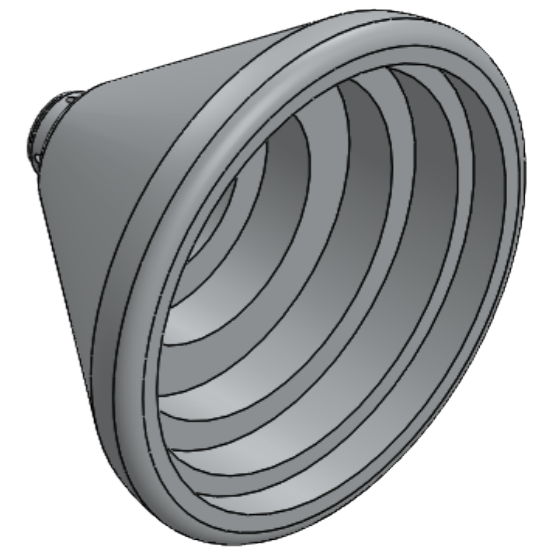
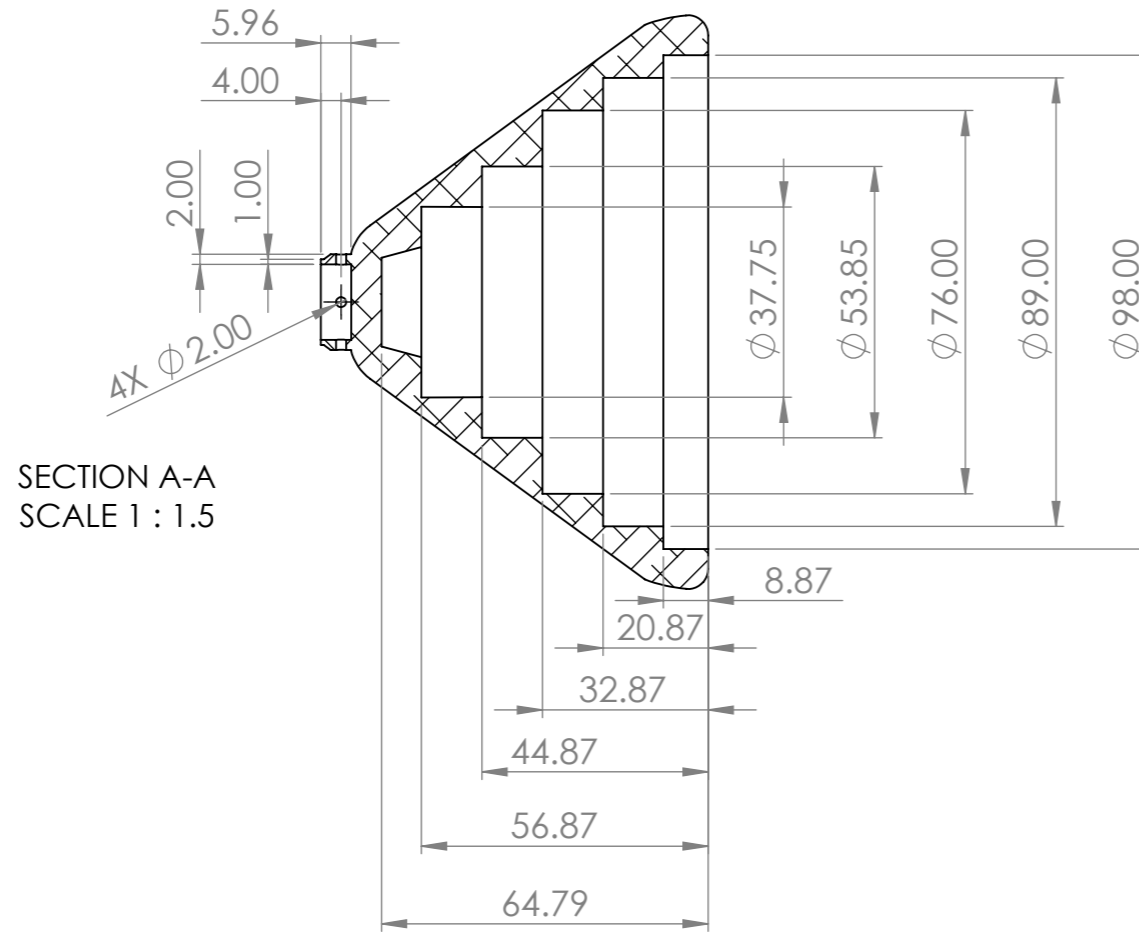

UNLESS OTHERWISE SPECIFIED: DIMENSIONS ARE IN MILLIMETERS SURFACE FINISH: TOLERANCES: LINEAR: ANGULAR:				FINISH:		DEBURR AND BREAK SHARP EDGES		DO NOT SCALE DRAWING		REVISION	
DRAWN RLD				SIGNATURE		DATE 12/1/23		TITLE: Motor Holder			
CHK'D				APPV'D		MFG		Q.A		MATERIAL:	
								DWG NO.		A3	
						WEIGHT:		SCALE: 1:1.5		SHEET 1 OF 1	

8 7 6 5 4 3 2 1

F

F

E

E

D

D

C

C

B

B

A

A

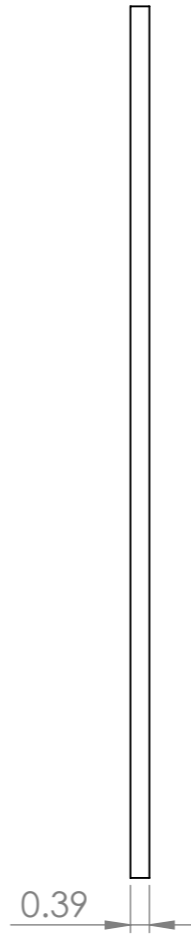
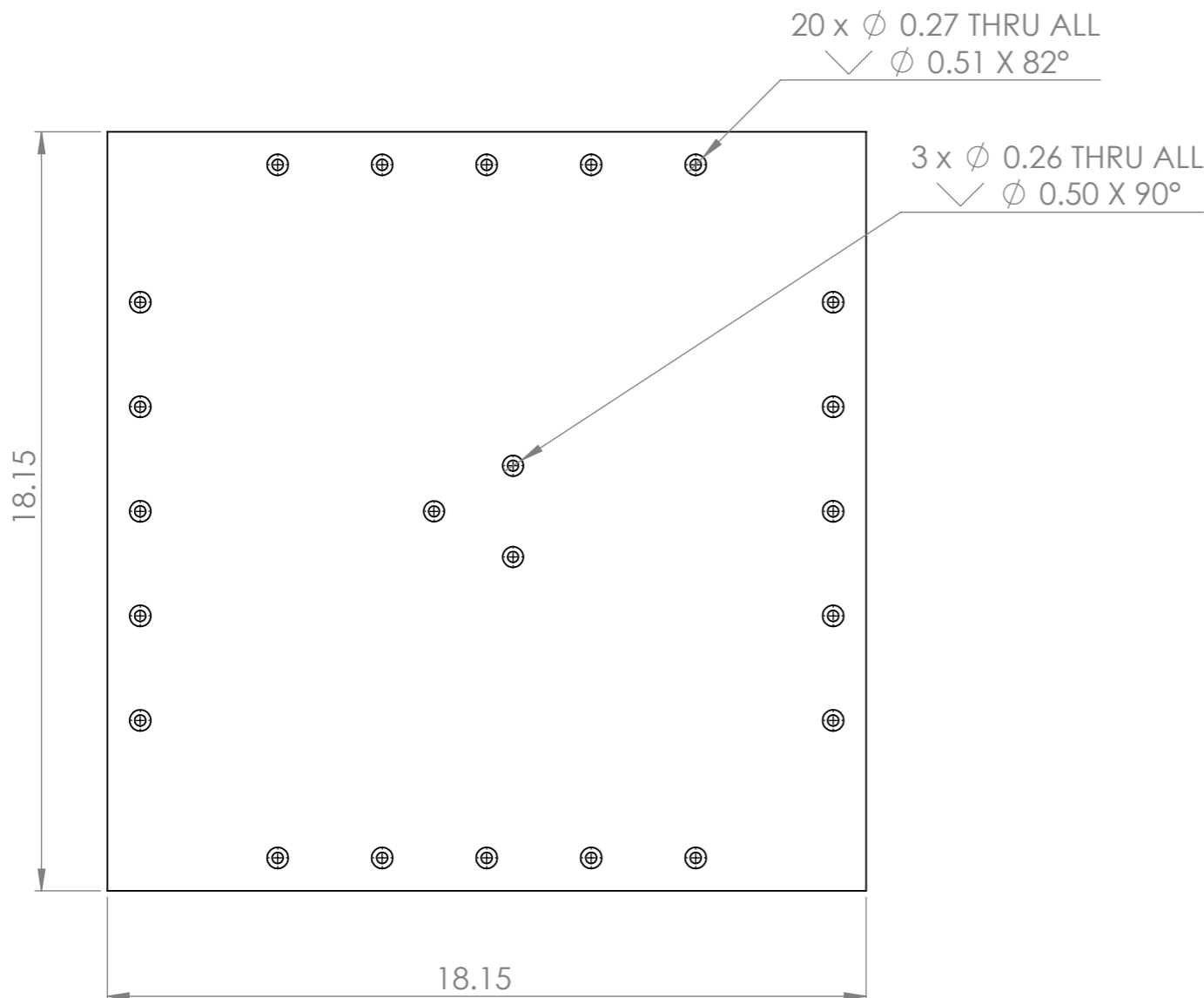
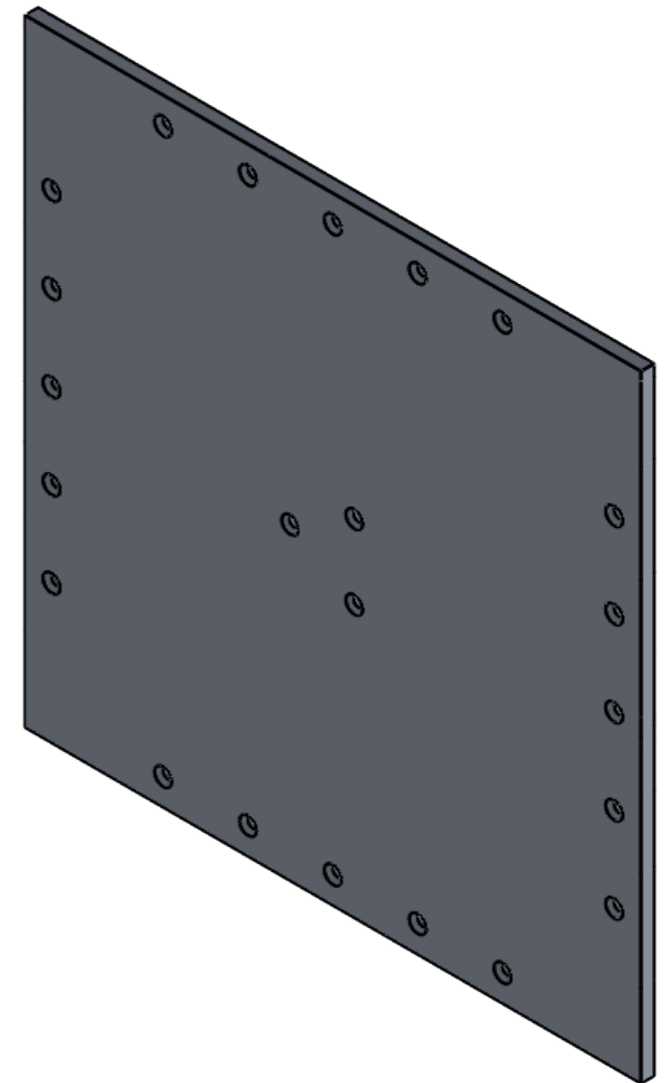

UNLESS OTHERWISE SPECIFIED: DIMENSIONS ARE IN MILLIMETERS SURFACE FINISH: TOLERANCES: LINEAR: ANGULAR:				FINISH:		DEBURR AND BREAK SHARP EDGES		DO NOT SCALE DRAWING		REVISION	
								TITLE: Base Plate			
								DWG NO.			
								SCALE: 1:4			
								SHEET 1 OF 1			
								A3			

8 7 6 5 4 3 2 1

F
E
D
C
B
A

F
E
D
C
B
A

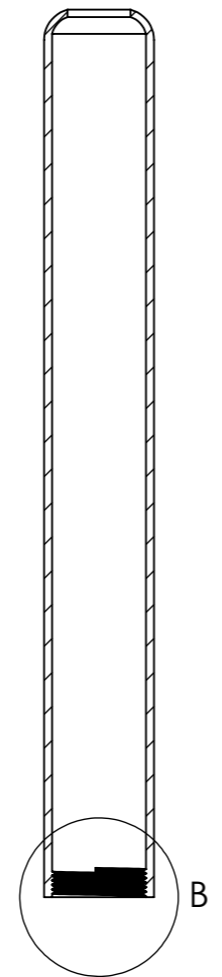
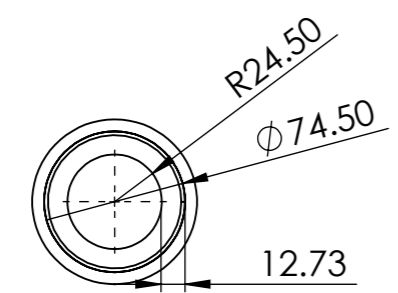
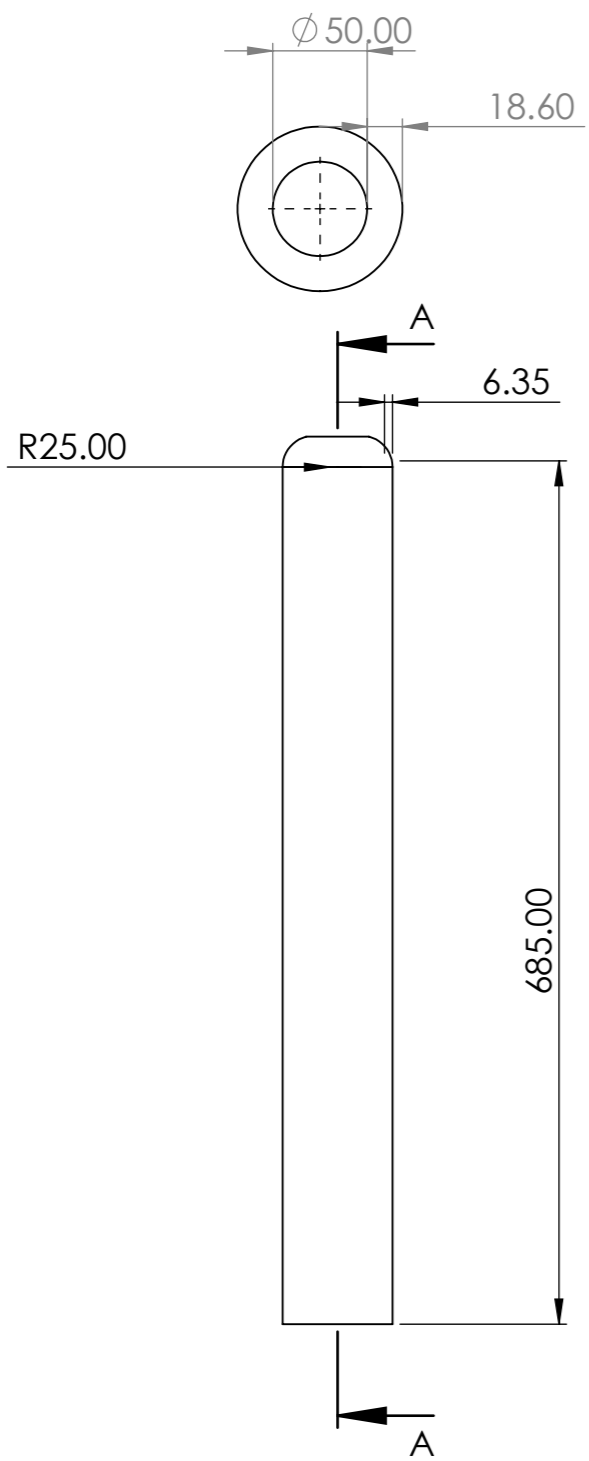

SECTION A-A
SCALE 1 : 6

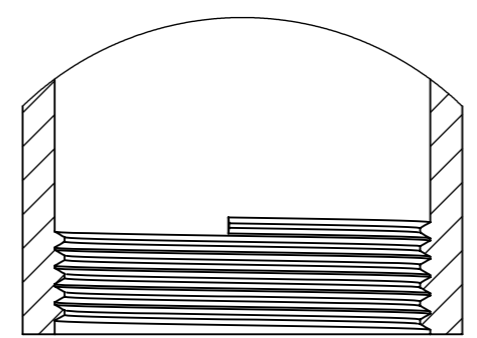

DETAIL B
SCALE 1 : 1.5



TRUE R43.60

UNLESS OTHERWISE SPECIFIED: DIMENSIONS ARE IN MILLIMETERS SURFACE FINISH: TOLERANCES: LINEAR: ANGULAR:		FINISH:	DEBURR AND BREAK SHARP EDGES		DO NOT SCALE DRAWING	REVISION
DRAWN	S.Comstock	SIGNATURE	DATE		TITLE: Motor Casing	
CHK'D						
APPV'D						
MFG						
Q.A				MATERIAL:	DWG NO. 01	A3
				WEIGHT:	SCALE:1:5	SHEET 1 OF 1

8 7 6 5 4 3 2 1

2

1

B

B

A

A

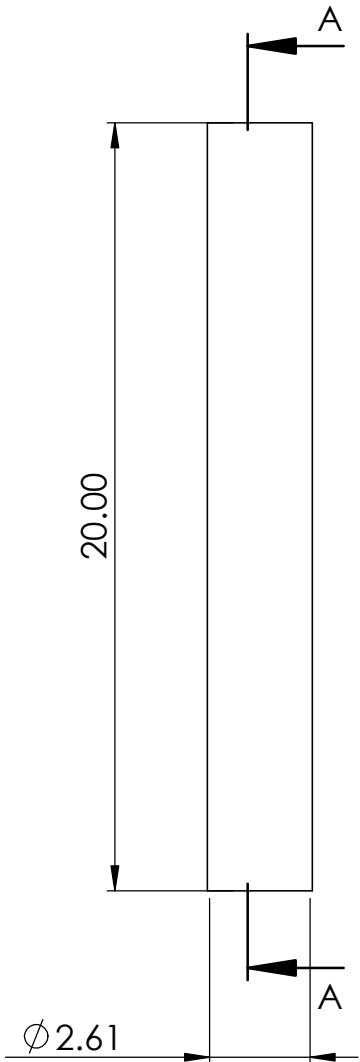

SECTION A-A
SCALE 1 : 5

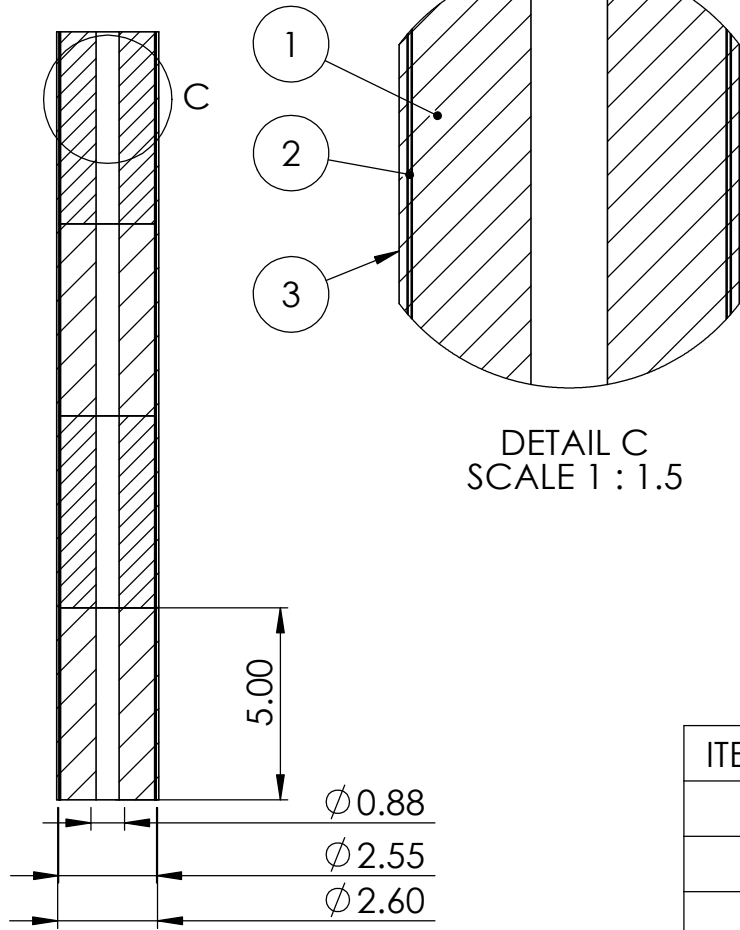

DETAIL C
SCALE 1 : 1.5

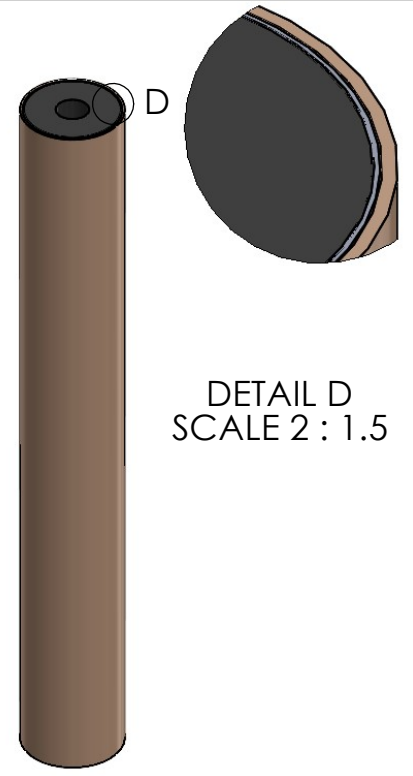

DETAIL D
SCALE 2 : 1.5

ITEM NO.	PART NUMBER	QTY.
1	75mm Grain	4
2	75mm Casting Tube	4
3	75mm 4Grain Liner	1

		UNLESS OTHERWISE SPECIFIED:		NAME	DATE
		DIMENSIONS ARE IN INCHES		DRAWN	GAM 11/4/23
		TOLERANCES:		CHECKED	
		FRACTIONAL ±		ENG APPR.	
		ANGULAR: MACH ± BEND ±		MFG APPR.	
		TWO PLACE DECIMAL ±		Q.A.	
		THREE PLACE DECIMAL ±		COMMENTS:	
		INTERPRET GEOMETRIC TOLERANCING PER:			
		MATERIAL			
NEXT ASSY	USED ON	FINISH			
APPLICATION		DO NOT SCALE DRAWING			

TITLE:		
<h1>75mm Motor</h1>		
SIZE	DWG. NO.	REV
A	Motor	
SCALE: 1:10	WEIGHT:	SHEET 1 OF 1

2

1

8 7 6 5 4 3 2 1

F

F

ITEM NO.	PART NUMBER	DESCRIPTION	QTY.
1	Casing		1
2	Nozzle		1
3	Aft Closure		1
4	Liner		1
5	Insert		1

E

E

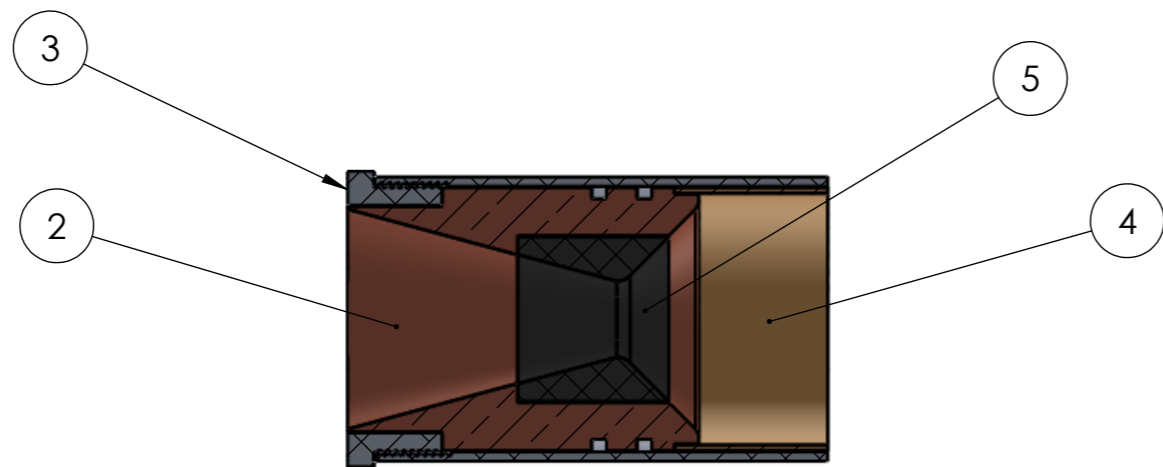
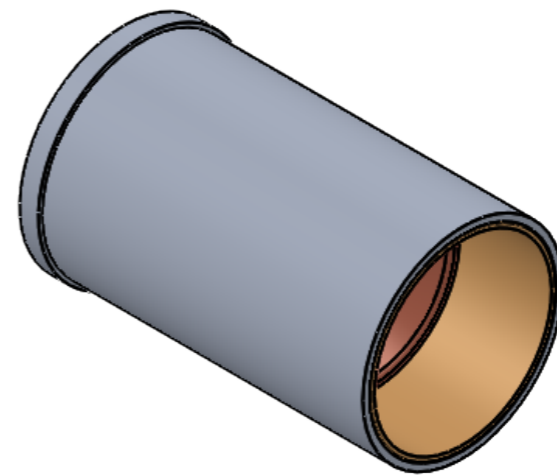

SECTION A-A

D

D

C

C

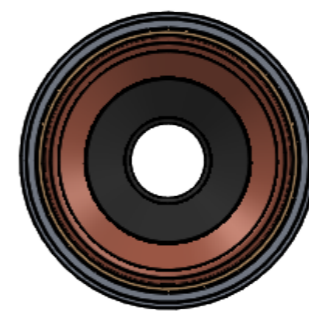
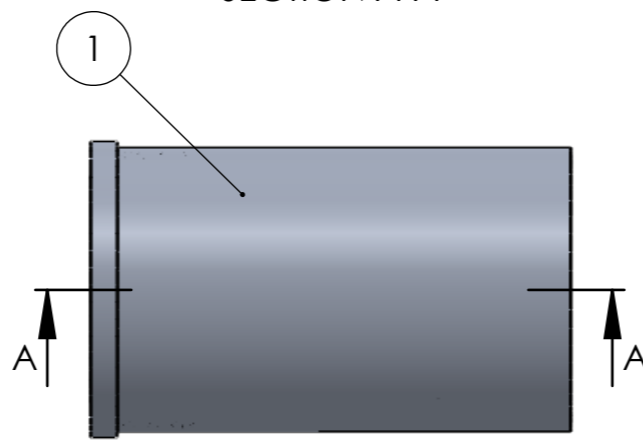
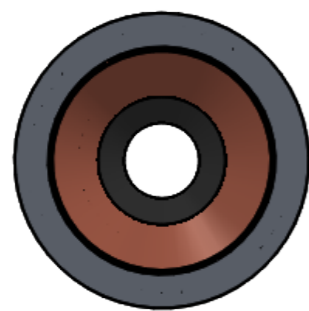

B

B

UNLESS OTHERWISE SPECIFIED: DIMENSIONS ARE IN MILLIMETERS SURFACE FINISH: TOLERANCES: LINEAR: ANGULAR:			FINISH:	DEBURR AND BREAK SHARP EDGES	DO NOT SCALE DRAWING	REVISION
DRAWN	NAME Andrew King	SIGNATURE	DATE 12/1/2023		TITLE: Threaded Design	
CHK'D					DWG NO.	A3
APPV'D				MATERIAL:	SCALE:1:2	
MFG				WEIGHT:	SHEET 1 OF 1	
Q.A						

A

A

8 7 6 5 4 3 2 1

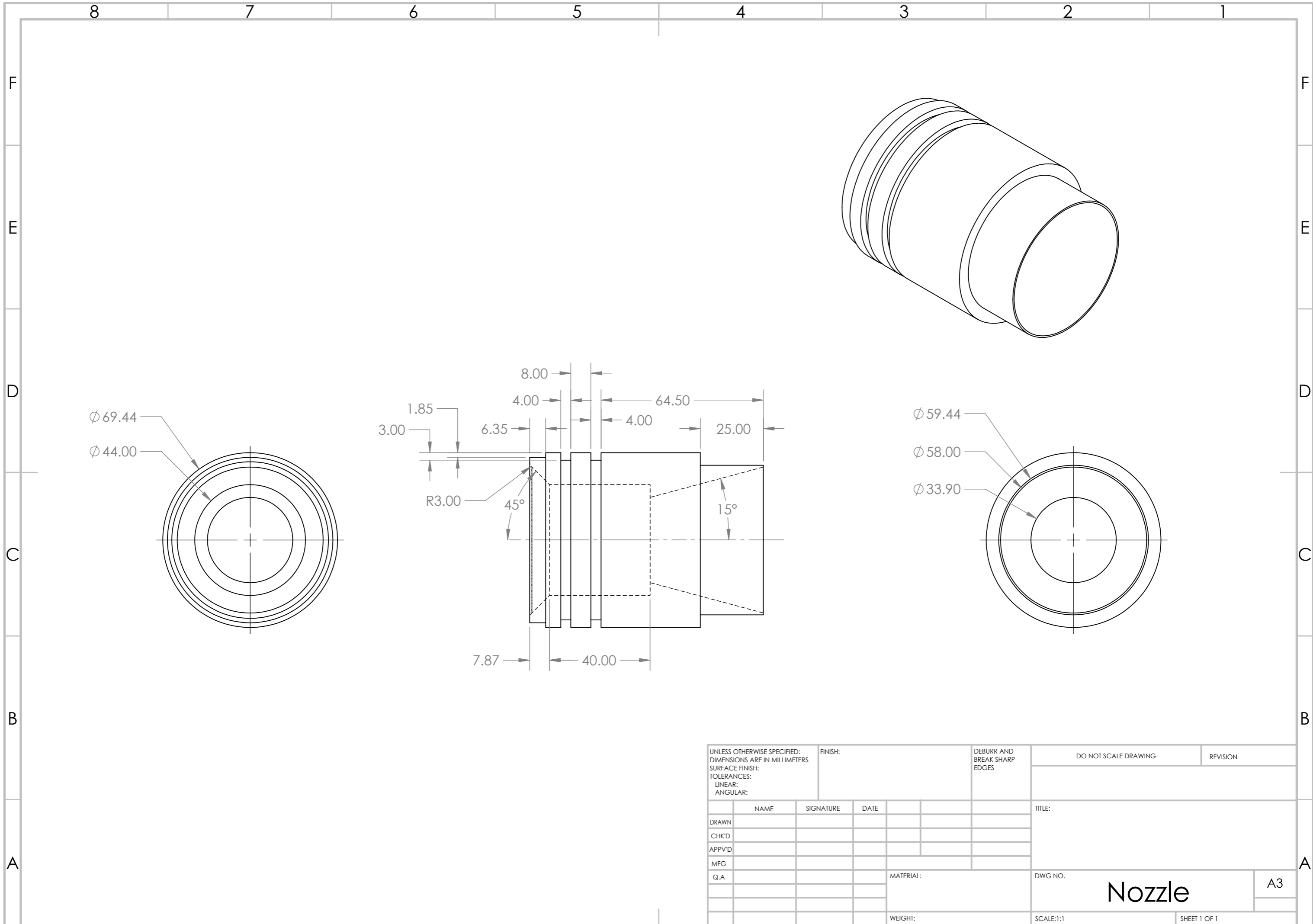

UNLESS OTHERWISE SPECIFIED: DIMENSIONS ARE IN MILLIMETERS SURFACE FINISH: TOLERANCES: LINEAR: ANGULAR:			FINISH:		DEBURR AND BREAK SHARP EDGES		DO NOT SCALE DRAWING		REVISION		
DRAWN			NAME		SIGNATURE		DATE		TITLE:		
CHK'D											
APPV'D											
MFG											
Q.A							MATERIAL:		DWG NO.		
									Nozzle		
							WEIGHT:		SCALE:1:1		
									SHEET 1 OF 1		
									A3		

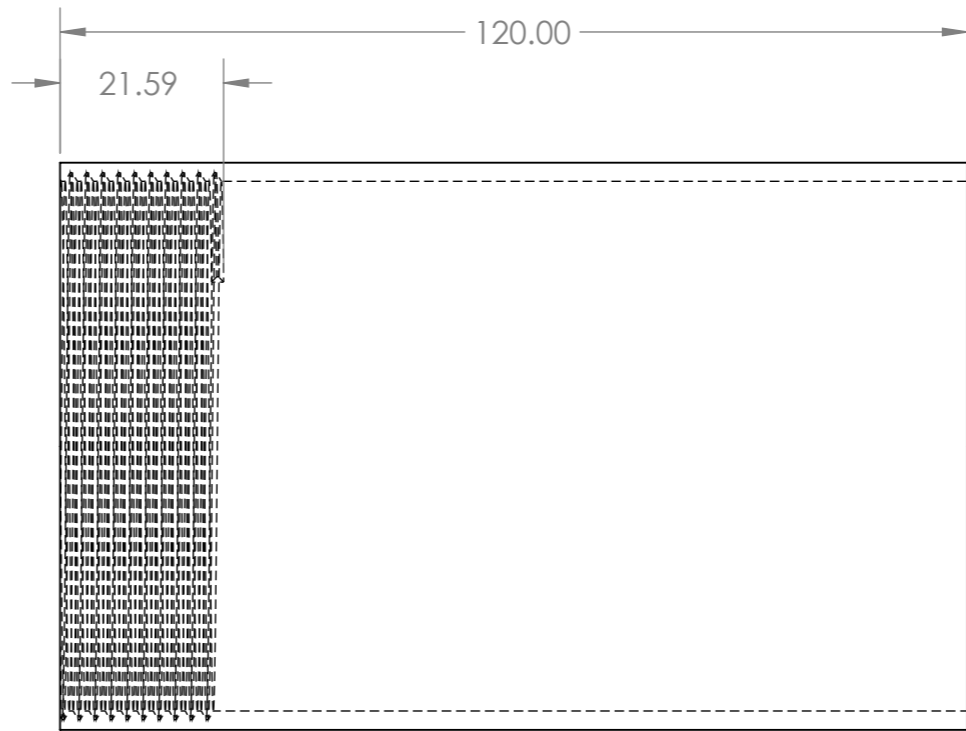
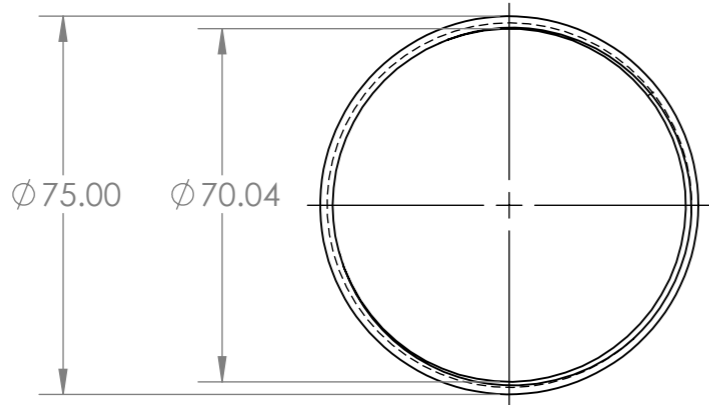
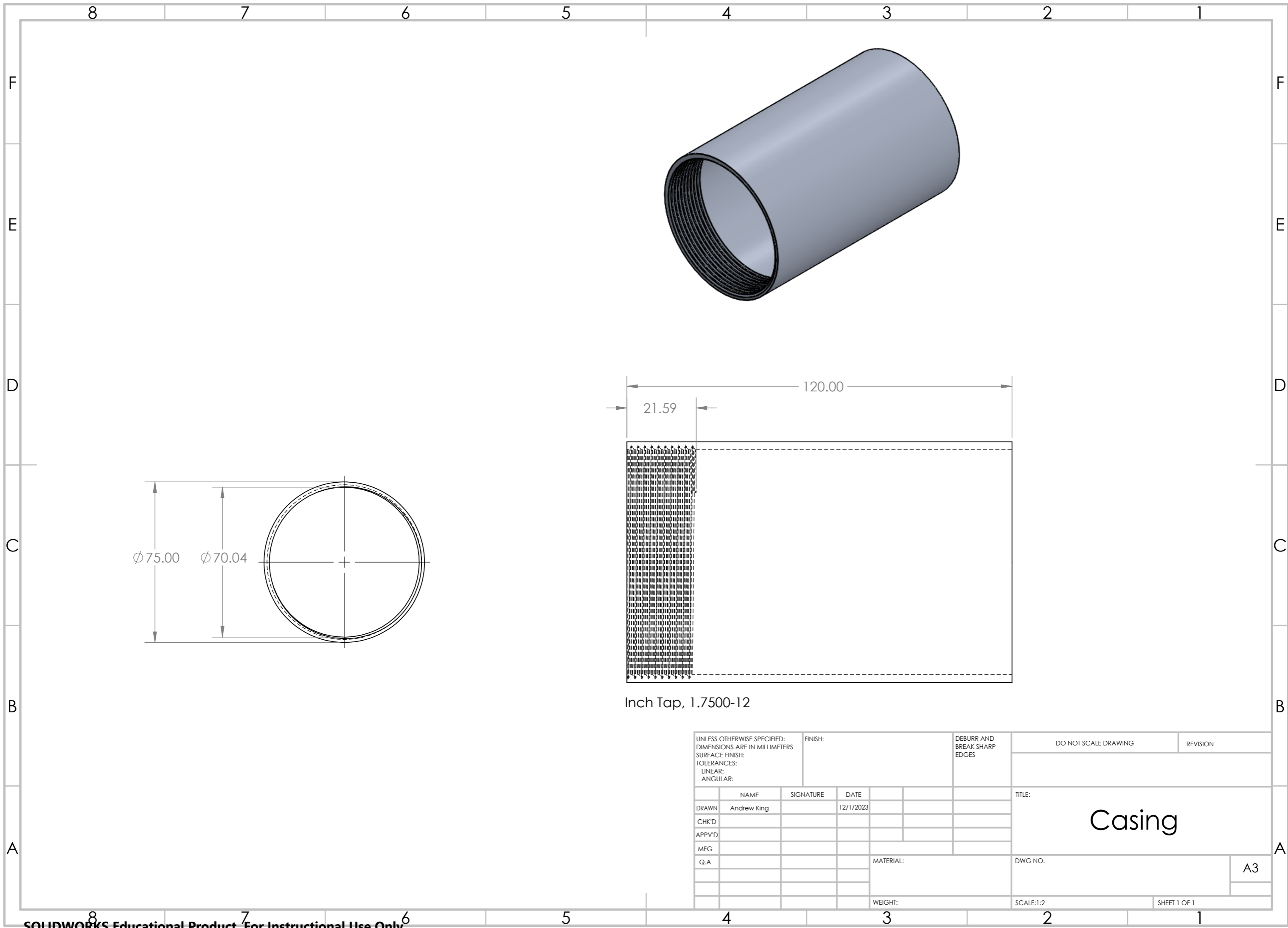

Inch Tap, 1.7500-12

UNLESS OTHERWISE SPECIFIED: DIMENSIONS ARE IN MILLIMETERS SURFACE FINISH: TOLERANCES: LINEAR: ANGULAR:			FINISH:		DEBURR AND BREAK SHARP EDGES		DO NOT SCALE DRAWING		REVISION		
DRAWN Andrew King			SIGNATURE		DATE 12/1/2023		TITLE: <h1>Casing</h1>				
CHK'D			MFG		Q.A		MATERIAL:		DWG NO.		
APPV'D			WEIGHT:		SCALE:1:2		SHEET 1 OF 1				
A3											

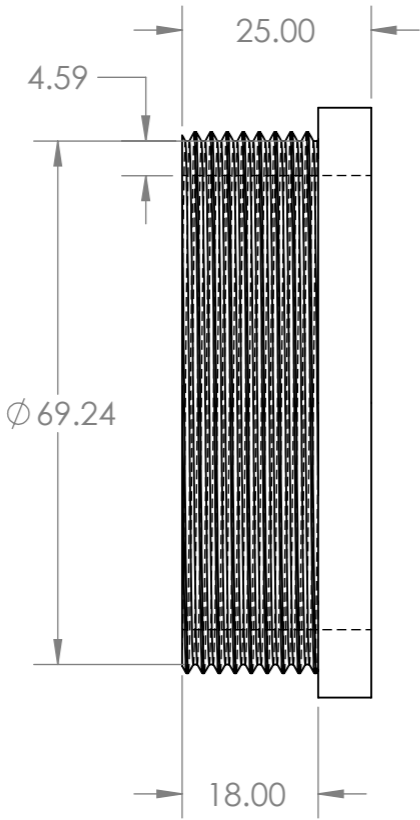
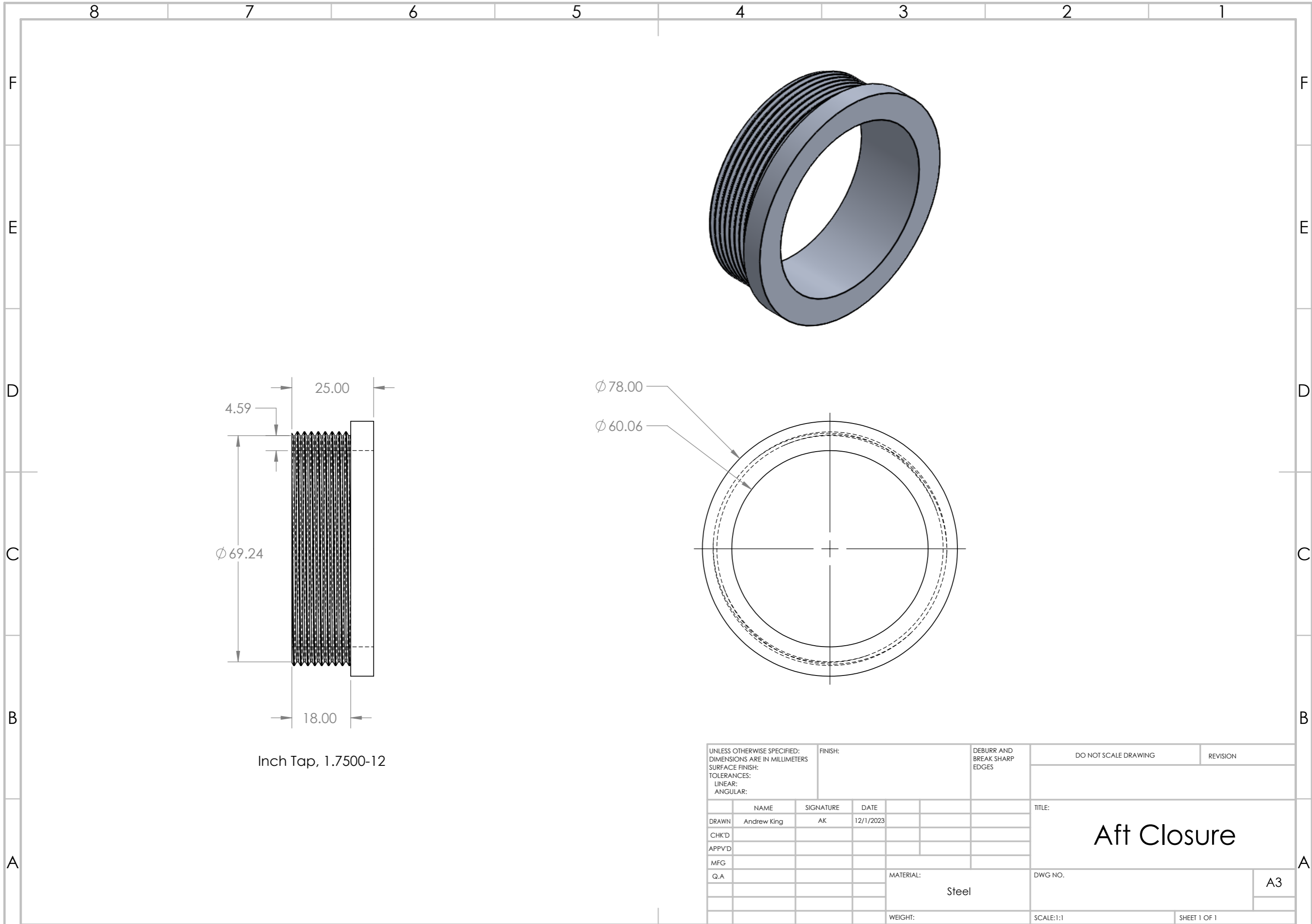

Inch Tap, 1.7500-12

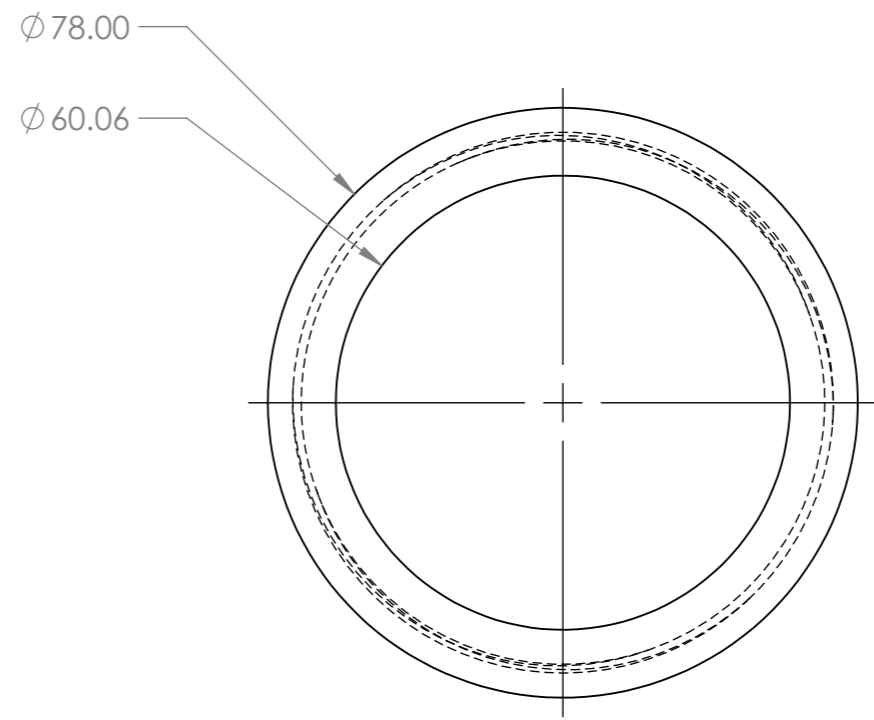

UNLESS OTHERWISE SPECIFIED: DIMENSIONS ARE IN MILLIMETERS SURFACE FINISH: TOLERANCES: LINEAR: ANGULAR:				FINISH:		DEBURR AND BREAK SHARP EDGES		DO NOT SCALE DRAWING		REVISION	
DRAWN Andrew King				SIGNATURE AK		DATE 12/1/2023		TITLE: <h1>Aft Closure</h1>			
CHK'D											
APPV'D											
MFG											
Q.A											
MATERIAL: Steel						DWG NO. A3					
WEIGHT:						SCALE:1:1 SHEET 1 OF 1					

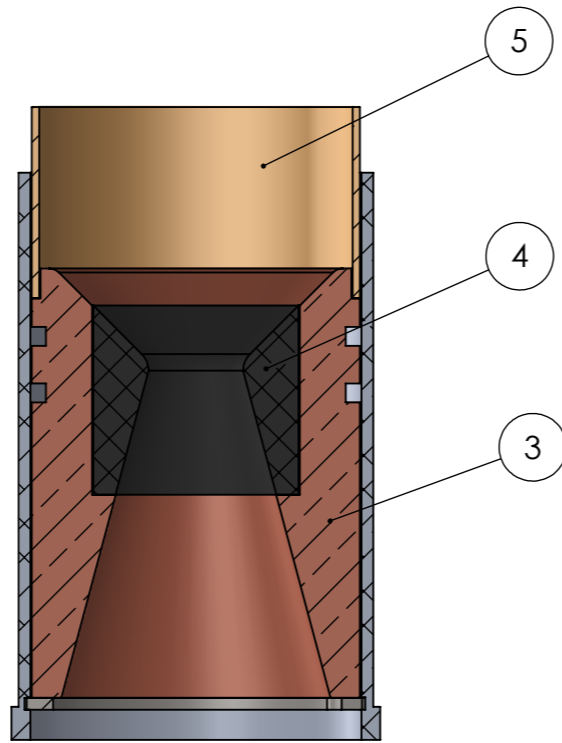
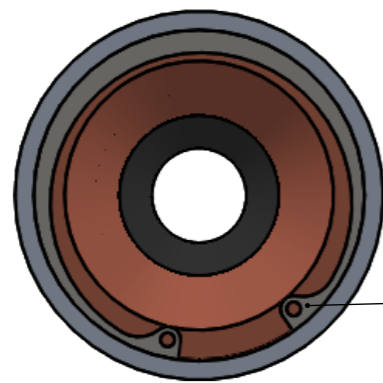
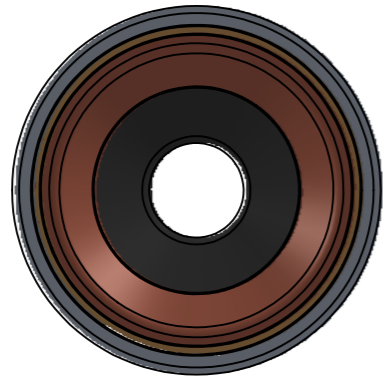

SECTION A-A
SCALE 1 : 1.6

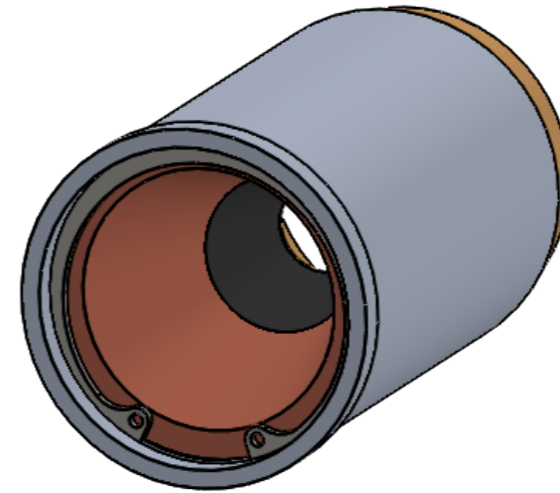

ITEM NO.	PART NUMBER	DESCRIPTION	QTY.
1	Casing for Snap Ring		1
2	98455A423	Internal Retaining Ring	1
3	Nozzle Snap Ring		1
4	Insert		1
5	Liner		1

UNLESS OTHERWISE SPECIFIED: DIMENSIONS ARE IN MILLIMETERS SURFACE FINISH: TOLERANCES: LINEAR: ANGULAR:			FINISH:		DEBURR AND BREAK SHARP EDGES		DO NOT SCALE DRAWING		REVISION		
DRAWN Andrew King			SIGNATURE		DATE 12/1/2023		TITLE: Snap Ring Design				
CHK'D			MFG		Q.A		MATERIAL:		DWG NO.		
APPV'D			WEIGHT:		SCALE:1:2		SHEET 1 OF 1				
									A3		

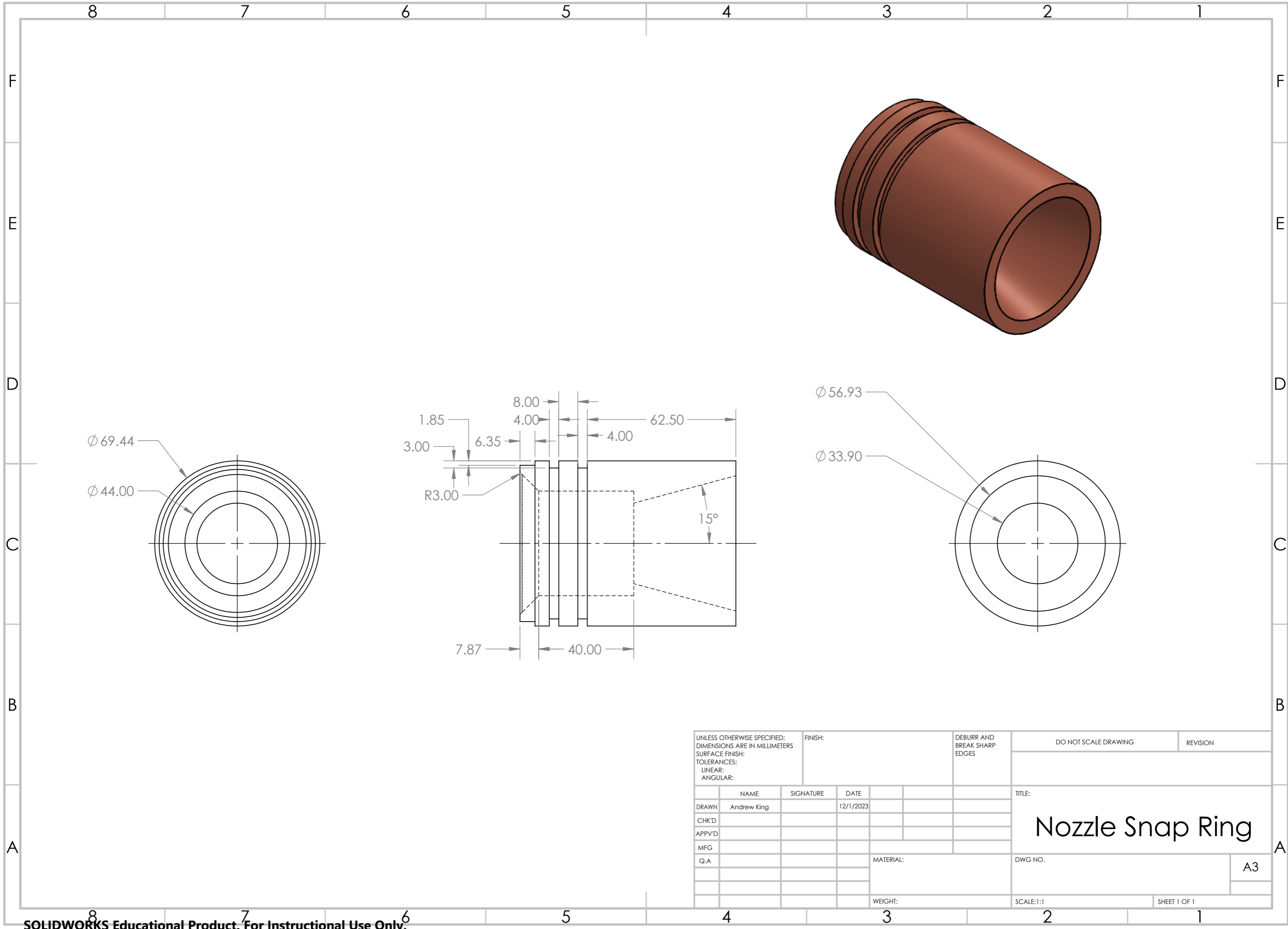

UNLESS OTHERWISE SPECIFIED: DIMENSIONS ARE IN MILLIMETERS SURFACE FINISH: TOLERANCES: LINEAR: ANGULAR:				FINISH:		DEBURR AND BREAK SHARP EDGES		DO NOT SCALE DRAWING		REVISION	
DRAWN Andrew King				SIGNATURE		DATE 12/1/2023		TITLE: Nozzle Snap Ring			
CHK'D				APPV'D		MFG		Q.A		MATERIAL:	
								DWG NO.		A3	
								WEIGHT:		SCALE:1:1	
								SHEET 1 OF 1			

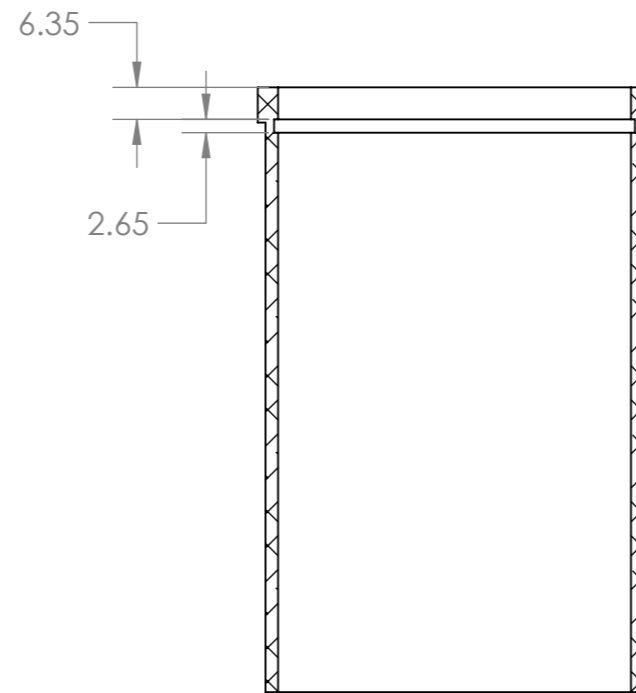
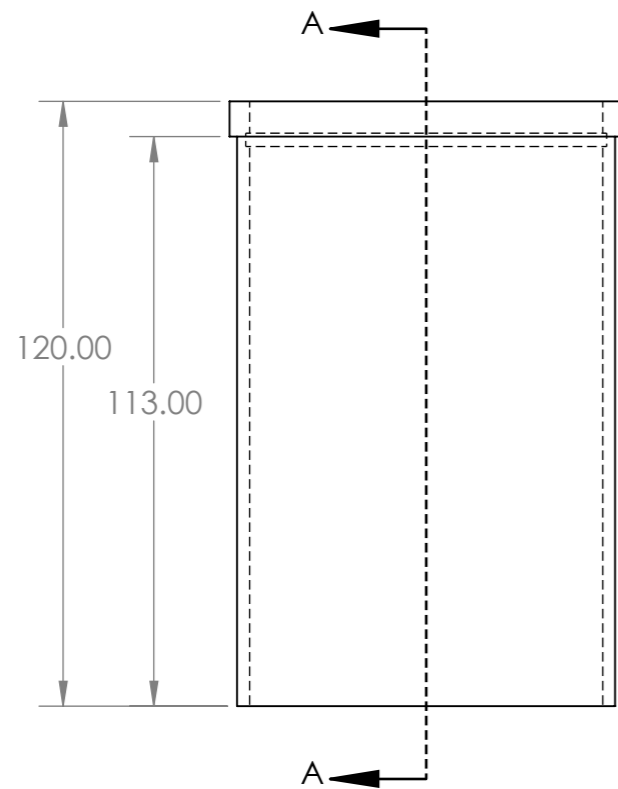
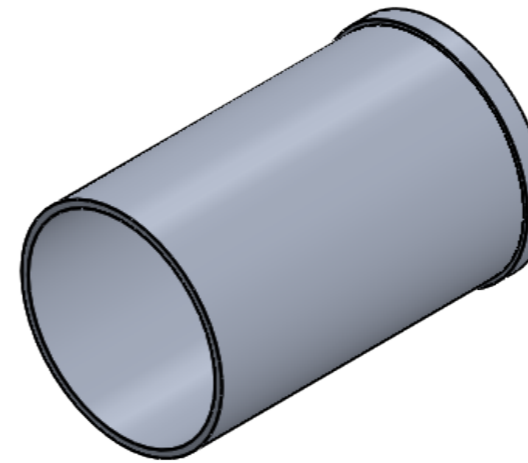
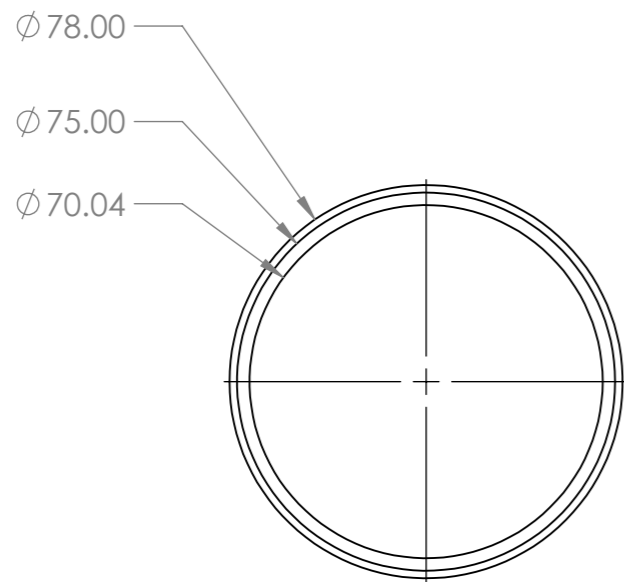

SECTION A-A
SCALE 1 : 1.5

UNLESS OTHERWISE SPECIFIED: DIMENSIONS ARE IN MILLIMETERS SURFACE FINISH: TOLERANCES: LINEAR: ANGULAR:			FINISH:		DEBURR AND BREAK SHARP EDGES		DO NOT SCALE DRAWING		REVISION		
DRAWN Andrew King			SIGNATURE		DATE 12/1/2023		TITLE: Casing for Snap Ring				
CHK'D							DWG NO.				
APPV'D							A3				
MFG							MATERIAL:				
Q.A							WEIGHT:				
							SCALE:1:2				
							SHEET 1 OF 1				

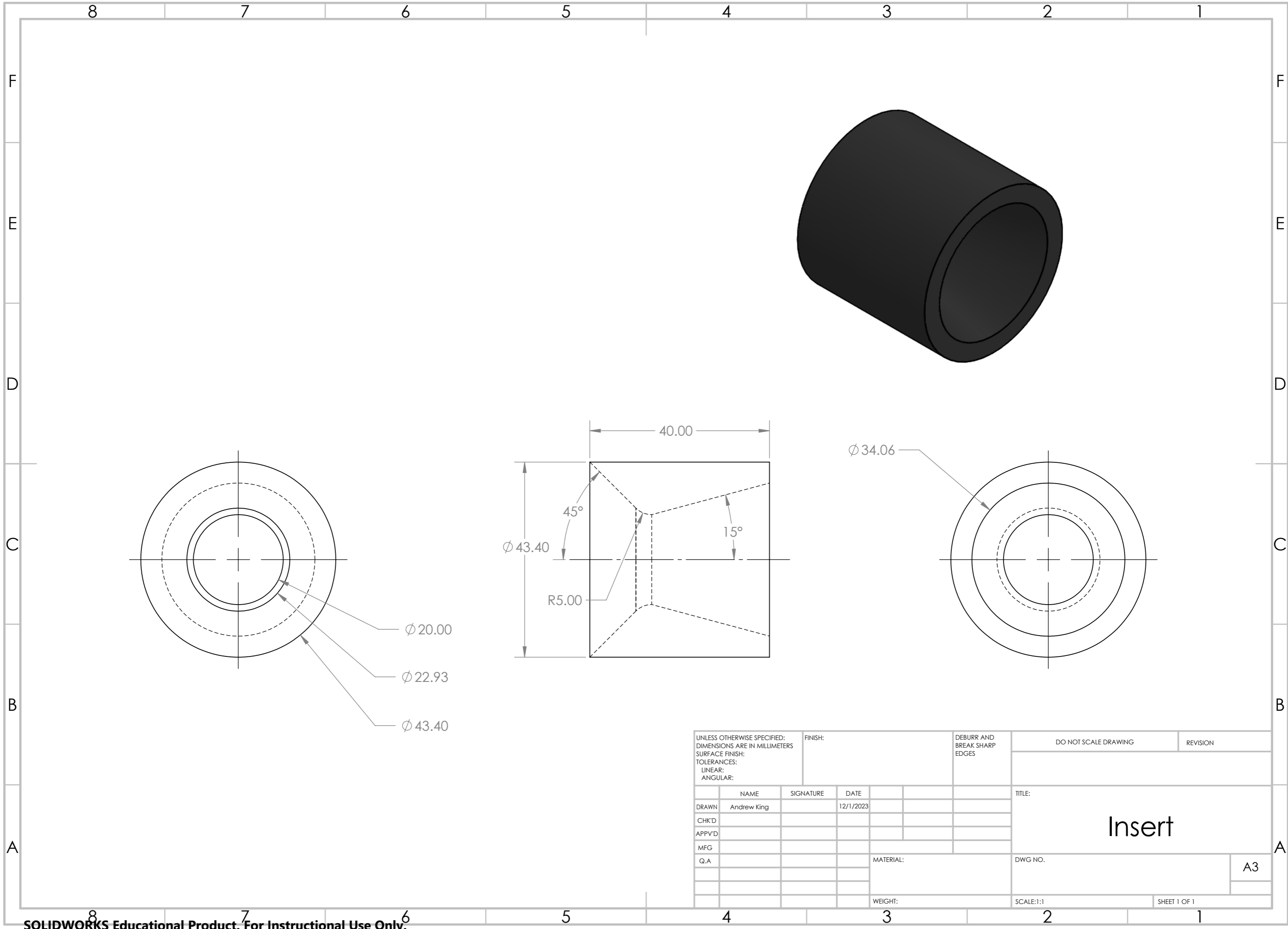

UNLESS OTHERWISE SPECIFIED: DIMENSIONS ARE IN MILLIMETERS SURFACE FINISH: TOLERANCES: LINEAR: ANGULAR:				FINISH:		DEBURR AND BREAK SHARP EDGES		DO NOT SCALE DRAWING		REVISION	
DRAWN				NAME		SIGNATURE		DATE		TITLE:	
CHK'D				Andrew King				12/1/2023		Insert	
APPV'D											
MFG											
Q.A											
								MATERIAL:		DWG NO.	
										A3	
								WEIGHT:		SCALE:1:1	
										SHEET 1 OF 1	

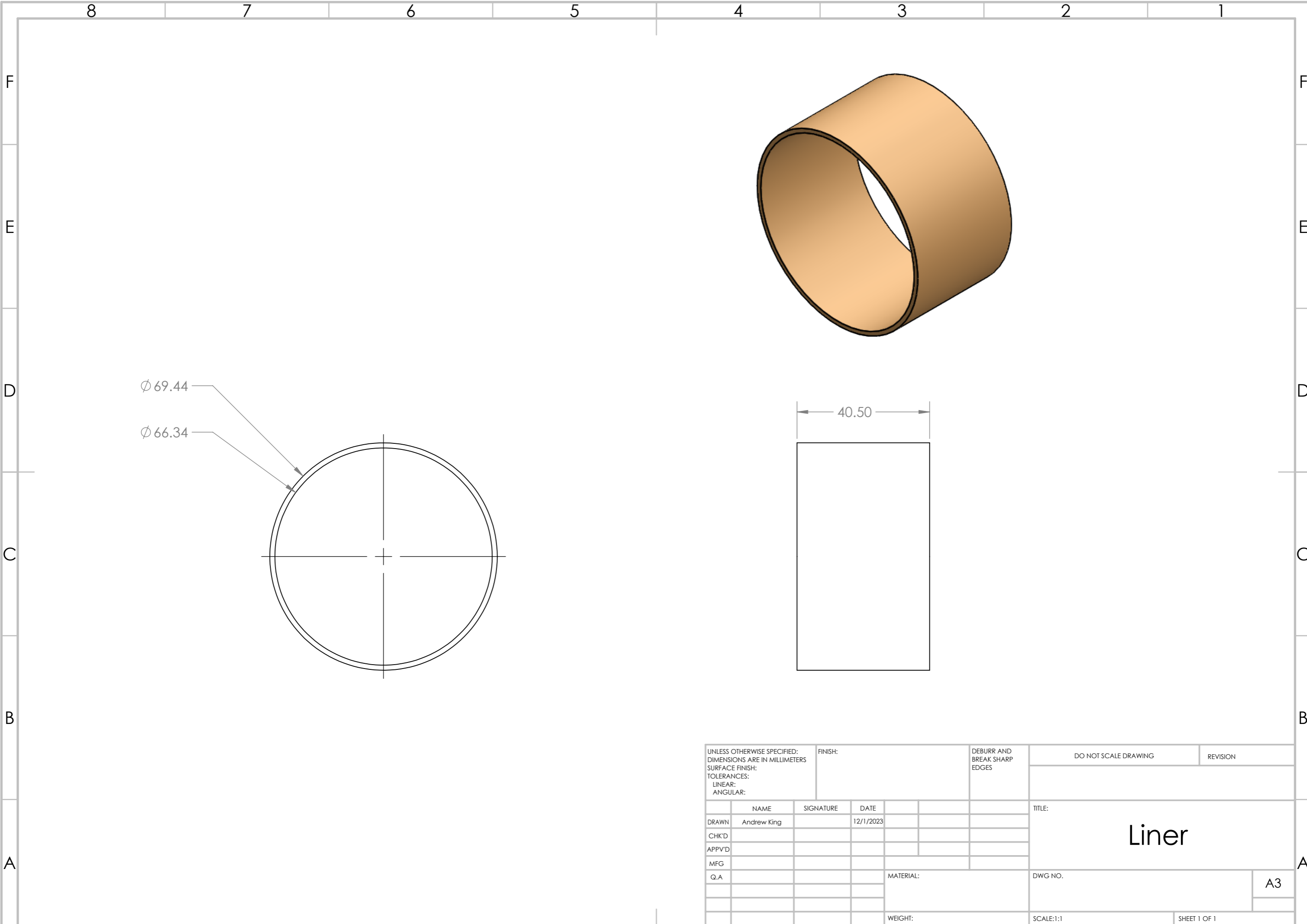

UNLESS OTHERWISE SPECIFIED: DIMENSIONS ARE IN MILLIMETERS SURFACE FINISH: TOLERANCES: LINEAR: ANGULAR:				FINISH:		DEBURR AND BREAK SHARP EDGES		DO NOT SCALE DRAWING		REVISION	
	NAME	SIGNATURE	DATE			TITLE: Liner					
DRAWN	Andrew King		12/1/2023								
CHK'D											
APPV'D											
MFG											
Q.A					MATERIAL:	DWG NO.			A3		
					WEIGHT:	SCALE:1:1			SHEET 1 OF 1		