

SAE Baja '24 Front End

66% Hardware Check

Abraham Plis, Evan Kamp, Bryce Fennell

Design Efforts – Front CAD

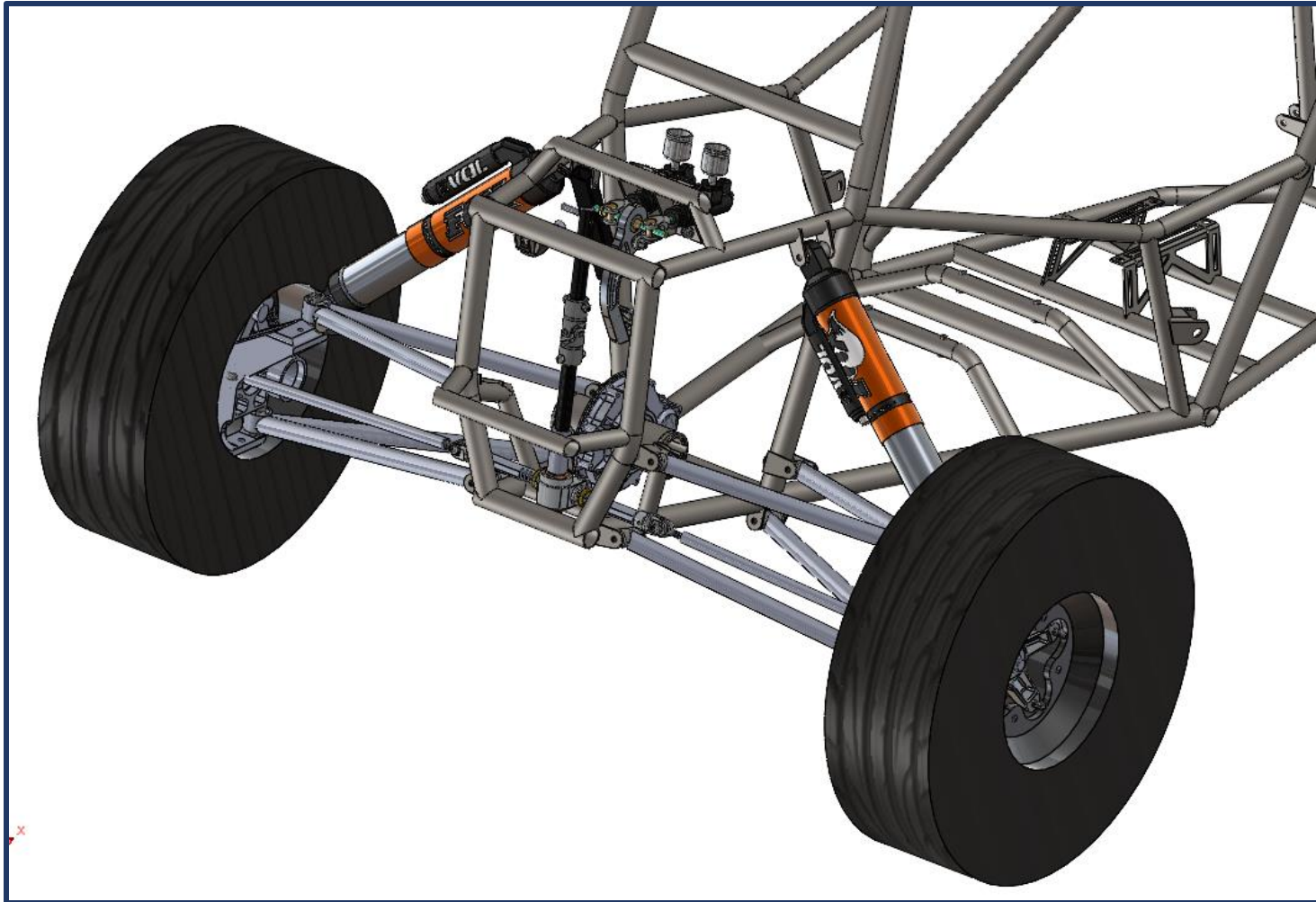

Front End “Zones”

1. Suspension
2. Steering
3. Brake/Throttle

Design Efforts – Front CAD

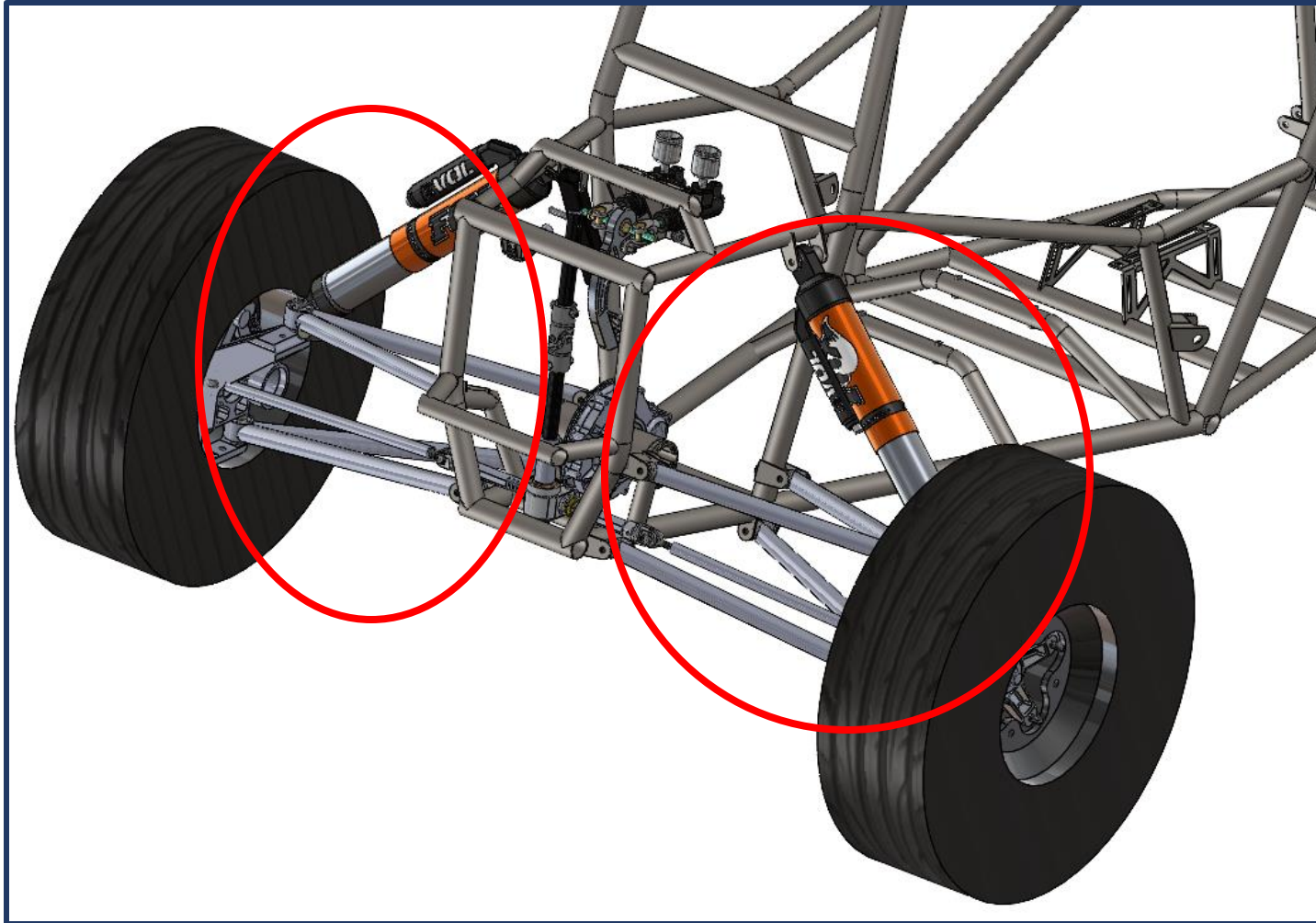

Front End “Zones”

1. Suspension
2. Steering
3. Brake/Throttle

Design Efforts – Front CAD

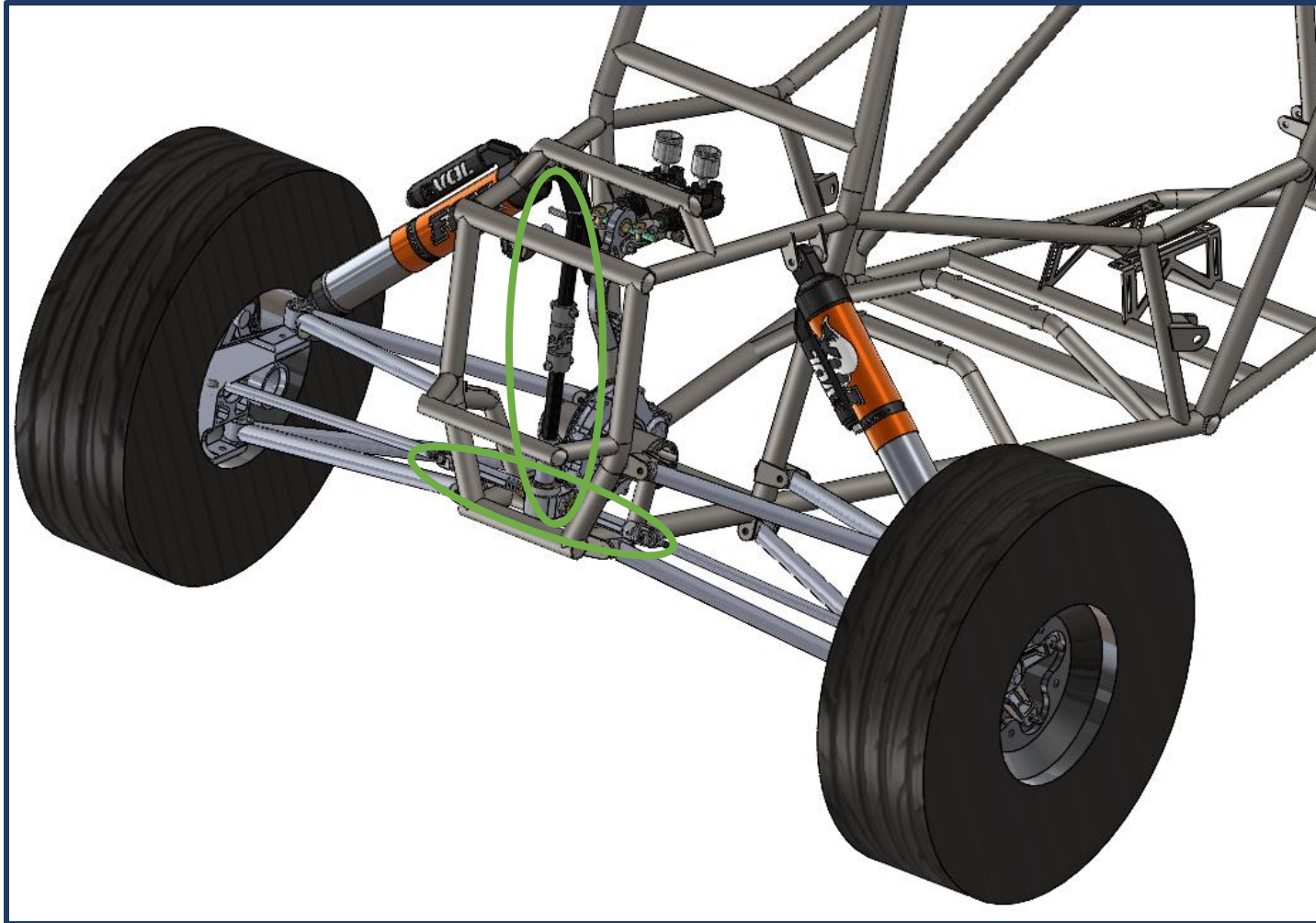

Front End “Zones”

1. Suspension
2. Steering
3. Brake/Throttle

Design Efforts – Front CAD

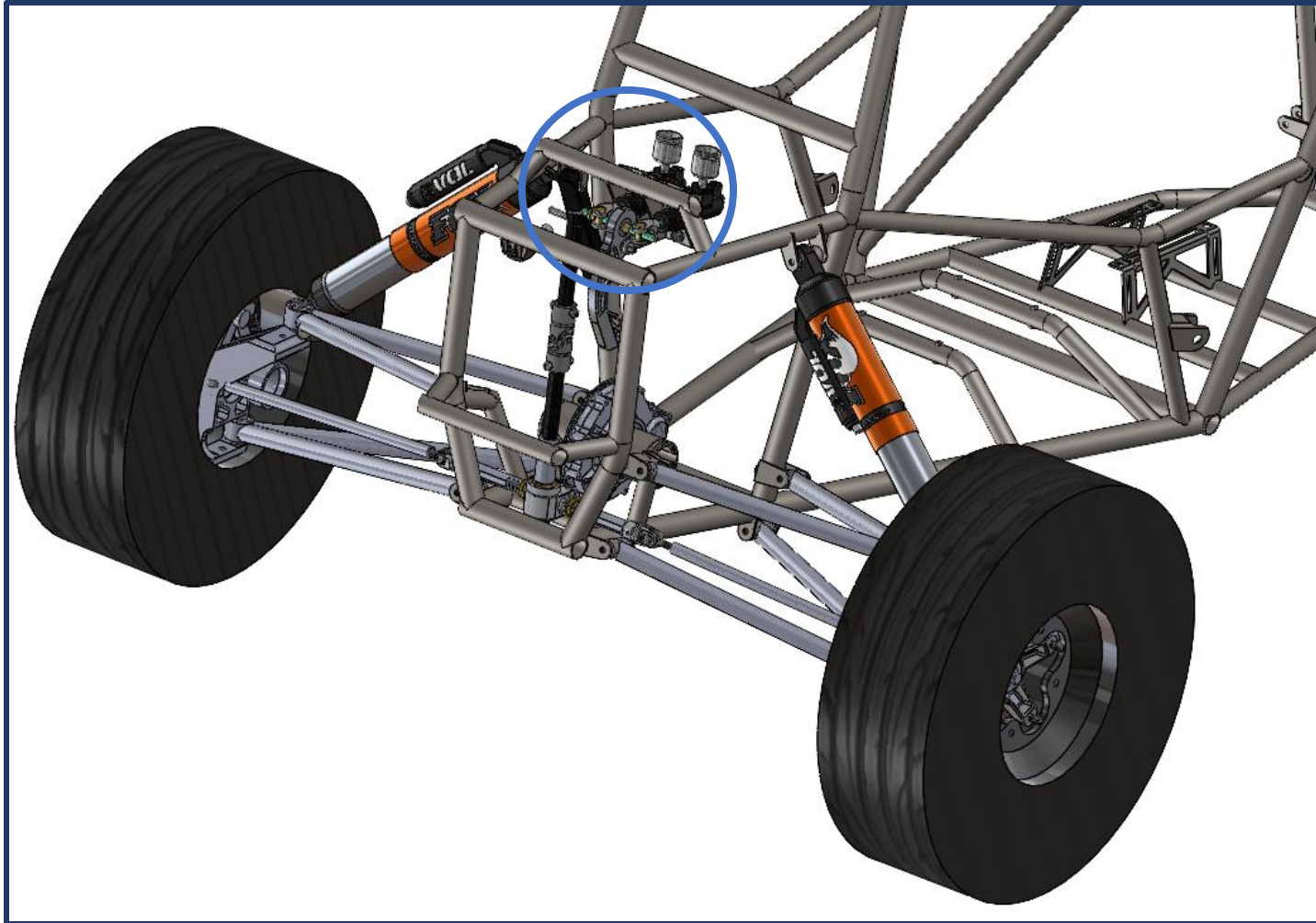

Front End “Zones”

1. Suspension
2. Steering
3. Brake/Throttle

Design Efforts – Simplified CAD

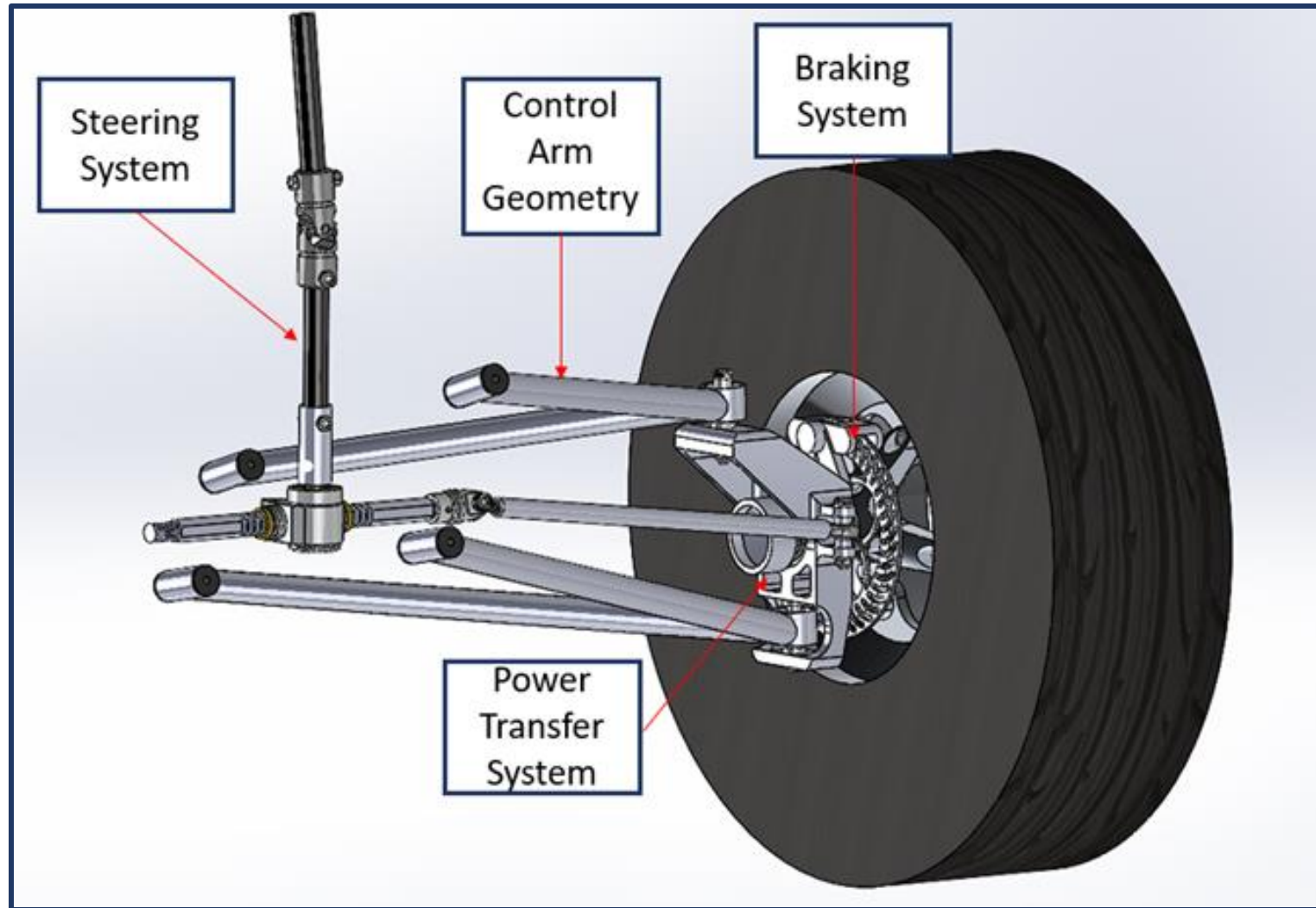

Design Efforts – Master Cyl & Pedal

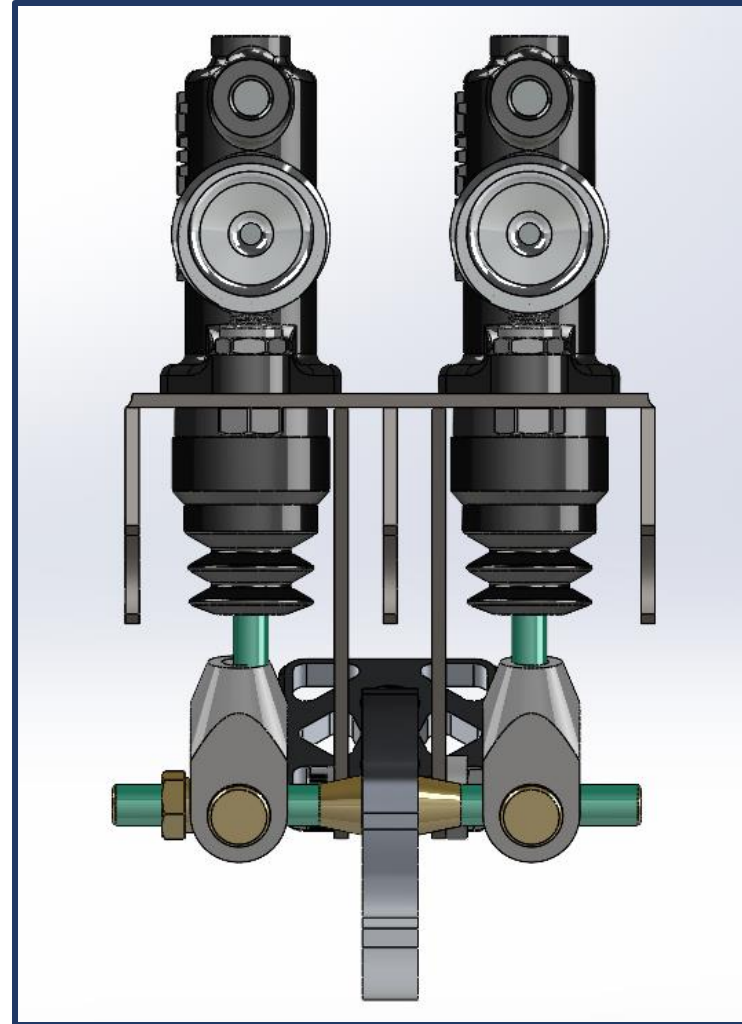
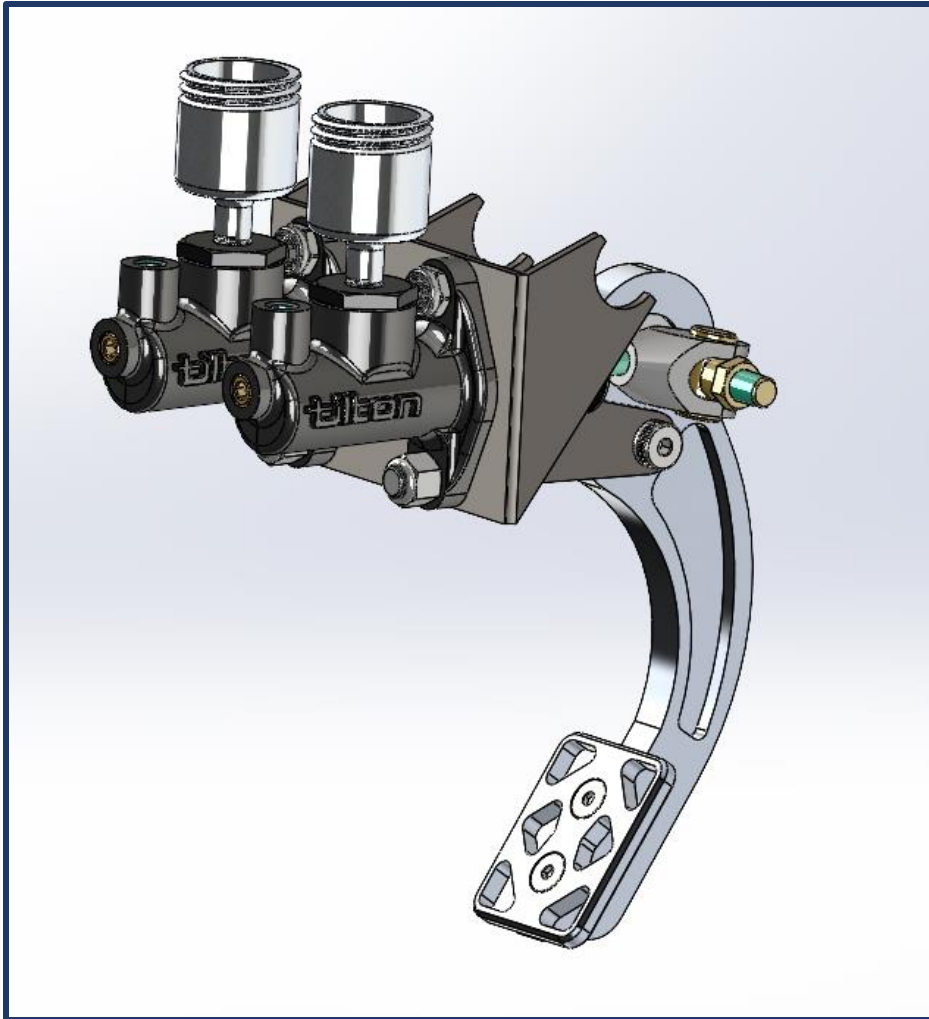

Purchasing Plan - Suspension

Classification	Part Name	Quantity	Cost	Total Cost	Material	Purchase/Made	Vender	Vender Part Number
Suspension	CV Axle/Nut	2	108	216	Steel	Purchased	Amazon	YFM350FGI
Suspension	CV Spline	2	40	80	Steel	Purchased	Amazon	Yfm350ba
Suspension	CV Bearing	4	72.92	291.68	Steel	Purchased	SKF	6006-2RS1
Suspension	Control Arm Swivel Joint	4	68.21	272.84	Steel	Purchased	McMaster Carr	63195K36
Suspension	Upper Control Arm Tabs	4	0	0	Steel	Purchased	Vroom	N/A

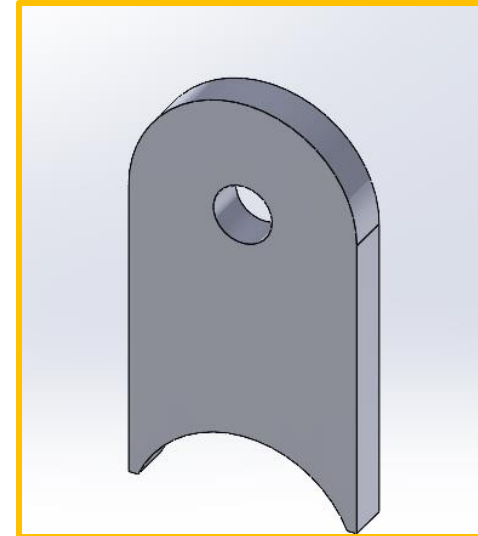

Purchasing Plan - Steering

Classification	Part Name	Quantity	Cost	Total Cost	Material	Purchase/Made	Vender	Vender Part Number
Steering	Rack End Set Screws	2	5	10	Aluminum	Purchased	Joes Racing Products	N/A
Steering	Pinion Housing	1	100	100	Aluminum	Purchased	Joes Racing Products	N/A
Steering	Pinion Gear	1	100	100	Steel	Purchased	Joes Racing Products	N/A
Steering	Pinion Bearing	2	10	20	N/A	Purchased	Joes Racing Products	N/A
Steering	3/8 Rod End for Tie Rod	4	10	40	Steel	Purchased	McMaster Carr	60645K14
Steering	Tie Rod	2	15	30	Carbon	Purchased	Amazon	N/A
Steering	Steering Column	3	15	45	Carbon	Purchased	Amazon	N/A
Steering	U Joint - ORDER ONE MORE	2	40	80	Steel	Purchased	McMaster Carr	6443K106
Steering	Pinion Face Plate	1	5	5	Plastic	Purchased	Joes Racing Products	N/A



Purchasing Plan – Throttle & Brake

Classification	Part Name	Quantity	Cost	Total Cost	Material	Purchase/Made	Vender	Vender Part Number
Brake	Brake Rotor	2	N/A	N/A	Steel	Purchased	Vroom	N/A
Brake	Master Cylinder	2	220	440	N/A	Purchased	Tilton	78-625
Brake	Brake Hose	2	18.4	36.8	Steel	Purchased	Amazon	N/A
Brake	Pedal Sensor	1	5	5	N/A	Purchased	Amazon	4012866
Throttle	Throttle Pedal Sensor	1	5	5	N/A	Purchased	Digikey	SW156-ND
Brake	Brake Bias Shaft	1	62.9	62.9	Steel	Purchased	Pitstop USA	TIL72-250
Brake	Bronze Bushing	7	10	70	Bronze	Purchased	MMC	6391K867 and 6391K625
Throttle	Throttle Pedal Tabs	4	0	0	Steel	Purchased	Vroom	N/A
Brake	Master Cylinder Tabs	1	0	0	Steel	Purchased	Vroom	N/A
Throttle	Throttle Pedal Stopper	1	10	0	Titanium	Purchased	Existing Stock	N/A

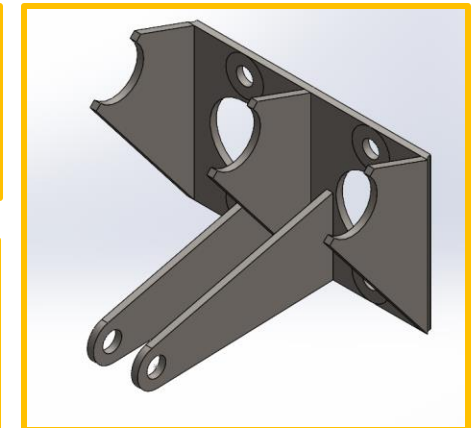
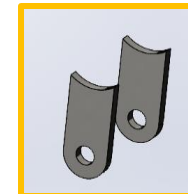
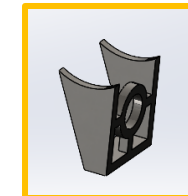
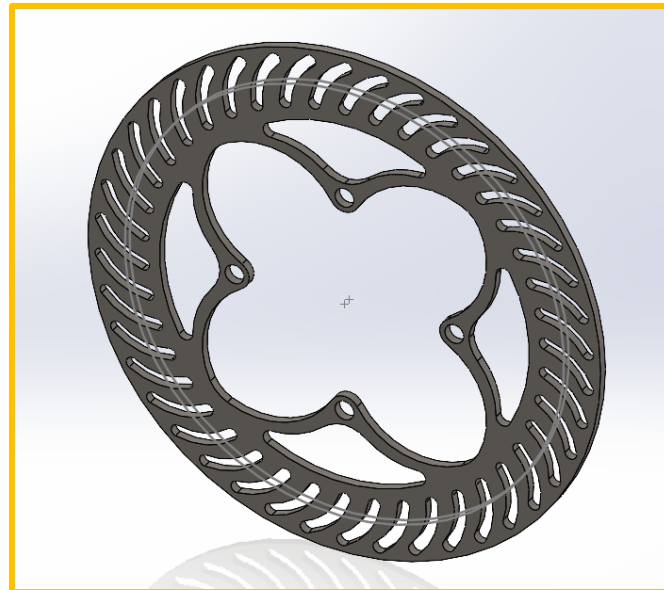

Purchasing Plan – Hardware

Hardware	Wheel Studs (25/pk), 3/8"x16, 1" Length, Button Head Bolt	8	0	0	Steel	Purchased	Copper State	N/A
Hardware	Brake Rotor Bolt (10/pk), 1/4"-20, 5/16" Length, Socket Head	8	0	0	Steel	Purchased	Copper State	N/A
Hardware	Brake Caliper Bolt, M8x1.25, 20mm length, Countersunk	4	0	0	Steel	Purchased	Copper State	N/A
Hardware	LCA Knuckle Shoulder Bolt, 1/4"-20, 1/4", 2" Length	2	0	0	Steel	Purchased	McMaster Carr	N/A
Hardware	TR Shoulder Bolt, 5/16"-18, 3/8", 1.5" Length	2	0	0	Steel	Purchased	Copper State	N/A
Hardware	TR/UCA Shoulder Bolt Nut (100/pk), Grade 8, 5/16"-18	15	0	0	Steel	Purchased	Copper State	N/A
Hardware	UCA Knuckle Shoulder Bolt, 5/16"-18, 3/8, 2.25" Length	2	0	0	Steel	Purchased	Copper State	N/A
Hardware	Control Arm Mount Bolt, 3/8" Shoulder, 2" length, 5/16-18"	8	0	0	Steel	Purchased	Copper State	N/A
Hardware	TR Rack Shoulder Bolt, 3/8", 5/16-18", 1.25" Length	2	0	0	Steel	Purchased	Copper State	N/A
Hardware	Rack Mount Bolts, 3/8"-16, 2" Length (10/pk)	2	0	0	Steel	Purchased	Copper State	N/A
Hardware	MC Bolt 3/8"-16, 7/8" Length	2	0	0	Steel	Purchased	Copper State	N/A
Hardware	MC Bolt 3/8"-16, 1" Length	2	0	0	Steel	Purchased	Copper State	N/A
Hardware	MC Nut, 3/8"-16 nut	2	0	0	Steel	Purchased	Copper State	N/A
Hardware	MC Nut 3/8"-16 Locnut, THIN (1/4" Max Height)	2	0	0	Steel	Purchased	Copper State	N/A
Hardware	Brake Pedal Shoulder Bolt, 3/8", 5/16"-18, 1" Length	1	0	0	Steel	Purchased	Copper State	N/A
Hardware	Brake Pedal CS Bolt, 1/4"-20, 1" Length	2	0	0	Steel	Purchased	Copper State	N/A



Copper State Bolt & Nut Co.

Purchasing Plan Percentages

Purchased

$$\frac{120 \text{ items}}{120 \text{ items}} = 100\%$$

On-Hand

$$\frac{116 \text{ items}}{120 \text{ items}} = 96.67\%$$

Manufacturing Plan - Suspension

Classification	Part Name	Quantity	Cost	Total Cost	Material	Purchase/Made	Vender	Vender Part Number	Man Hours Expended	Man Hours to Complete
Suspension	Upper Control Arm Tubes	2	8.8	105.6	4130, 4'	Made	IMS	N/A	44	44
Suspension	Lower Control Arm Tubes	2	8.8	105.6	4130, 4'	Made	IMS	N/A	44	44
Suspension	Control Arm Cups	4	0	0	Steel	Made	N/A	N/A	15	15
Suspension	Knuckle	2	450	900	6061-T6	Made	Ryan	N/A	40	80
Suspension	Hub	2	190	380	6061-T6	Made	Ryan	N/A	29	30
Suspension	Upper Swivel Joint Spacer	4	0	0	Steel	Made	Existing Stock	N/A	10	10
Suspension	Lower Swivel Joint Spacer	4	0	0	Steel	Made	Existing Stock	N/A	10	10
Suspension	Delrin Bushing	16	1.5	24	Delrin	Made	MMC	7521T16	4	4
Suspension	Upper Control Arm Shock Spacer	8	0	0	CF PETG	Made	N/A	N/A	4	4

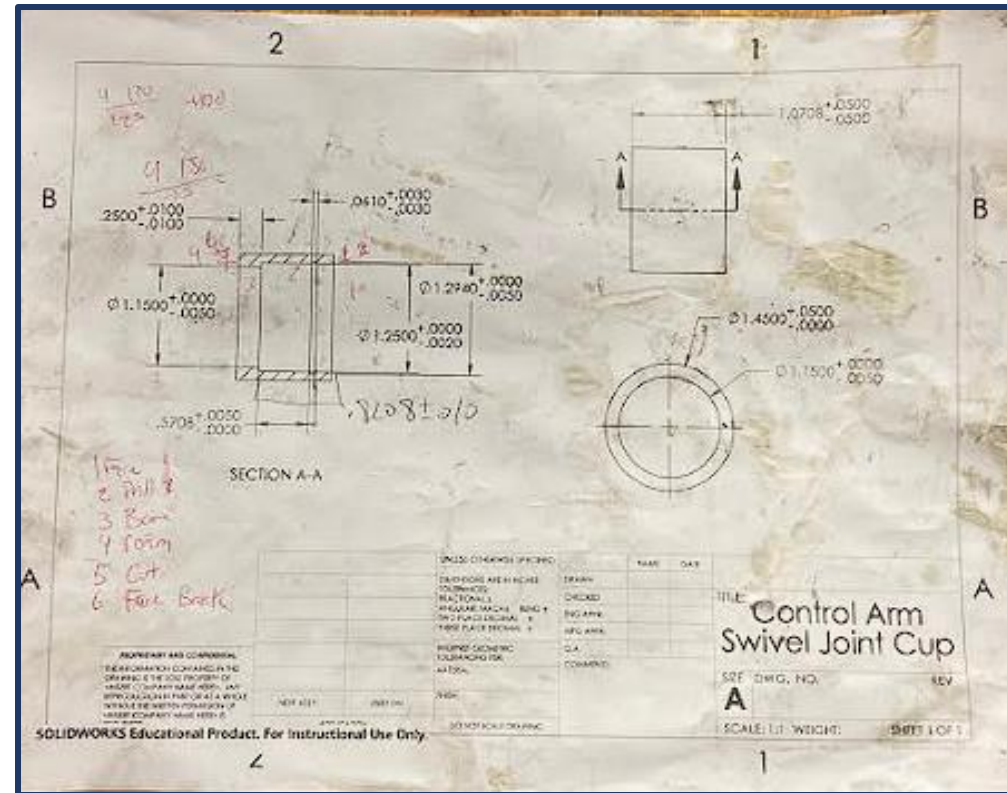
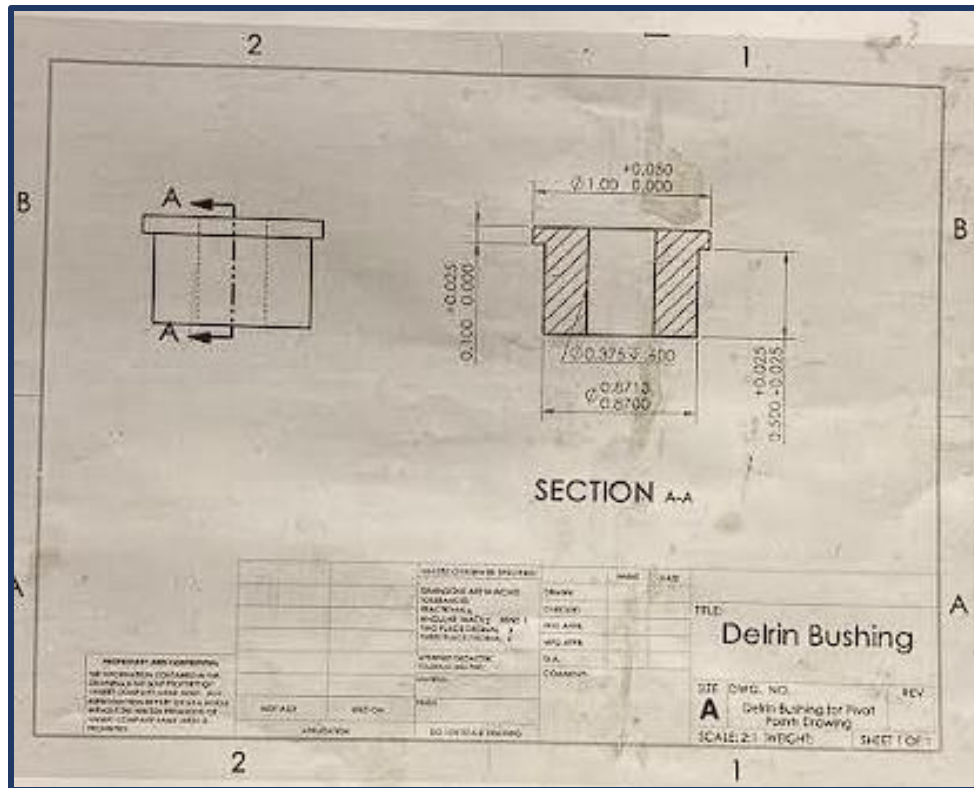

Manufacturing Plan - Suspension

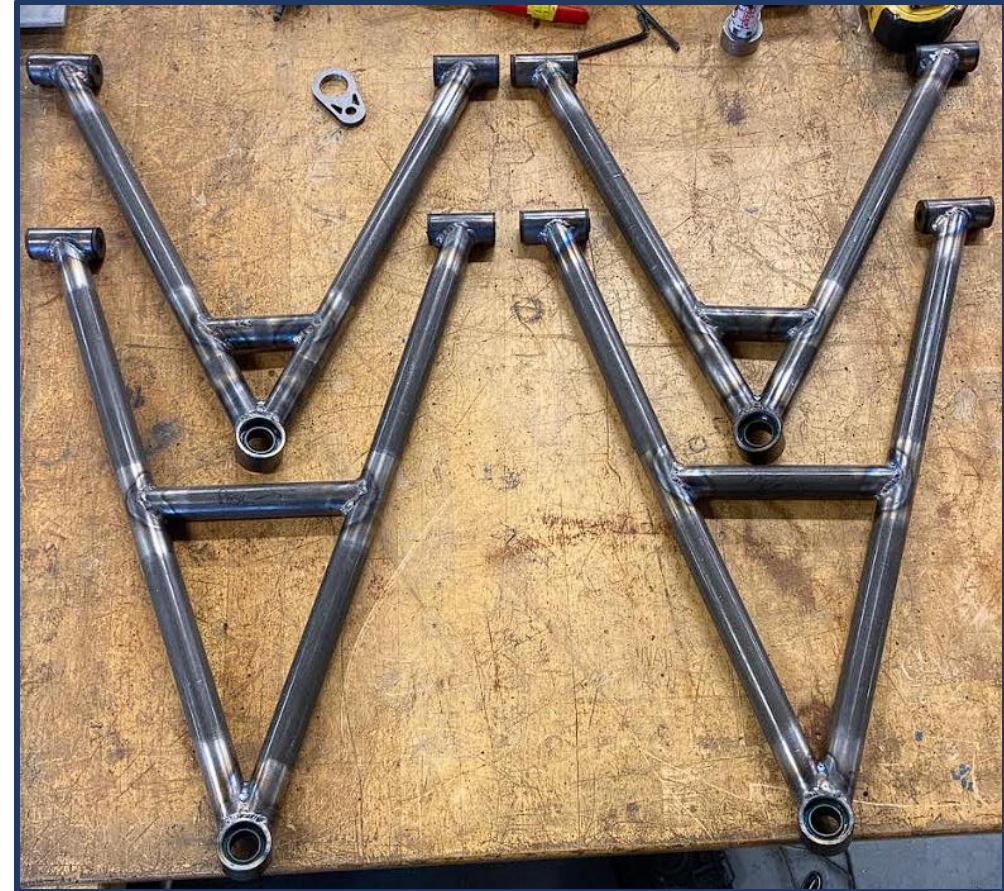
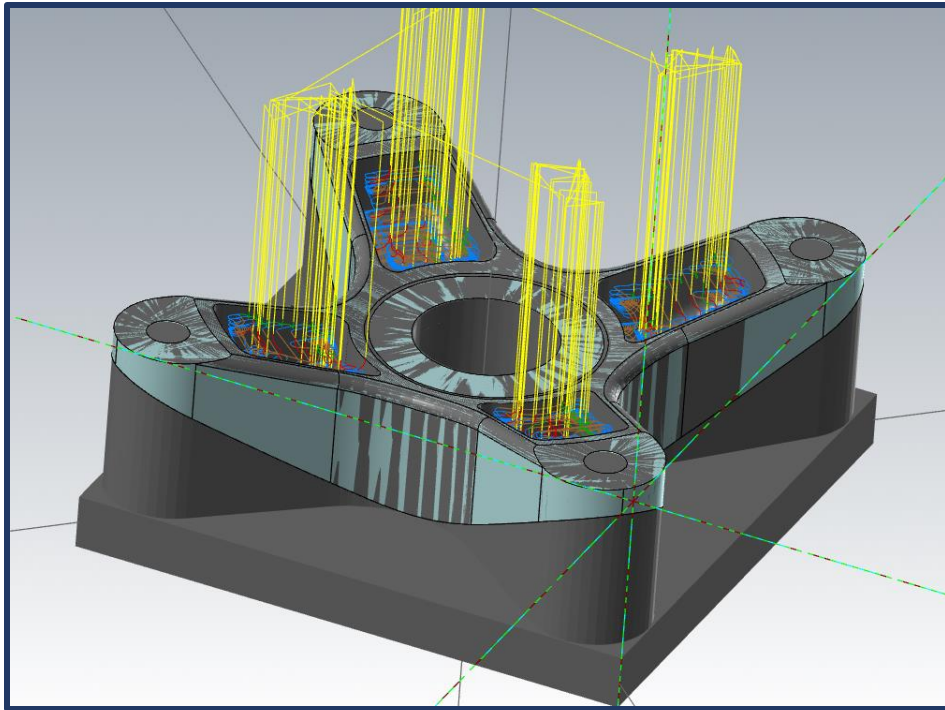

Manufacturing Plan - Suspension



Manufacturing Plan - Suspension

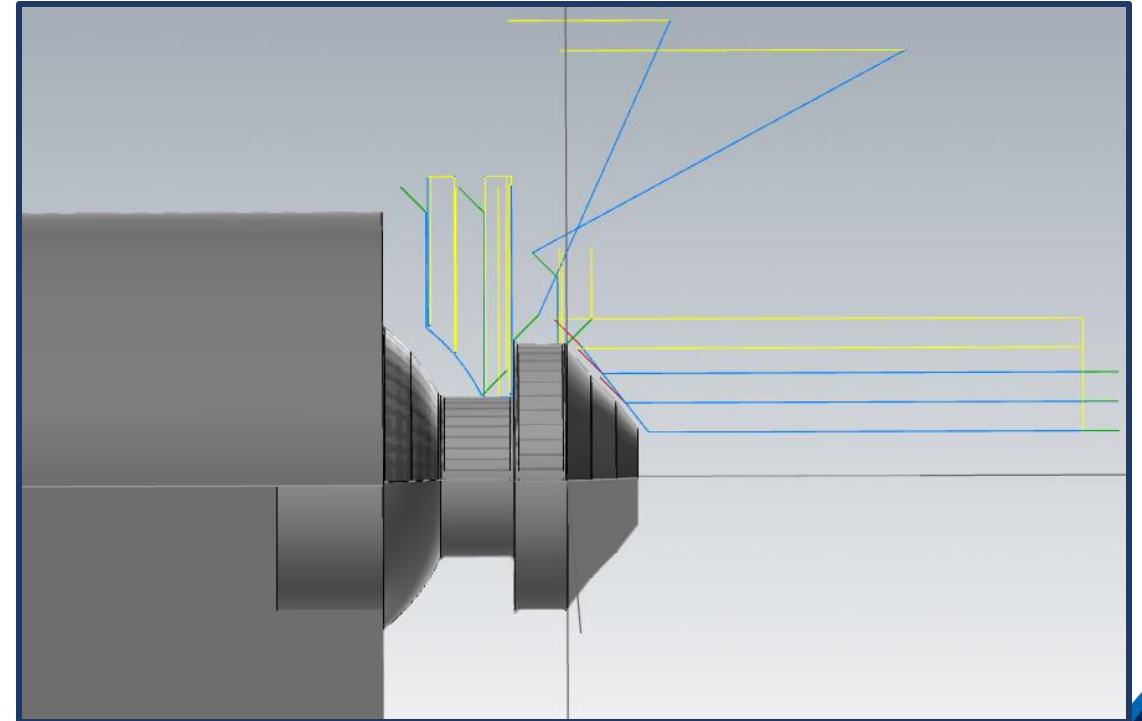
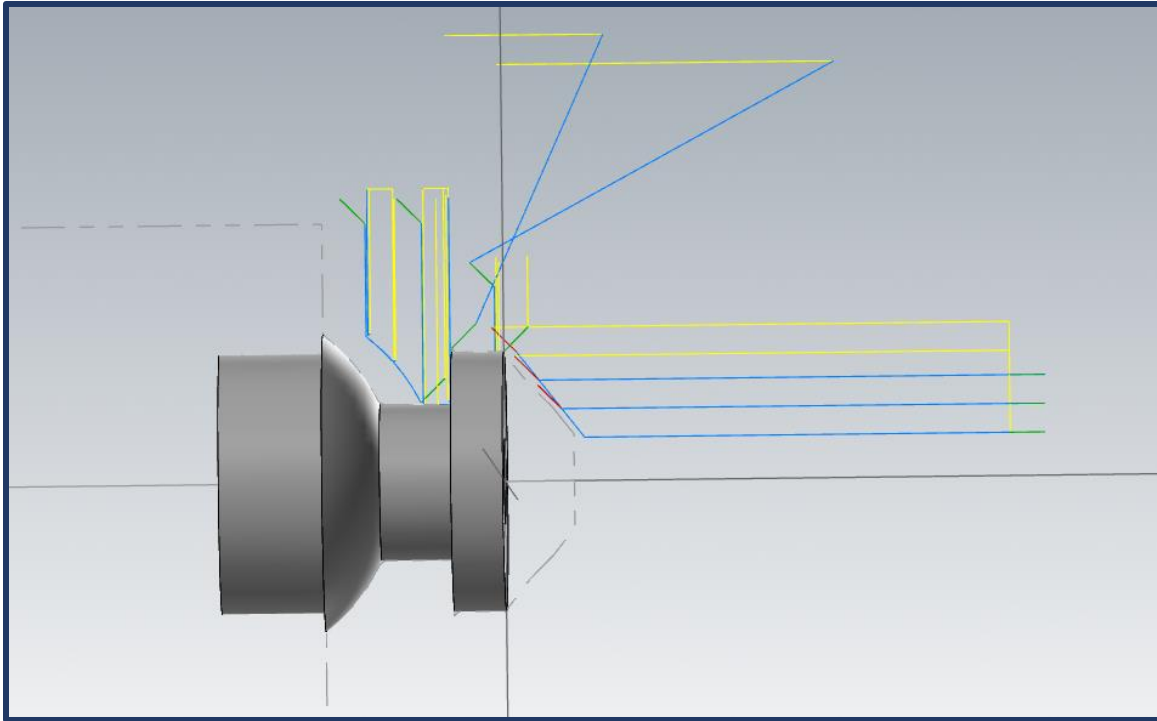

Manufacturing Plan - Steering

Classifier	Part Name	Quantity	Cost	Total Cost	Material	Purchase/Made	Vender	Vender Part Number	Man Hours Expended	Man Hours to Complete
Steering	Lower Knuckle Spacer	2	0	0	6061-T6	Made	Existing Stock	N/A	3	3
Steering	Steering Rack	1	0	0	Steel	Made	N/A	N/A	15	15
Steering	Rack End	2	10	20	Aluminum	Made	N/A	N/A	0	15
Steering	Steering Rack Support Sleeve	2	0	0	Aluminum	Made	Existing Stock	N/A	3	3
Steering	Steering Rack Support Sinter	4	20	80	Bronze	Made	MMC	N/A	4	4
Steering	Tie Rod Threaded Insert	4	0	0	Aluminum	Made	N/A	N/A	8	8
Steering	Steering Column Insert	4	0	0	Aluminum	Made	N/A	N/A	4	4
Steering	Steering Wheel	1	0	0	Carbon Plate	Made	Nova	N/A	5	10



Manufacturing Plan – Brake & Throttle

Classification	Part Name	Quantity	Cost	Total Cost	Material	Purchase/Made	Vender	Vender Part Number	Man Hours Expended	Man Hours to Complete
Brake	Brake Pedal	1	95	95	6061-T6	Made	Existing Stock	N/A	12	25
Throttle	Throttle Pedal	1	0	0	Carbon	Made	Bauer	N/A	2	2
Throttle	Throttle Pedal Spacer	1	0	0	Aluminum	Made	Existing Stock	N/A	2	2

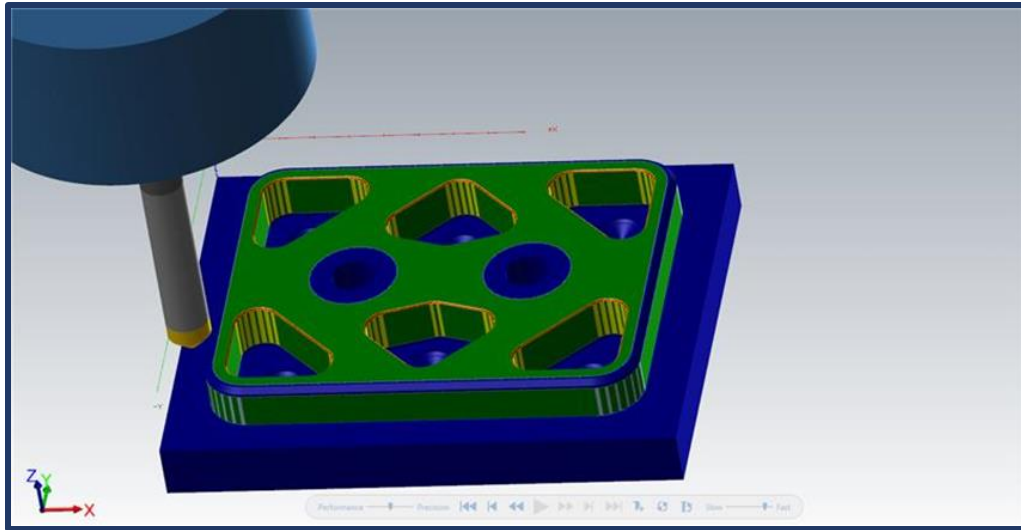

Manufacturing Plan - Percentages

Manufactured

$$\frac{258 \text{ hours}}{332 \text{ hours}} = 77.71\%$$

Project Demo (Cool Stuff)



Project Demo (Cool Stuff)



Gantt Chart Updates

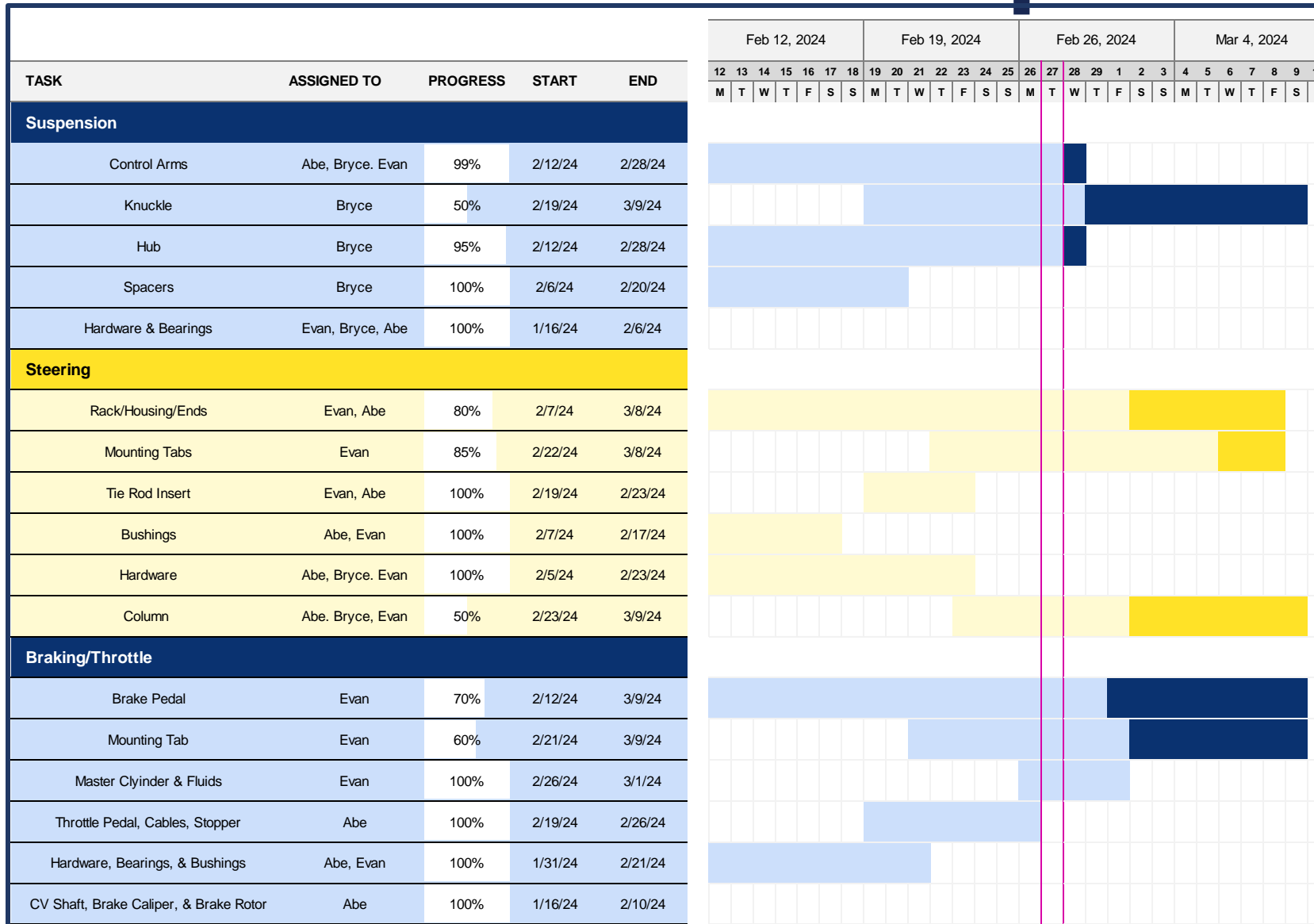

Current Status:
Mostly On-track

- Immediate Priorities:**
1. Finish op 2 of hub
 2. Finalize Knuckle CAM and get Haas running
 3. Turn down splines for hub
 4. Weld tabs and start assembling