

Robotic Ankle Exoskeleton

Conceptual Design Report

Diego Avila

Test Engineer & CAD Engineer

Emma De Korte

Project Manager & Logistics Manager

Tre Green

Financial Manager & Manufacturing Engineer

Fall 2023-Spring 2024

**NORTHERN
ARIZONA
UNIVERSITY**



Project Sponsor: NAU Biomechatronics Lab and Gore

Faculty Advisor: Dr. Zach Lerner

Instructor: David Willy

DISCLAIMER

This report was prepared by students as part of a university course requirement. While considerable effort has been put into the project, it is not the work of licensed engineers and has not undergone the extensive verification that is common in the profession. The information, data, conclusions, and content of this report should not be relied on or utilized without thorough, independent testing and verification. University faculty members may have been associated with this project as advisors, sponsors, or course instructors, but as such they are not responsible for the accuracy of results or conclusions.

EXECUTIVE SUMMARY

This report goes through the beginning process of creating a Robotic Ankle Exoskeleton. This project is focused on reiterating portions of a previous design created during the 2021-2022 academic year with help from the NAU Biomechatronics lab. Our team is specifically focusing on the chain system and overall bracket design. The design change includes changing from a sprocket to gear pulley to a sprocket to cable pulley and updating the bracket design to improve the overall strength of the design. To the date the team has designed the new bracket design and completed calculations to determine the best design to prototype moving forward. The calculations specifically made include determining the force that will act on the skeleton design, the forces on the attachment point, the torque acting on the ankle, tension within the cable on the cable pulley, the thickness of the footplate, forces acting on the various bracket designs, forces acting on the gear teeth, the cost of CNCing the bracket if the team went with that method and an analysis of the reaction forces. The team has determined the bracket design to prototype moving forward from the calculations completed and a prototype was made from that bracket design. The team went through a FMEA to determine where the design might fail and how to help mitigate the failures. Lastly, a schedule and a Bill of Materials was created to keep the team on track with the project and to see how much on unit would cost to manufacture. The report goes into specific details for each portion mentioned above.

TABLE OF CONTENTS

Contents

DISCLAIMER.....	1
EXECUTIVE SUMMARY	2
TABLE OF CONTENTS.....	3
1 BACKGROUND.....	1
1.1 Project Description.....	1
1.2 Deliverables.....	1
1.3 Success Metrics.....	2
2 REQUIREMENTS	3
2.1 Customer Requirements (CRs).....	3
2.2 Engineering Requirements (ERs).....	3
2.3 House of Quality (HoQ).....	4
3 Research Within Your Design Space.....	6
3.1 Benchmarking	6
3.2 Literature Review.....	8
3.2.1 Diego Avila.....	8
3.2.2 Emma De Korte	10
3.2.3 <i>Joscelyn Green</i>	12
3.3 Mathematical Modeling	14
3.3.1 <i>Torque in Cables – Diego Avila</i>	14
3.3.2 <i>Ideal cross section – Diego Avila</i>	15
3.3.3 <i>Material Properties and Thickness of the Footplate – Emma De Korte</i>	15
3.3.4 <i>Force Acting on Bracket Designs – Emma De Korte</i>	16
3.3.5 <i>Torque acting on Achilles Tendon – Joscelyn Green</i>	17
3.3.6 <i>Shear Force at Attachment Point – Joscelyn Green</i>	18
4 <i>Design Concepts</i>	20
4.1 Functional Decomposition	20
4.2 Concept Generation.....	21
4.3 Selection Criteria.....	23
4.4 Concept Selection.....	24
5 <i>Schedule and Budget</i>	26
5.1 Schedule	26
5.2 Budget	27
5.3 Bill of Materials (BoM).....	27
6 <i>Design Validation and Initial Prototyping</i>	29
6.1 Failure Modes and Effects Analysis (FMEA)	29
6.1.1 <i>Potential Critical Failure 1: Motor mount Bracket Failure</i>	30
6.1.2 <i>Potential Critical Failure 2: Screw Shearing</i>	30
6.1.3 <i>Potential Critical Failure 3: Rod Failure</i>	30
6.1.4 <i>Potential Critical Failure 4: Sprocket Failure</i>	30
6.1.5 <i>Potential Critical Failure 5: Chain Failure</i>	30
6.1.6 <i>Potential Critical Failure 6: Pulley Gear Failure</i>	30
6.1.7 <i>Potential Critical Failure 7: Pulley Wire Failure</i>	31
6.1.8 <i>Potential Critical Failure 8: Foot Plate Failure</i>	31
6.1.9 <i>Potential Critical Failure 9: Bearing Failure</i>	31
6.1.10 <i>Potential Critical Failure 10: Motor failure</i>	31
6.1.11 <i>Potential Critical Failure 11: Calf Cuff Failure</i>	31
6.1.12 <i>Potential Critical Failure 12: Pulley Wire Clamps Failure</i>	31

6.2	Initial Prototyping	32
6.3	Other Engineering Calculations	32
6.3.1	Variable Analysis of Support Reactions – Diego Avila	32
6.3.2	Calculating the cost for the bracket to be CNCed – Emma De Korte	33
6.3.3	Calculating Force acting on the teeth of the sprocket - Joscelyn Green.....	34
6.4	Future Testing Potential.....	34
7	<i>CONCLUSIONS</i>	35
8	<i>REFERENCES</i>	36
9	<i>APPENDICES</i>	41
9.1	Appendix A: Gantt Chart.....	41

1 BACKGROUND

Given the general description of the defined project and the previous approach taken to solve the engineering problem, this team has developed a new approach to improve aspects of previous designs. The ultimate goal is to build upon previous iterations in order to improve the walking gait of people who have cerebral palsy by decreasing the amount of biomechanical torque that their body has to produce at the ankle through mechanical assistance. The group that would benefit from this project is expected to be small because the exoskeleton is still in early development stages. Further research and development should produce an exoskeleton that is practical and affordable for everyone diagnosed with Cerebral Palsy. The overview of completed deliverables and the expected steps going forward are stated in the following subsections, including the budget and future goals for fundraising.

1.1 *Project Description*

This team worked in cooperation with Professor Zachary Lerner at NAU's Biomechatronics lab to develop an ankle exoskeleton to aid the walking motion and help improve the mobility of our clients with Cerebral Palsy. Our focus is primarily on the physical structure of the design, and not so much on the motor or sensor inputs. The previous trial “did not observe a significant group-level benefit relative to walking without the device. However, [they] did observe a marked benefit for [their] more impaired participants” [1] We intend to reiterate parts of their design, such as the bracket and pulley system. However, we are integrating a cable to chain system to avoid slippage. Through our development and cooperation with Dr. Lerner, we have developed a new bracket design, and are now completing a CAD model. The entirety of our project needs to remain under \$4,000, including all testing and prototypes. In addition, the team has to raise \$400.00 in additional funds for the project.

1.2 *Deliverables*

The deliverables completed so far have been calculations based on:

- Torque experienced by the Achilles Tendon
- Gear ratios and force output
- Selection of a material for the bracket that has appropriate properties to withstand the applied torque and bending force
- Geometry of bracket (last one sheared)
- Cross sections of members
- Type of fasteners
- Cable Tension

Each of these deliverables validates our approach to answering our engineering problem and

provides metrics to use in comparing methods/designs. The deliverables that need to be completed moving forward are finalizing the second prototype and setting a schedule for next semester. Each member of the team will then choose an aspect of the design to analyze and justify/explain its validity in a report memo.

1.3 Success Metrics

Most design metrics for this project are not going to be based on pass/fail, but whether it improves the torque output at the ankle from previous trials. Currently, there are no numerical metrics because our focus is on designing a bracket that can withstand the applied shear forces. Our design is expected to complete the same tests that the previous group did, including:

- Assembly time
- Weight Requirements
- Time to take on/off
- Torque Output
- Performance
- Terrain accessibility
- Client feedback

As a conclusion to the project, we will be expected to monitor a client as they test our design and analyze the output feedback that we receive from the motor and pressure plate sensors. This will be the most important test as it validates our design or gives crucial feedback on what needs to be improved upon in the next iteration.

2 REQUIREMENTS

This section will discuss the requirements that were given to us by our customer regarding what he wants to see in our final product. Using these customer requirements, we then quantified these requirements to give us engineering requirements. Which gives us quantifiable values which our product needs to meet to be able to be considered a success. Then using these two requirements we then created a house of quality, which will explain the correlation between the customer requirements and the engineering requirements. Then the house of quality also shows the weight of each requirement. These weights show how important each requirement is to the customer. Using this house of quality will allow us to create an effective design that will meet each criterion, while also allowing us to prioritize certain requirements over others.

2.1 Customer Requirements (CRs)

During our client meetings with Lerner, we discussed some of his requirements which he believes our product should meet. These customer requirements are listed below.

Lightweight

Agronomical- Human Centered Design

Durable

Economical or Cost Effective

Low profile- nonobtrusive to daily life

Have a chain to pulley system

One of the customer requirements that we were given is that the ankle exoskeleton needs to be lightweight. Because the primary users of this product will be people between the ages of 8-16 with cerebral palsy. So having a heavy exoskeleton will be very advantageous for the user. The second requirement is that it needs to be agronomical. Having a human-centered design will allow the user to easily put on and remove our product. The third requirement is it needs to be durable. Meaning that our design needs to be able to last for multiple uses. The fourth requirement is that our product needs to be economical. So, we need to keep our costs for the product as low as possible without compromising on the quality. The second to last requirement is that our design needs to be low profile. So that our product doesn't unnecessarily protrude from the ankle or cause a hinderance to the user during their daily life. The last customer requirement is that the actuating system for our exoskeleton must use a chain to pulley system.

2.2 Engineering Requirements (ERs)

The following deliverables are our constraints moving forward:

-\$4,000.00 budget

- Range of motion should be 45 degrees in either direction (resting is 90)
- Weight < 1 kg per leg
- Cannot extrude from the body more than 10 cm
- Lifetime of 100,000 steps
- Time to take on/off (<60 s)

There is a lot of creative room for the engineers on this project. Considering that biomechanics is a newer advancement, there are not many designs to reference. Because of this, we are working off of the previous team's progress and fixing aspects of that design. Through trial and error, Doctor Lerner has directed us to reposition the motor house onto the calf cuff and feed our pulley cables through the supporting bracket. This requirement doesn't necessarily have a quantitative result, but it is a requirement for our design.

2.3 House of Quality (HoQ)

After discussing the engineering requirements and customer requirements, a House of Quality (Figure 1) was created. A House of Quality is a visual way to see the correlation between the engineering requirements and customer requirements and is used to see how the team can improve the teams design to make it better than those already on the market.

Within the House of Quality, it includes the customer requirements and the weights of each requirement. This includes lightweight, easy to take on and off, durable, cost effective, and small in size or close to body. The team then weighted each requirement in terms of importance. The most important requirement was that it was cost effective to make, this is to ensure that the exoskeleton can be replicated for a cheap cost making it more accessible to the population. The second requirements include easy to take on and off and durable. This is to ensure our design can be put on and off by the user without assistance from a researcher or designer and that it lasts long enough for the device to be helpful. Lastly, lightweight and small in size were the least important, as if the design is slightly heavier or larger in size it might not be as big of an issue as the other requirements.

The customer requirements were then transformed into quantitative engineering requirements. Which include decreasing the weight, increasing the durability, decreasing the timing, decreasing the cost of each leg, and decreasing the protrusion from the body. Each requirement has a quantitative value attached to it, those are: each leg being less than 1kg, each leg lasting at least 100,000 steps, it taking less than one minute to take on and off, each leg being less than \$2,000, and each leg being less than 10cm from the body.

Each engineering requirement was then compared to each customer requirement stating whether it has a strong positive correlation (++), a positive correlation (+), a neutral (0), a negative correlation (-), or a strong negative correlation (--). Positive correlation means that if one requirement changes the other will also change in a positive way. Negative correlation means that

if one requirement changes the other will change in a negative way. A neutral correlation implies that if one changes the other won't change or it won't change in a positive or negative way. The team found that decreasing the protrusion from the body strongly positively correlates with decreasing weight. Decreasing the cost of each leg positively correlates to decreasing weight and decreasing the time it takes to remove the exoskeletons. Decreasing timing has a neutral correlation with decreasing weight. Decreasing the protrusion has a neutral correlation to increasing durability, decreasing timing, and decreasing the cost of each leg. Lastly, there was a negative durability between increasing durability and decreasing weight, as well as, increasing durability and decreasing the cost of each leg and decreasing timing.

After comparing each requirement, they are then compared to three different devices within the industry currently. Those are the Technaid Eobotic Ankle H3, Rewalk Restore Soft Robotic Exoskeleton, and the Untelthered Robotic Ankle Exoskeleton. Each specific design is explained in the benchmarking section. The team then ranked each design based on how we felt it stood up to the customer requirements. Finding that each design has excellent features, acceptable features, and poor features.

		Technical Requirements					Customer Opinion Survey				
		Decrease Weight	Increase Durability	Decrease Timing	Decrease Cost of Each Leg	Decrease Protrusion from Body	1 Poor	2	3 Acceptable	4	5 Excellent
1	Decrease Weight										
2	Increase Durability	-									
3	Decrease Timing		0	-							
4	Decrease Cost of Each Leg	+			+						
5	Decrease Protrusion From Body	++	0	0	0						
1	Lightweight	3	5	3	3	3	A				BC
2	Easy to take on and off	4	3	1	5	3		BC		A	
3	Durable	4	2	5	1	2			ABC		
4	Cost Effective	5	4	4	1	5					
5	Small in size, close to body	3	5	2	3	2	A	B		C	
Technical Requirement Units		kg	steps	min	dollars	cm					
Technical Requirement Targets		<1	100,000	<1	<2000	<10					
Absolute Technical Importance		19	15	13	15	13					
Relative Technical Importance		1	2	3	2	3					

Figure 1: House of Quality

3 Research Within Your Design Space

3.1 Benchmarking

For our benchmarking we decided to look at 3 different robotic exoskeletons to assist our team during our concept generation. Each of these products are an ankle exoskeleton device which is used to assist people with a variety of mobility disorders. We used each of these products to see how they attached their specific motor to the assembly and to compare our future designs to these products

The first product that will be looked at is the previous capstone project, which is shown below in Figure 2. The bracket design utilizes a tube which slides on to the rods and has two pieces which seem to be welded to the tube where the motor will be mounted at. This design would be lightweight as well as cheap since it can be machined from a single block of aluminum. But because of this design there was shearing that occurred on the bracket. So, by learning from the previous group's mistakes, our team will be able to design a better mounting bracket.



Figure 2: Fully Active Chain and Sprocket Ankle Exoskeleton for Rehabilitation Assistance

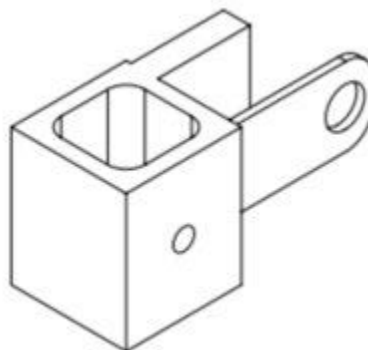

Figure 3: Bracket used on Fully Active Chain and Sprocket Ankle Exoskeleton for Rehabilitation

Assistance

The next product that was used during our benchmarking was the robotic ankle H3 by Technaid shown in Figure 4. Instead of having a motor mount attached to the top of the rod, the motor is placed directly at the ankle. This would allow for the removal of the gear and pulley system as well as reducing the amount of strain the bracket and rod will undergo. But the downside of having the motor placed at the ankle is that we would need to buy a stronger motor, since there would be a gear ratio to increase the force generated by the motor. But we can use the design for how the motor is attached to the ankle to better design our own product.



Figure 4: Robotic ankle exoskeleton H3

The last product which we researched during our bench marking is the ultra-lightweight and versatile untethered robotic ankle exoskeleton. This product uses the same gear to pulley system that our current model will use. But a big difference is that this device also uses Bowden cables, and the motor is also placed in a box which will be attached to the user's back. This device uses a rail type bracket to attach the motor to the assembly. This design could be useful if we designed this rail to fit over the rod or attach to the rod.

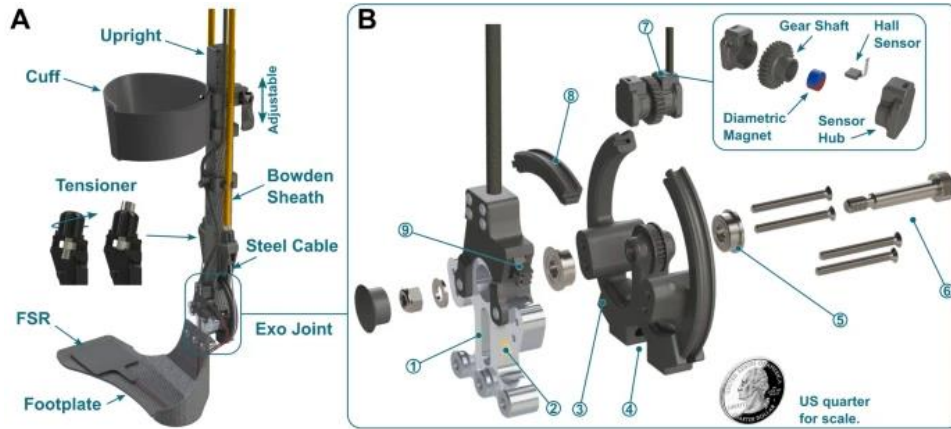

Figure 5: ultra-lightweight and versatile untethered robotic ankle exoskeleton

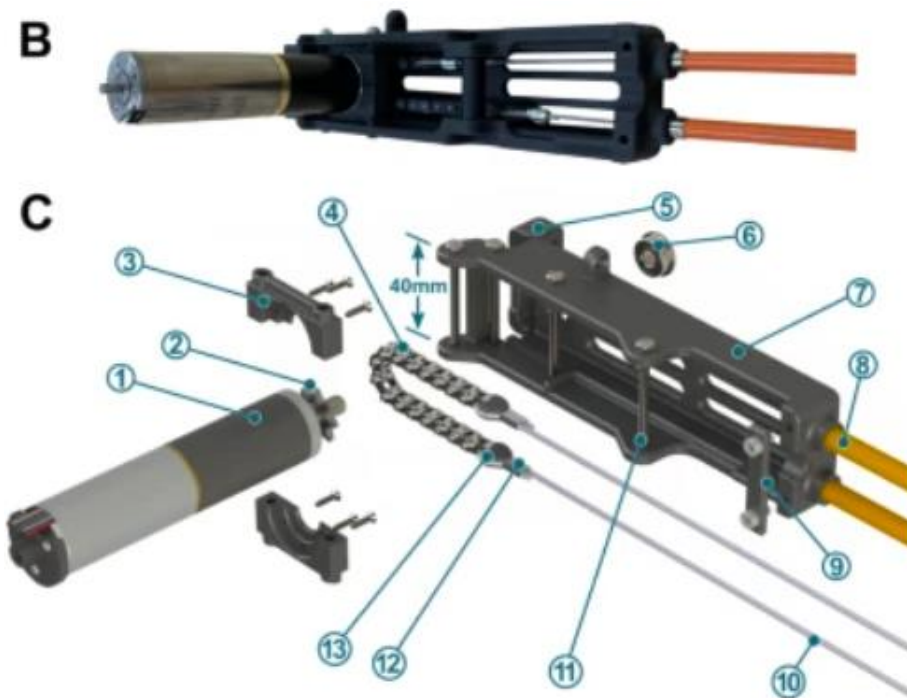

Figure 6: Bracket Mount for ultra-lightweight and versatile untethered robotic ankle exoskeleton

3.2 Literature Review

3.2.1 Diego Avila

Before designing the full exoskeleton, it was necessary to simplify the general design problem and calculate the torque acting on the human body. The following references provide equations and theorems that helped the team approach the problem and decide the best way to maximize biomechanical output and efficiency.

Mechanics of Materials[6]

The Mechanics of Materials textbook encompasses the introduction knowledge necessary to understand the reactionary forces from the contact of gears and gear train ratios. It was necessary to further understand torque and how it translates through gear trains.

Gear Ratio[7]

This pdf is a study guide developed by Professor Joel Kammet that covers the basic formulas for relating gear diameter and force to torque. It defines gear train ratios and the output speed and torque that results. This further develops the teams ability to decide the input necessary that would be able to have an output that can assist the walking motion.

Gear Train Ratio[8]

This article delves further into gear train ratio and provides real life application examples that utilize gears. A 1:1 gear ratio is not ideal for this project as it would require too much input torque to be a feasible application. In order to produce the necessary output power, it was beneficial for the team to analyze advanced applications of gear trains.

Fundamentals of Manufacturing[9]

The Fundamentals of Manufacturing textbook defines a process that the design team can reference when approaching the problem. An important aspect of designing biomechanical machines is identifying which manufacturing process best compliments biological structures. There are certain advantages of choosing the right development that work in favor of our project due to the fact that they affect the molecular structure of materials, reduce cost, or improve time efficiency.

The laboratory of Zach F. Lerner, Ph.D. [10]

Professor Dr Lerner has developed teams that consistently improve on previous approaches. Reported in detail on the NAU biomechatronics page is the complete process that the previous team took to improving the motor function of the ankle. By analyzing previous approaches through the engineering design process, it is possible to fix previous failures.

Gears in Nature [11]

It was very interesting to further understand how biological adaptations have developed gear systems within insects. In order to optimize power and synchronize its legs when jumping, some insects have gained an advantage in nature. Our objective is to mimic the efficiency of nature with our mechanical supplements.

Exoskeleton Expansion [12]

Researching the development of exoskeletons and the process of creating one greatly improves the insight for this challenge. Understanding the effects of how biomechatronics improves lifestyles because of user reviews is essential to learning how to improve performance of existing devices.

Opportunities and Challenges in the Development of Exoskeletons for Locomotive Assistance
[13]

A compilation of several approaches to the problem of decreasing the metabolic cost that walking takes. By understanding what approaches have been taken to solve this problem and recognizing that lower body exoskeletons are weight bearing devices benefits the development of further approaches.

Exoskeleton Makes Walking Faster, Less Tiring [14]

Exoskeletons benefit the mobility of people who have physical restrictions. However, physical models are not enough to account for the complexity of biological developments. Stanford researchers look into machine learning program to improve the synchronicity of machine enhancements with the natural movements of the user.

Characterization and Evaluation of Human-Exoskeleton Interaction Dynamics: A Review [15]

This article puts into perspective the other applications of biomechanical assistants. It helps differentiate between other robotic technologies and exoskeletons by clarifying that exoskeletons have a much more intrinsic interaction with human bodies. It increases the understanding the other mobilities that exoskeletons can improve, including spinal limitations and trauma related immobilities. Understanding how exoskeletons can be applied and the approaches used to account for the complexity of biomechanics improves the team's ability to account for inconsistencies in motion.

3.2.2 Emma De Korte

For the manufacturing process and overall design, it is important to understand the various materials and material properties available. The resources used below were publications from previous teams that have created exoskeletons as well as textbooks and websites that contain material properties. Below are the multiple resources I used.

Mechanics of Materials [22]

The *Mechanics of Materials* textbook was used to understand different materials and how they perform in different scenarios. This book goes through how to calculate material deformation, strain and stress, and how thick materials might need to be in order to have minimal deformation. This was used to help determine how thick our material should be in order to perform under the needed forces.

Materials Science and Engineering: An Introduction [23]

The *Materials Science and Engineering: An Introduction* textbook goes into detail on various material properties and how they are made up. It also discusses the yield and ultimate strength of various properties and at what point the material might fail. This was specifically used to learn and

understand the different materials the team was looking at, how each material performs under stress, and to help determine the needed thickness of materials.

Design Optimization [19]

This publication discussed one team's experience with designing an ankle exoskeleton and what worked and did not work for them. They also went into detail on what materials they were considering and what material they decided to use and why. This publication was specifically used to determine what materials might be helpful to look into and which ones should be used to perform calculations.

Design of a Passive Gait-based Ankle-foot Exoskeleton [20]

This publication goes through a professional ankle exoskeleton design with more advanced capabilities than our design. Their design contains a self-adaptive capability, and the publication goes into detail on how those functions within their design. However, this was specifically used to look at different motor assemblies that might be helpful to utilize within our design.

Untethered Robotic Ankle Exoskeleton [21]

This publication is of a robotic ankle exoskeleton that our sponsor and client helped create. Therefore, this publication was utilized to see what our client might be looking for with our design as well as how they went through the process to create it. This publication also had a motor schematic that was used to see what parts go into motor assemblies and what materials each portion was created out of.

Material Selections [24]-[35]

These websites contain all the information needed when determining the best material to continue with in our design. This included Vickers hardness score, the ultimate tensile strength, yield tensile strength, the cost of each material, and the density. These values were then used to be compared to each other to determine the material that fit all requirements needed.

Guide to calculating speeds and feeds []

This website contains helpful information in order to calculate the needed speed and feed of a CNC machine. This was used in order to determine how fast a CNC machine might cut the needed material which was then utilized to calculate the cost.

Why flute count matters – in the loupe – machinist blog []

This website was used to determine what a flute was in a CNC machine and what is the common number of flutes used. This is important, as the number of flutes affects the speed and how the CNC machine works. Therefore allowing us to calculate the length of time the teams cut would take.

How much does CNC milling cost []

This website contained an equation used to determine how much most CNC might cost for the team to manufacture the bracket design. This was helped in determining the cost tied to manufacturing the final bracket for the final design.

3.2.3 *Joscelyn Green*

Before we can begin designing our ankle exoskeleton, we first need to understand how the body is used during walking. To get a better understanding of the anatomical system and what it takes to walk, I decided to do my literature review on the biomechanics of walking and the effects cerebral palsy has on the human body. Below are the 7 resources that I used to help us during our project.

Engineering mechanics: Dynamics [12]

This Engineering dynamics textbook was chosen, since understanding dynamics will be extremely useful during our calculations on the forces acting on the foot, ankle, and Achilles tendon during walking. This textbook goes over everything from how to calculate the forces acting on a moving object to the impact forces on an object. Which was very useful during my calculations of the torque acting on the Achilles during walking.

Biomechanics of Movement: The Science of Sports, Robotics, and Rehabilitation [13]

This textbook explains what biomechanics is and how sports affect it. Biomechanics is the science of the body and how ligaments, muscles, and tendons work together to create movement. Which is important since our ankle exoskeleton needs to be able to replicate these bodily functions. Which is why this book is so important for the design of our exoskeleton and our choice of actuating system.

Biomechanics of the ankle," Orthopedics and Trauma [14]

This journal explains in depth the biomechanics of the ankle and how it changes during running and walking. This journal also discusses the muscle involved with ankle stability Which is useful since it gives us information on the complete range of motion that the ankle follows during walking. Such information as the range of motion during walking is about 30° and increases as the movement becomes more strenuous.

Foot Biomechanics During Walking and Running. [15]

This is another journal that explains the biomechanics of the foot during walking and running. Which gives us information on the bending motion that occurs when you push off the balls of your feet during walking. Which is useful information during the calculation of the amount of force acting upon the Achilles tendon during walking. Which will help us during material selection of our pully system.

A REVIEW OF GAIT CYCLE AND ITS PARAMETERS, [16]

This journal helps to explain what a gait cycle is and what is involved during our gait cycle. A gait cycle is the cycle of walking from when the heel strikes the ground to shifting your body weight to the other side. This helps us understand how a person's body weight shifts during walking and

how long it takes someone to go through an entire gait cycle while walking.

What is cerebral palsy?[17]

This website was created by the CDC to explain what cerebral palsy is and its effects on the human body. Which are symptoms like floppy or rigid limbs and involuntary bodily motions. Which is extremely important since our robotic ankle exoskeleton is designed for people ages 16 and below with cerebral palsy. Which allows us to design our exoskeleton with their symptoms in mind.

Biomechanical and perceived differences between Overground and treadmill walking in children with cerebral palsy [18]

This research article discusses the effects of cerebral palsy in children while walking. This document also shows how different cerebral palsy diagnoses can affect a person's gait length and ankle dorsal flexion. Which is useful during our design process to help us make our ankle exoskeleton more accommodating to more people with different diagnosis of cerebral palsy.

Fully active chain and sprocket ankle exoskeleton for Rehabilitation Assistance [39]

This website is the capstone website of the previous team's project which we are currently iterating. This website has been extremely helpful with designing our device, since it gives us a reference for the dimensions of the device and gives ideas for purchasing parts. This website was also helpful when comparing our design since their bracket failed and we need to make sure that the same doesn't happen to our current design.

The laboratory of Zach F. Lerner, Ph.D.. [40]

This reference is the biomechatronic Lab website which our client is the head of. This website was helpful in giving inspiration for certain design choices. Such as giving our team the idea to use wire cable clamps to attach the pulley wire to the pulley. This website has also helped us design our pulley for our device.

Mercer University, Gear Stress and Selection [41]

This is a lecture created by a professor at Mercer university. This lecture goes over the gears and the stress on gear. This lecture was useful in calculating the stress acting on the teeth of the gear to help us select the material that the teeth will be made from. The equation that was taken from these slides to calculate the stress on the gear teeth is called the Lewis equation.

3.3 Mathematical Modeling

3.3.1 Torque in Cables – Diego Avila

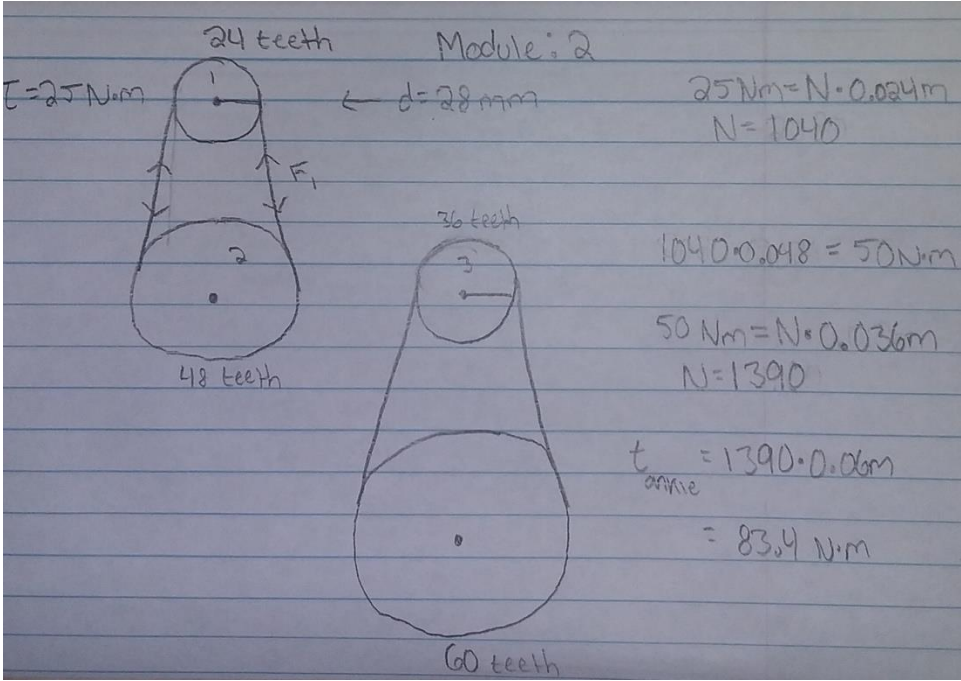

Figure 7: Gear train and tension in cables

A gear train is required for this project to be feasible. Two gears need a big size difference to produce enough torque to mimic the human ankle. As a result, gear trains are fundamental to approaching biological efficiencies and producing the necessary torque. The gear train ration is defined as Equation 1 and torque is defined as Equation 2.

$$\text{Gear Train Ratio} = \frac{\# \text{ of teeth in driven gear}}{\# \text{ of teeth in driver gear}} \tag{1}$$

$$T = F * D \tag{2}$$

3.3.2 Ideal cross section – Diego Avila

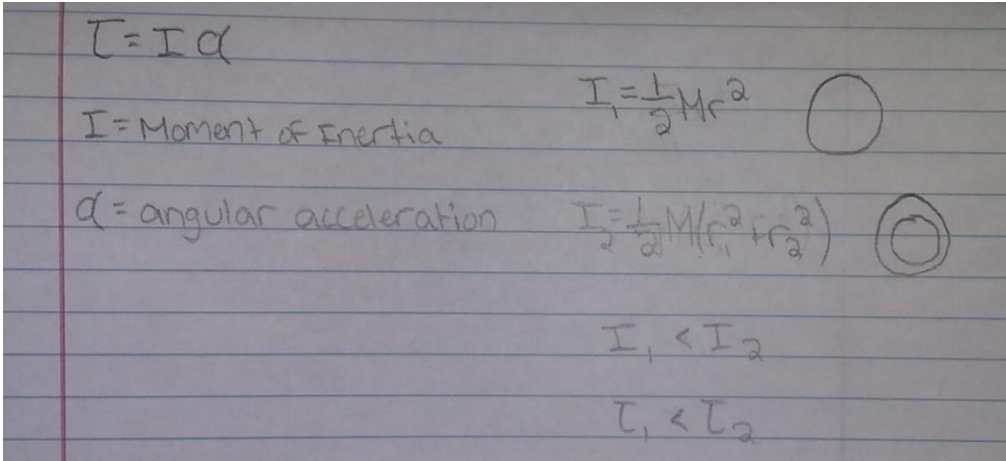

Figure 8: Calculations completed to determine the ideal cross section

The analysis of cross-sectional area was the first design development as that is where the last project sheared. To calculate moment of inertia of a solid circular cross section, Equation 3 is used, and for a hollow cross section, Equation 4 is used.

$$I = 0.5(\text{mass})(\text{radius})^2 \tag{3}$$

$$I = 0.5(\text{mass})((\text{outer radius})^2 * (\text{inner radius})^2) \tag{4}$$

3.3.3 Material Properties and Thickness of the Footplate – Emma De Korte

Each part of the motor assembly or ankle exoskeleton need to be made of a lightweight, strong material, and cost-effective material. In order to determine the best material to be used in the design, the team looked at four different materials, aluminum 6061-T6, low carbon steel, steel 4140, and titanium grade 5. All material properties used in determining the best material can be seen in Table 1.

Table 1: Material Properties [24]-[35]

Material	Hardness, Vickers	Ultimate Tensile	Yield Tensile	Density	Cost
Aluminum 6061-T6	107	310 MPa	276 MPa	2700 <i>kgm³</i>	\$4.67-\$252.94 (depends on thickness)
Low Carbon Steel	131	440 MPa	370 MPa	7850 <i>kgm³</i>	\$0.55 per kg
Steel 4140	207	655 MPa	415 MPa	7833 <i>kgm³</i>	\$0.55 per kg
Titanium Grade 5	349	950 MPa	880 MPa	4540 <i>kgm³</i>	\$50 per kg

--	--	--	--	--	--

From these properties, aluminum 6061-T6 was determined the best material to use as it is relatively lightweight, strong, and cost effective. Which match the customer requirements that need to be met.

Continuing with the design there is a footplate a part of the design. This will be provided by the client and is made of carbon fiber. However, the team wanted to determine the thickness that might be best for the success of the design. In order to determine the thickness, it is assumed an average 14-year-old male will best represent who will utilize the exoskeleton. This includes that mass, m, is 60kg, foot length is 24.45cm, foot width is 9.65cm, and the S=3.5 GPA or 3.5×10^9 Pa.

In calculating the thickness, the normal stress and acting force are needed to be calculated. Equation 5 calculated the normal stress, where F is the force exerted by the user and A is the surface area of the foot. Equation 6 calculates the force exerted by the user, where m is the mass, g is the gravitational acceleration, and μ is the friction coefficient of shoe against ground. The calculated force is 294N with the friction coefficient is 0.5.

$$\sigma = \frac{F}{A} \quad (5)$$

$$F = mg\mu \quad (6)$$

From the two above equations, the thickness can then be calculated using Equation 7. Where L is the length of the footplate or foot, S is the allowable stress of the material, and s is the normal stress. From the calculated values, it was calculated that the needed thickness is 8.7×10^{-4} mm. This value is very small, therefore the material used can be thin and will function under the conditions where the exoskeleton is used.

$$t = \sigma \frac{L}{S} \quad (7)$$

3.3.4 Force Acting on Bracket Designs – Emma De Korte

After coming up with four different designs of brackets that could be used. In order to determine the best design, it was important to perform a general force analysis to see which bracket might be best. In Figures 9-12, the four different designs analyzed can be seen.

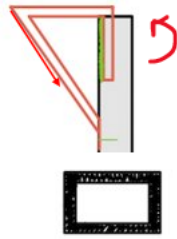

Figure 9: Design 1 Bracket and Cross-section

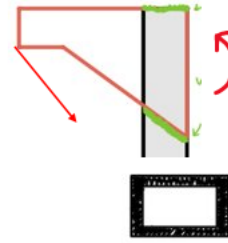

Figure 10: Design 2 Bracket and Cross-section

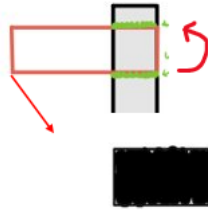

Figure 11: Design 3 Bracket and Cross-section

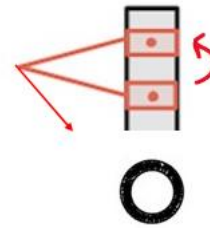

Figure 12: Design 4 Bracket and Cross-section

The forces calculated were the acting forces in the x-direction and y-direction. (Equation 8 & 9). The directional forces were calculated utilizing $F=388\text{N}$, which was calculated within the mathematical modeling below and assuming that the 388N of force were acting in a 45° angle from the cable pulling downward on the bracket.

$$F_x = 388\text{N}\cos(45^\circ) = 274.357\text{N} \quad (8)$$

$$F_y = 388\text{N}\cos(45^\circ) = 274.357\text{N} \quad (9)$$

With the calculated directional forces and assumptions made, it is assumed that the bracket with the highest surface area attached to the carbon fiber tubing will disperse the force better, making it the best option within the design.

3.3.5 Torque acting on Achilles Tendon – Joscelyn Green

This mathematical modeling is to calculate the amount of torque acting on the Achilles tendon during the walking motion. The first step is to create a free body, which can be seen in Figure 13 below.

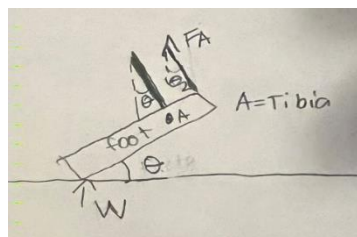

Figure 13: Free body Diagram of the Foot

Using this free body diagram, we can derive equation 1 to solve for the torque acting upon the Achilles tendon. The variables of equation 1 are W being the person's weight, which I used the average weight of a 14-year-old male. $D1$ being the distance from the balls of the feet to the tibia and $D2$ being the distance from the tibia to the Achilles. The variable θ being angle of elevation of the heel and θ_2 being the angle of the Achilles in relation to the tibia. The last variable is F_a which is the force of the Achilles. Using an ankle range of motion of $0-35^\circ$ and putting these variables into MATLAB, we get graph (Figure 14) that tells us that the max torque acting upon the Achilles tendon is equal to 47.3 NM. Which will help us in choosing a motor and during the material selection phase.

$$-W * D1 \cos(\theta) + F_a * D2 \cos(\theta_2) = 0 \tag{10}$$

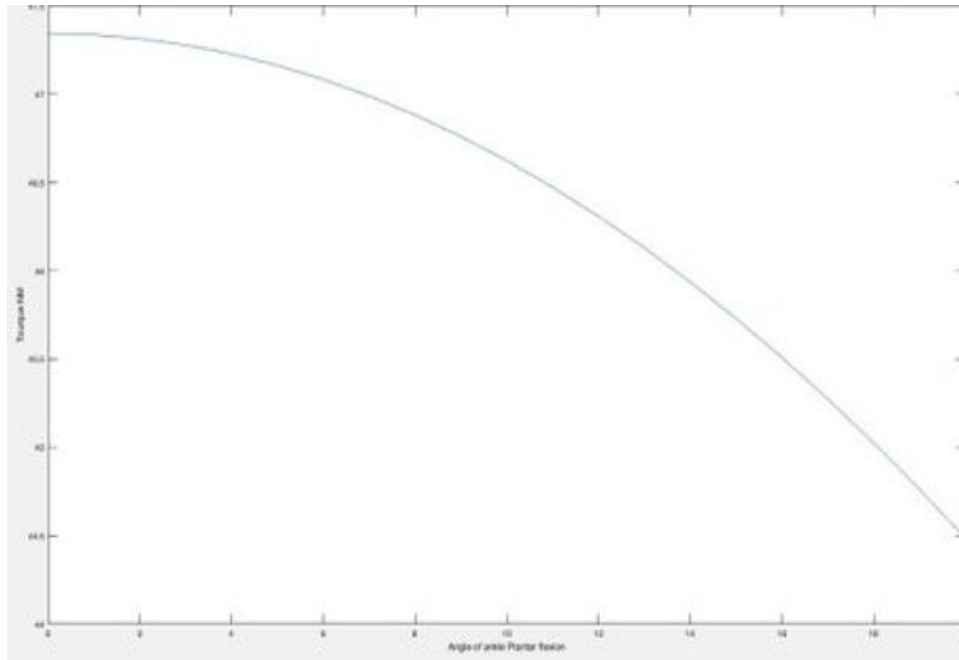

Figure 14: Graph of Angle of the ankle Vs Torque on Achilles Tendon

3.3.6 Shear Force at Attachment Point – Joscelyn Green

This mathematical modeling will investigate the best option of attachment method to use to attach our bracket to the rod. The first attachment method is using a bolt or rivet. Since these methods are very similar, we can use the same equation to calculate the shear force acting on them. To calculate the shear force acting on the bolt at the attachment point I used Equation 11. But before calculating the shear force, I first needed to find the force acting at that point. So, using Equation 12 with a torque value of 3.5, which was taken from the previous group's motor specifications and a gear radius of .009 m. I calculated a force of 388 N, but since the force isn't directly in the y direction, I had to use Equation 13 to find the force acting vertically at the connection point. Then using equation 2 with a factor of safety of 2 and bolt diameter of 9 mm, I calculated a shearing force of 8.61 N/mm² acting on the bolt. Which is well under the ultimate allowable stress of aluminum of 155 N/mm². Meaning that using a rivet or bolt is a viable option to attach our bracket.

$$\tau = FA \quad (11)$$

$$F = \text{torque} * \text{radius} \quad (12)$$

$$F_y = F \sin(45^\circ) \quad (13)$$

4 Design Concepts

4.1 Functional Decomposition

In order to better understand the design and functionality of an ankle exoskeleton the team created, and black box model and functional model were created. A black box model lays out the basic functional that needs to be performed by the device and then shows the material inputs/outputs, energy inputs/outputs, and the visual inputs/outputs.

The black box model for the robotic ankle exoskeleton is seen in Figure 15. The main function of the device is to assist in the walking cycle, also known as the gait cycle. The materialistic inputs are the foot, motor, and gears within the design, the outputs are the same. The energy inputs are biomedical or human energy, mechanical energy, and electrical energy. With the outputs being biomedical (human) energy, mechanical energy, electrical energy, and thermal energy. The energy inputs and outputs are from the human utilizing the design, and the motor and chain/cable system functioning. Lastly, there are no visual inputs, however the outputs are whatever the sensor detects.



Figure 15: Black Box Model

After the black box creation, a functional model was created to expand on the functionality and inputs and outputs. The functional model can be seen in Figure 16. This model includes the functionality of the motor, chain/cable system, the functionality of the foot, and the sensors. The red boxed section is where our team specifically is focused on. This is the motor and chain/cable system. The main function in this section is hold the motor, let the motor run, while the motor runs the gears and chain/cable rotates, then the pulley activates. This cycle continues the entire time the exoskeleton is being utilized. Within this section, there is the motor and gear as the materialistic inputs and outputs. Thermal, electrical, and mechanical inputs and outputs are the energy inputs/outputs. These come from the motor outputting heat as it functions, the motor itself creating electrical energy, and then the mechanical system working. There are no visual inputs or outputs in this section.

The other sections focus on the foot moving with the exoskeleton and the sensors working with the design. As the foot moves and walks the exoskeleton is experiences biomedical energy as the human is inputting their foot. The other section has the sensor as the material input with electrical energy as the input/output and the visual output being whatever the sensors detect. While the team isn't focused on this portion of the design specifically, it is still a part of the overall robotic ankle exoskeleton.

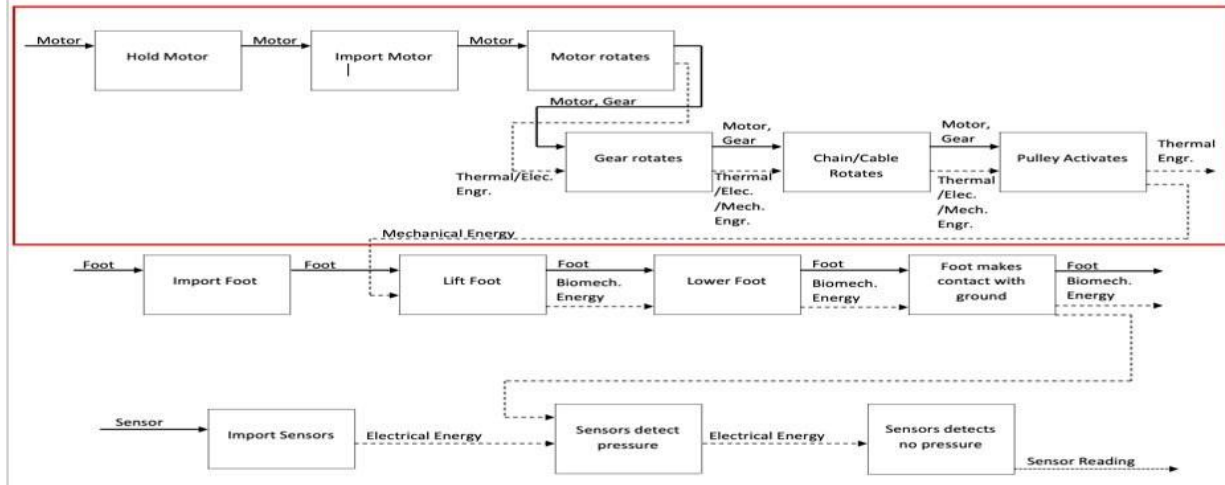

Figure 16: Functional Model

It is important to create the functional model and black box model as it helps the team better understand the overall design and how it should function. These designs tend to be created based on existing devices as the overall functionality is wanting to be replicated with improvements to the design.

4.2 Concept Generation

To begin our concept generation, we first need to split up our design into various subsystems. The subsystems that we came up with are the bracket design, the bracket cross section, and how the bracket will attach to the support bracket. Within these sub systems we came up with various ideas which we thought could be viable options. Listed below are the 3 subsystems, as well as our designs. Other things like the sprocket and pulley ratios, motor, gearbox, and all the electronics will be provided to us, which is why they were not added to the concept generation. Then to create our pulley system we planned on using clamps, which is the same method which Lerner has used on his previous projects.

The first subsystem that will be looked at is the bracket design, which can be seen in Figure 17 below. Design one has a triangular shape that will attach through the top of the rod, as well as attaching to the outside. The second design has a similar shape but does not attach to the inside of the rod and also completely wraps around the rod. The third design will also wrap around the rod,

but instead of a triangular shape it will have a rectangular shape. The fourth bracket design will have the same shape as the first design, but it does not attach to inside of the rod. Our last design will have two square collar brackets to attach to the rod, the bracket will also attach at one point and will branch out. These were the designs that our group came up with for how our actuating system will attach to the rod.

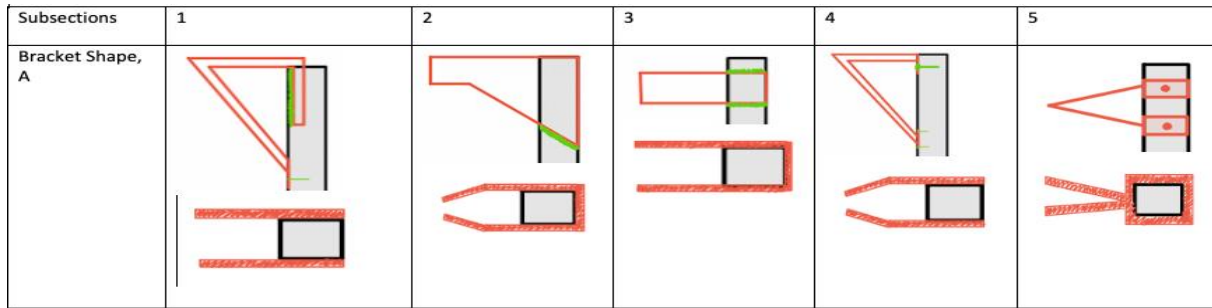

Figure 17: Geometry of Bracket Design

The second subsection that will be discussed is our cross-section designs, which can be seen in Figure 18 below. The first cross section design is the bracket having a circular and hollow cross section. The second cross section design is a rectangular hollow design. The last design we have for our bracket is a rectangular cross section that is hollow.

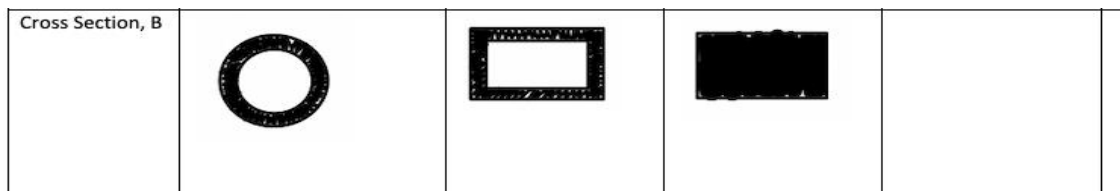

Figure 18: Cross section of Bracket members designs

The last design subsystem that we came up with is how the bracket will attach to the rod. These attachment type designs are shown in Figure 19 below. The first attachment type is using a rivet to attach the bracket to the carbon fiber rod. The second attachment type is using a bolt and hex nut to attach our bracket design. Then our last attachment type is using an epoxy to attach the bracket. Each attachment type has its own pros and cons, each will be explained during our selection criteria.

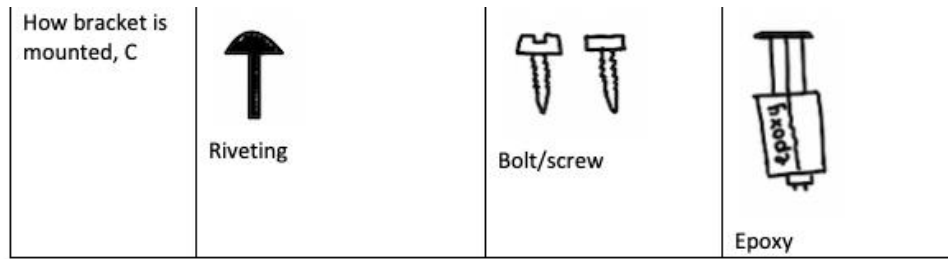

Figure 19: Attachment type designs

Then for materials selection of the bracket our team plans on using aluminum 6061, since this type of aluminum is very cost effective and lightweight. This material is also one of the easiest aluminums to machine as well as weld. Which is important since we plan on welding our bracket together to create the correct geometry.

4.3 Selection Criteria

The selection criteria for our design were the overall engineering requirements listed and discussed above. For this conception generation cycle, the team focused specifically on the bracket design as that was the root of the testing flaws in the previous design. However, one customer requirement was no longer applicable to these designs. That was that the design needed to decrease the timing it take to remove the device, this was no longer needed as the client specifically wanted the bracket to be mounted to the carbon fiber tubing.

To determine whether or not the design was lightweight, the team determined how much material would be needed to create the overall design based on the images drawn. The more surface area the design had, the more material it was going to need, and the material costs will be more, therefore being heavier overall. However, if a design was more intricate, the manufacturing process would cost more, but the design itself would be more lightweight. To also determine the design would be lightweight, the density of the specific material chosen will aid in that.

The durability of the design relied on the overall shape of the design, the material of the bracket, and how the bracket is attached. Every material will be made from the same material, therefore that point is not important, but the team did look through four different materials and their properties to determine the best one. These are discussed in the material selection mathematical modeling. However, to determine the best shape, a force analysis was carried out on each design. It was found that is the same general force is acting at a 45° angle downward on the bracket, that each bracket would have the same x-directional and y-directional forces. As well as each bracket would have a positive moment on the attachment point. Therefore, the area will best determine the shape of the design.

Lastly, the bracket should be small in size in order to make sure the items do not exceed the 10cm threshold. This was evaluated based on the general surface area of each bracket. While specific calculations were not made in this area, the team used the visual of each design to determine the

smallest area amount. This was able to be done, as each bracket was a different shape and not similar enough.

4.4 Concept Selection

To find the best design of the four created, a Pugh chart and decision matrix were created based on the selection criteria. The first round of concept selection was the Pugh chart, seen in Figure 20. A Pugh chart takes the design made by the team and compares them to a datum. Since the team is reiterating the previous design, the datum chosen was the bracket design from the previous team. Each design was then compared to the datum base on the selection criteria discussed above. The design was given a plus if it would the team felt it would perform better than the datum, a S if it would perform the same as the datum, and a negative if it would perform worse than the datum. These scores were given based on the mathematical calculations carried out and if the team felt it would do better, worse, or the same. After ranking each design, the total pluses, negatives, and same rankings were added up. Design 1 had three positives, and one same. Design 2 had two positives, one negative, and one same. Design 3 has four same. Design 4 has two positives and two same. The top two designs were then put into a decision matrix, these were Design 1 and Design 4.

Pugh Chart	Design 1	Design 2	Design 3	Design 4	Datum
Lightweight	+	+	S	+	datum
Easy to take on and off	N/A	N/A	N/A	N/A	Datum
Durable	+	+	S	S	Datum
Cost Effective	+	-	S	+	Datum
Small in Size, close to body	S	S	S	S	Datum
$\Sigma+$	#	2	0	2	Datum
$\Sigma-$	1	2	0	0	datum
ΣS	1	1	3	2	datum

Figure 20: Pugh Chart

The decision matrix (Figure 21) utilizes the same selection criteria as the Pugh chart. However, instead of ranking each design +, -, or S, they are given a ranking on a scale of one to ten. Each criterion is ranked on importance with the overall total being out of one or 100. The team gave light weight a score of 0.4, easy to take on and off, 0.05, durability, 0.3, cost effectiveness, 0.15, and small in size, 0.1. After each design was given a ranking one thru ten, the weighted score is calculated. Design 1 received an overall score of 8.55 and Design 4 received an overall score of 8.5.

Criteria	Weight	Design (1)		Design (4)	
		Score (1-10)	Weighted Score	Score (1-10)	Weighted Score
Light Weight	0.4	9	3.6	8	3.2
Easily taken on and off	0.05	10	0.5	10	0.5
Durable	0.3	8	2.4	9	2.7
Cost effective	0.15	9	1.35	8	1.2
Small in size	0.1	7	0.7	9	0.9
Total	1		8.55		8.5

Figure 21: Decision Matrix

Since Design 1 had the highest score, the team modeled that bracket design within SolidWorks. That is seen in Figure 22. This design utilized a triangular shape where it attaches in the carbon fiber tubing up top and bolted into the tubing on the bottom. With a rectangular hollow cross-section.



Figure 22: CAD model of the final bracket design; Design 1

5 Schedule and Budget

5.1 Schedule

In Figure 23, a portion of the Gantt chart utilized for semester 1 can be seen. This full Gantt chart can be viewed in Appendix A. The Gantt chart was used to plan out the various projects within the semester. Our team created the chart for Presentation 1, Presentation 2, Presentation 3, and Report 1. The remaining projects were the prototyping, which the team worked on together, and Report 2. For each project piece, different tasks were assigned to different people of the team, and then determined when the task should be started and completed. This was to ensure all items were completed on time.

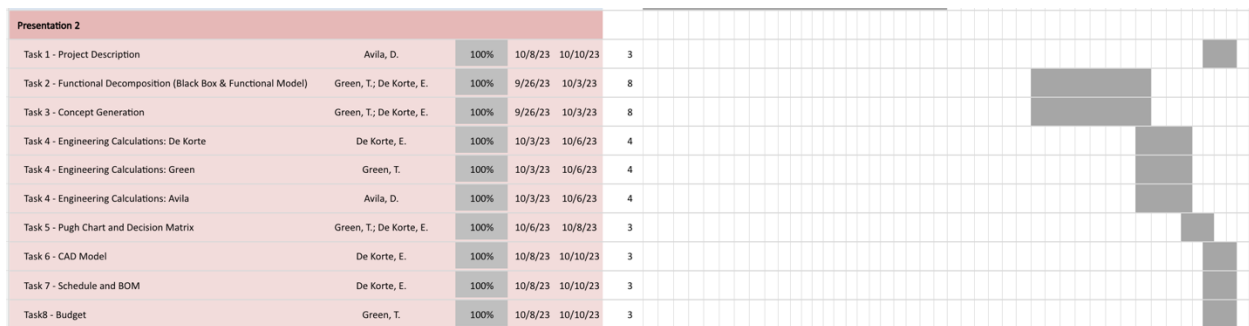

Figure 23: Portion of the Gantt chart focusing on Presentation 2

The work-breakdown-schedule can be seen in Figure 24. The team utilized this breakdown for each specific portion of the project. First would be determining what assignment is getting worked on, then the different tasks and components of the assignment were determined and assigned. Lastly, each member of the team worked on their portions of the assignment, then the team would proofread and correct any error prior to submittal.

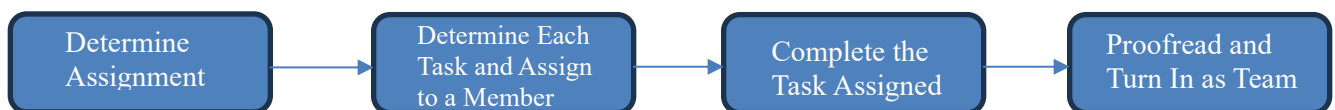

Figure 24: The work-breakdown-schedule utilized by the team

For next semester, team will be looking at ordering the final pieces needed for the final design before the end of this semester. The team plans to have a complete model constructed by mid-March, then begin testing the model after full build, with the goal of having a complete functional model by mid-April. The remainder of the semester will be focusing on finalizing any portions of the project for the final presentation.

5.2 Budget

Our team's total budget is currently \$4000, which can be split to \$2000 dollars per exoskeleton for each leg. Currently our team has spent \$93.35 on a variety of parts for our prototypes. Each of these parts that were purchased is listed in the BOM Table 2 listed below. Below in figure () shows a condensed table of our total budget, current expenses, and our future expenses. These future expenses are mainly the motor and gearbox, which will be the largest expenses of our project. During this project our team also needs to fundraise 10% of our total budget, which will total \$400. From this \$400 our team has fundraised \$93.35, which came from our team self-funding the first two prototypes. But in the future our team plans on completing this fundraising by self-funding certain purchases or by getting donations

Table 2: Expenses

Total Budget	Budget/Leg	Current Expenses	Future Expenses
\$4,000	\$2,000	\$93.35	\$1,006.80

5.3 Bill of Materials (BoM)

The Bill of Materials (Table 3) is a completed list of every part that will need to be purchased and manufactured in order for the final item to be constructed. This also helps the team determine how much one-unit costs to manufacture. In the Bill of Materials, the part, manufacturer/source, quantity per unit, cost per unit, and item number (if the part has one) can be seen. This will also help assist anyone who might want to recreate the unit, as they would know what and where each item was purchased.

Table 3: Current Bill of Materials

Current Bill of Materials					
Part	Manufacturer/Source	Quantity Per Unit	Cost Per Unit	Item Number	
Bracket (Aluminum 6061-T6, 12"x12"x0.09")	OnlineMetals.com	1	\$15.62		Manufactured
3" Pulley (Moslikely 3D printed)	E-Rigging.com	1	\$13.49		
Chain (1ft, 05B, 8mm Pitch)	McMaster-Carr	1	\$9.00	6027k91	
Sprocket (05B, 8 Teeth)	McMaster-Carr	1	\$13.05	2302K79	
Motor	Maxon	1	\$715.13	323218	
Gearbox	Maxon	1	\$294.65	370782	
Calf Cuff	Provided by Lerner	1	-		
Carbon Fiber Tubing	Rockwestscomposites	1	\$55.30	25483-L12	Manufactured
Footplate	Provided by Lerner	1	-		
Torque Sensors	Provided by Lerner	1	-		
Computer Chip and Electronic Components	Provided by Lerner	1	-		
M4-.7 30mm Bolt	Home Depot	2	\$1.25		

M4-.7 Hex Nut	Home Depot	4	\$1.25		
M4.7 Washer	Home Depot	4	\$1.25		
Stainless Steel Ball bearing	Mcmaster-Carr	1(2 needed)	\$13.17	57155k585	
Stainless Steel Ball bearing 5mm	Mcmaster-Carr	1	\$9.20	7804k138	
Stainless Steel Shoulder Screw	Mcmaster-Carr	1	\$6.31	91273A392	
Steel Hex Nuts	Mcmaster-Carr	100	\$0.05	90592A095	
M2 x .04mm Phillip Screws	Mcmaster-Carr	100	\$0.08	92000A015	
Steel Cable 2mm diameter + Clamps	Amazon	1	\$12		
PLA Material	Amazon	1	\$18		

6 Design Validation and Initial Prototyping

6.1 Failure Modes and Effects Analysis (FMEA)

To assist in the evaluation of our current design, our team decided to create an FMEA chart. This FMEA chart, which can be seen in the table below, allows our team to identify potential failures and the effects that a failure will have on the overall system. Creating this chart also allows us to better design our product with these potential modes of failure in mind. This chart allows our team to better narrow down our main parts which should be focused on during our designing and testing.

Table 4: FMEA table

Part # and Functions	Potential Failure Mode	Potential Effect(s) of Failure	Severity (S)	Potential Causes and Mechanisms of Failure	Occurrence (O)	Current Design Controls Test	Detection (D)	RPN	Recommended Action
1 Bracket to hold Motor	Stress Rupture & low Cycle Fatigue	Total loss of function ability	9	Incorrect bolt tolerances, incorrect design, and material selection	4	Applying various forces to the bracket and seeing if the bracket moves	5	180	Make sure Bracket design can withstand the forces applied
2 Bolts & Screws	Impact Fatigue	Damage to the Rod and total loss of function ability	7	Loose tolerances and wrong size selection	4	Applying various forces to the bracket and seeing if the tolerances are correct	5	140	Design Bracket and rod for tight tolerances
3 Rod	Surface Fatigue & Stress Rupture	Shearing of the rod and deformation of the Rod	8	Have a sustained load at 1 point of the bracket and bracket not being fully tighten to the rod	6	Applying various forces to the bracket and seeing if the tolerances are correct	6	288	Make sure Bracket Design and tolerances are Correct
4 Sprocket	Cycle Fatigue	Deformation or shearing of Sprocket teeth	7	Stress on sprocket may cause deformation overtime	3	Have a durability test to see how many cycles the sprocket can handle	4	84	Make sure sprocket material Selection is correct
5 Chain	Impact Deformation	chain having deformation in the links or pins causing it to break	7	The tension force acting on the the chain	3	Durability test to see if the chain deforms over a certain amount of cycles	4	84	Make sure the correct chain material is selected
6 Pulley	Surface Fatigue Wear	Surface damage of pulley and a decrease of effectiveness	2	Friction of the wire rubbing on the pulley	2	Cycle test to see if there is any material erosion occurring on the pulley	8	32	Make sure that the material selected wont erode
7 Pulley Wire	Deformation Wear	Wire deforming over time	4	Tension Stress on wire causing the wire to deform overtime	2	Durability test to see if the wire deforms overtime	2	16	Make sure the material selected can withstand the force
8 Foot Plate	Impact Fracture	Fracturing of footplate at attachment point to the pulley	8	Force acting on footplate are greater than what it can handle	2	Durability test to see if the footplate will break will in use	5	80	Do force analysis on footplate
9 Bearing	Cycle Fatigue	Increase in friction in the bearings and a loss of power	3	Deterioration of bearings and lubrication in the bearing getting dirty	6	Cycle Test to see how the model will work overtime	3	54	Make sure to keep the bearing as clean as possible
10 Motor	Cycle Fatigue	Loss of torque or the motor becoming nonfunctional	7	Deterioration of motor part over multiple cycles	2	Cycle test to see if there is a loss of power overtime	3	42	Make sure the motor selected can handle the number of cycles required
11 Calf Cuff	Impact Fracture	Calf cuff breaking	2	Impact force of the user breaking the calf cuff	1	Durability Tests to see if the calf cuff can	4	8	Make sure the calf cuff is accessible for

					<i>withstand the forces</i>		<i>all users</i>
<i>12 Wire Clamps</i>	<i>Cycle Fatigue</i>	<i>Pulley cable disconnecting</i>	<i>7</i>	<i>Pulling forces cause the clamps to loosen and fail.</i>	<i>2</i>	<i>Cycle tests to see if the clamps will loosen overtime</i>	<i>5 70</i>
							<i>Make sure that clamps are installed correctly before running tests.</i>

Using this FMEA table we were able to determine the risk tradeoff with each of the potential failures. So, using risk priority numbers calculated in the table above we were able to assess that the parts with the largest risk are the bracket, rod, bracket screws, and the wire clamps. So, our team is going to focus our attention on these areas during our design and testing. Which is because these parts have the most risk involved if they fail.

6.1.1 Potential Critical Failure 1: Motor mount Bracket Failure

The failure of the motor mount bracket will most likely come from the stress acting on the holes that will attach the sprocket to the bracket and the hole which will attach the bracket to the rod. Shearing may occur at these points, which would compromise the entire gear and pulley system and will cause our product to fail. To help mitigate these issues we will make sure that the material selected will be able to withstand the forces which will be applied.

6.1.2 Potential Critical Failure 2: Screw Shearing

A failure of any of the motor mounting screws the motor to loosen and will cause more force to act on the remaining screws. Which may cause a chain effect to cause the rest of the screws to fail, causing the motor to detach from the bracket. To make sure that this doesn't occur, our team is making sure that the diameter of the screws and material chosen will be able to withstand the forces acting upon them.

6.1.3 Potential Critical Failure 3: Rod Failure

A failure of our rod would cause the entire assembly to fail, since the rod supports all mechanisms involved with the assembly. Which is why it is important that during our designing stage the forces acting a distributed across the entire rod and not at a single point. We also need to make sure that our screw holes have tight tolerances, since an unsecure bolt could cause damage to the rod and overtime cause the rod to fail.

6.1.4 Potential Critical Failure 4: Sprocket Failure

A sprocket failure can occur from a variety of things, such as bending or cracking of the sprocket teeth. Which can be caused by the cycle loading while in use. If this part were to fail it would cause the entire assembly to stop functioning. Which is why it is important that the selected sprocket material will be able to withstand the forces applied and not yield.

6.1.5 Potential Critical Failure 5: Chain Failure

A potential failure of the chain may occur from the chain links breaking under the load which would be applied to it. A break in any of the chain links would cause the pulley system to fail and would cause the exoskeleton to lose power. This is why selecting the correct chain size and material is crucial since a lot of force will be acting on the chain.

6.1.6 Potential Critical Failure 6: Pulley Gear Failure

A failure of the pulley gear will most likely occur from the pulley clamp breaking the pulley gear's stopper. If this occurred, it would cause the pulley to be unable to rotate in the direction of the side

which the stopper was broken. If this were to occur, we would need to replace the entire pulley and pulley wire before the exoskeleton would be able to function again.

6.1.7 Potential Critical Failure 7: Pulley Wire Failure

A pulley wire could end up breaking from the strain of the forces acting on it from the motor. This wire could also tear because of the pulley clamp being improperly installed. But since this part is easily replaced and would cause the exoskeleton to be nonoperational for a short period of time. Our team believes that the pulley wire is a problem that we don't need to focus to much attention on.

6.1.8 Potential Critical Failure 8: Foot Plate Failure

The footplate has a variety of ways in which it could fail. The footplate could develop stress fractures from the forces acting on it and eventually completely break. Making sure the footplate doesn't break is important since this is going to be something that our client will provide for us. So, making sure that the client won't have to provide two footplates is important.

6.1.9 Potential Critical Failure 9: Bearing Failure

A bearing failure can occur from an accumulation of dirt and other debris causing the bearing to lose its rotational ability. This loss in bearing rotational speed would cause the motor to work harder, which could cause the motor to stall or be overworked. This is an issue that will occur overtime and will be hard to notice, so our team is planning on conducting periodic checks on the bearings to make sure they are functioning correctly.

6.1.10 Potential Critical Failure 10: Motor failure

The motor could fail because of a variety of things from the motor stalling out because of excessive loads or the motor not receiving the correct power source to function properly. To ensure that this doesn't happen our team is going to design our system to make sure that our loads will not exceed the capabilities of our selected motor. We will also make sure that the battery selected will meet the specifications of our motor which are given online.

6.1.11 Potential Critical Failure 11: Calf Cuff Failure

The calf cuff has a very small chance of ever failing since there will only be a very small amount of force acting on it. But if the user were to pull too hard to tight the calf cuff it could end up breaking. But since this is more of a human error rather than a design error our team believes that this isn't an issue we should focus on.

6.1.12 Potential Critical Failure 12: Pulley Wire Clamps Failure

The pulley clamps are used to both connect the steel wire and create the rotational movement of the pulley. So, the major failure that can occur with the pulley clamp is that it may loosen over time and fail to keep the steel wires connected or may cause the pulley system to lose tension. But since this is a cheap and easily replaceable part, our team decided to not focus to much of our attention on this part.

6.2 Initial Prototyping

Each prototype attempts to answer the question of ‘how does the bracket integrate with the carbon fiber rod?’ By changing the design of the bracket, we had to determine if the pulley cables would be able to pass from the cable sprocket through the existing cuts in the rod to the motor, or if we would have to adjust the position of the extruded cuts.

After communicating with Dr. Lerner and deciding which bracket design was best, it was revealed that the pulley cables could not pass from the cable sprocket to the motor without interfering with the carbon fiber rod. If the cables were passed through the rod from the ankle mount, it would cause interference and the pulley system would not work without grinding away pieces of the rod.

Based on this information, it was necessary to reposition the extruded cuts on the carbon fiber rod in order for the pulley cable to pass from the ankle mount to the motor without interfering with the rod. The ideal location for the new cuts was 20 mm below the lower bolt bore. Reusing the dimensions of an 11x30mm cut would effectively allow the cable to pass through the center of the carbon fiber rod without interference and transmit the calculated torque.

6.3 Other Engineering Calculations

6.3.1 Variable Analysis of Support Reactions – Diego Avila

In order to find the reactions of the supports, it was necessary to identify the angle at which the applied force would be acting upon the supports. After finding the angle, trigonometry ratios can be used to find the force in axial and radial directions. The forces are solved algebraically because the team is consistently changing relations for each bracket design and it is more practical to identify new quantities (length between supports and the ankle, angle measurements), and then input them into a pre-solved equation.

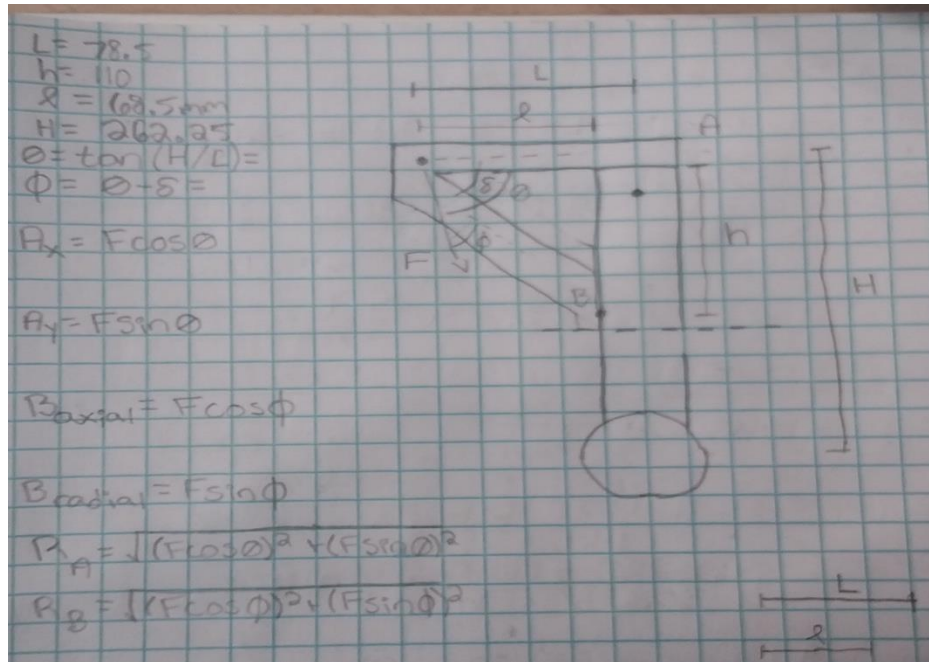

Figure 25: Calculations for the variable analysis of support reactions

$$A_x = F * \cos (\theta) \quad (14)$$

$$A_y = F * \sin (\theta) \quad (15)$$

6.3.2 Calculating the cost for the bracket to be CNCed – Emma De Korte

During a meeting with the team’s client, it was mentioned that machining the bracket could be very costly and other modes of manufacturing might need to be looked at. In order to get a general idea of the cost of getting the final bracket design machined, the team looked at determining the cost of utilizing a CNC machine.

The average cost of getting an item CNCed, is \$80 an hour for a basic common CNC machine, where is a higher quality, 5-axis CNC machine is used, it may cost up to \$200 an hour. Therefore, calculations were made for \$80 an hour and \$200 an hour.

To determine the cost, the machining time needs to be calculated using Equation 16. The feed rate within this equation is calculated by using Equation 17.

$$\text{Machining Time} = \frac{\text{length of cut (mm)}}{\text{feed (mm per revolution)}} * \text{revolutions per min} \quad (16)$$

$$\text{Feed Rate} = \text{speed} * \# \text{ of Flutes} * \text{Chip load} \quad (17)$$

For feed rate, the speed of the machine ranges from 12000 to 24000, therefore the average is 18000. There are two flutes used if aluminum is being machined and four flutes if steel is being machined.

The team plans to use aluminum, meaning two flutes will be used and 0.4 is the chip load used. For the length of each bracket, Bracket 3 was 135 mm and Bracket 4 was 100 mm.

In the end. Bracket 3 would cost \$73.92-\$185.15 and Bracket 4 would cost \$24.00-\$60.00.

6.3.3 Calculating Force acting on the teeth of the sprocket - Joscelyn Green

To help us in selecting the material which our sprocket should be made out from, I calculated the forces acting on the sprocket teeth. To calculate the forces acting on the teeth I used the Lewis equation, which calculates the bending stress acting on the teeth. Then using Equation 18 from previous calculation for the shear on the bolts to calculate the load acting on the teeth from the torque. Using this calculated load and the specifications of the sprocket from the supplier's website, I was able to calculate the bending stress acting on the sprocket teeth using Equation 19. The transmitted load acting on the teeth is 388 N. Then the diametral pitch calculated using 8 mm pitch diameter and 8 teeth is 1 teeth/mm. Then the face width of our sprocket is 2.8 mm. Then using the chart given in reference [42] we get a Lewis form factor of .245. Using these values, we get a bending stress of 565 N/mm² which is equal to 565 Mpa. Then using this value and looking at various material properties we determined that a high strength steel would be able to withstand the force acting on the sprocket.

$$\sigma = \frac{W^t P}{F Y} \quad (18)$$

$$P = \frac{\text{Number of Teeth}}{\text{Pitch Diameter}} \quad (19)$$

6.4 Future Testing Potential

In the future, different items are wished to be tested by the client or the team. These were determined by the given customer requirements and engineering requirements. A weight test will be completed to ensure the item is under 1 kg, and that will be carried out by a scale. FEA testing will be completed. A timed test utilizing a stopwatch to determine if the unit can be removed in a timely manner. A durability test utilizing the Biomechatronic Lab, this will be testing the amount of cycle the device can withstand, wanting it to last >100,000 steps. Lastly, a cost evaluation utilizing the Bill of Materials and a device protrusion test to make sure all items are less than 10 cm from the body using a measuring device. All testing procedures will be carried out within the second semester of this project.

7 CONCLUSIONS

The team is reiterating a robotic ankle exoskeleton that was created during the 2021-2022 academic year, alongside the NAU Biomechatronics Lab. The team has gone through a literature review to help determine what areas of the design need to be focused and the beginning stages of mathematical modeling for specific areas of the design, as well as benchmarking to determine where our design can be improved against existing designs. A black box and functional model were created to understand the functionality of the exoskeleton. The team then went through a concept generation phase where there were multiple designs created based on three different sub sections. Then a Pugh chart and decision matrix were made in order to determine the best design to move forward with. More calculations were carried out to determine if the design the team is going with is still good to be used. An initial prototype of the bracket was made to see how bracket designs mated with the tubing design. Overall, currently the team will move forward with prototyping a completed exoskeleton design to see if all parts matches were needed and if any adjustments need to be made prior to constructing the final device for testing. After creation of the full design, the entire prototype will be tested prior to creating the final design.

8 REFERENCES

- [1] DOI 10.1109/TBME.2021.3137447, IEEE Transactions on Biomedical Engineering
- [2] “Fully active chain and sprocket ankle exoskeleton for Rehabilitation Assistance,” BIOMECHATRONICS LAB, https://www.ceias.nau.edu/capstone/projects/ME/2022/22F_P12BiomechLab/Documents.html (accessed Oct. 27, 2023).
- [3] “Robotic ankle H3: Technaid - leading motion,” Technaid, <https://www.technaid.com/products/robotic-ankle-technaid/> (accessed Oct. 27, 2023).
- [4] “ReStore™ soft exo-suit for stroke rehabilitation - REWALK robotics,” ReWalk Robotics, Inc., <https://rewalk.com/restore-exo-suit/> (accessed Oct. 27, 2023).
- [5] G. Orekhov, Y. Fang, C. F. Cuddeback, and Z. F. Lerner, “Usability and performance validation of an ultra-lightweight and versatile untethered robotic ankle exoskeleton,” *Journal of NeuroEngineering and Rehabilitation*, vol. 18, no. 1, 2021. doi:10.1186/s12984-021-00954-9
- [6] BDYNAS. (2020). SHIGLEY’S MECHANICAL ENGINEERING DESIGN, 11TH EDITION, SI UNITS (11th ed.). MCGRAW-HILL EDUCATION (AS).
- [7] Cammit, Joel (2013). Exploring Robotics, <https://www.google.com/url?sa=t&source=web&rct=j&opi=89978449&url=http://www.sci.brooklyn.cuny.edu/~kammet/syllabus-spr13.pdf&ved=2ahUKEwj3pe3x7WBAX>
- [8] “Gear Train: Gear Ratios, Torque, and Speed Calculations”. <https://www.smlase.com/entries/mechanism/gear-train-gear-ratio-torque-and-speed-calculation/>
- [9] Groover, M. P. (2021). Fundamentals of modern manufacturing: materials, processes, and systems. Wiley.
- [10] Lerner, Zachary (2022). Usability and performance validation of an ultra-lightweight and versatile untethered robotic ankle exoskeleton. Northern Arizona University. <https://doi.org/10.1186/s12984-021-00954-9>.
- [11] Lewsley, Fred (2013). Functioning 'mechanical gears' seen in nature for the first time. University of Cambridge. <https://www.cam.ac.uk/research/news/functioning-mechanical-gears-seen-in-nature-for-the-first-time>
- [12] G. S. Sawicki, O. N. Beck, I. Kang, and A. J. Young, “The exoskeleton expansion: Improving walking and running economy - journal of Neuroengineering and Rehabilitation,” BioMed Central, <https://jneuroengrehab.biomedcentral.com/articles/10.1186/s12984-020-00663-9> (accessed Nov. 28, 2023).

- [13] C. Siviya et al., “Opportunities and challenges in the development of exoskeletons for locomotor assistance,” *Nature News*, <https://www.nature.com/articles/s41551-022-00984-1> (accessed Nov. 28, 2023).
- [14] S. University, “Exoskeleton makes walking faster, less tiring,” *Stanford News*, <https://news.stanford.edu/2022/10/12/exoskeleton-makes-walking-faster-less-tiring/> (accessed Nov. 28, 2023).
- [15] S. Massardi et al., “Characterization and evaluation of human-exoskeleton interaction dynamics: A Review,” *Sensors (Basel, Switzerland)*, <https://www.ncbi.nlm.nih.gov/pmc/articles/PMC9183080/> (accessed Nov. 28, 2023).
- [16] R. C. Hibbeler, *Engineering Mechanics*. Boston: Prentice Hall, 2015.
- [17] T. K. Uchida, *Biomechanics of Movement: The Science of Sports, Robotics, and Rehabilitation*. MIT Press, 2021.
- [18] C. L. Brockett and G. J. Chapman, “Biomechanics of the ankle,” *Orthopaedics and Trauma*, vol. 30, no. 3, pp. 232–238, 2016. doi:10.1016/j.mporth.2016.04.015
- [19] C. W. CHAN and A. RUDINS, “Foot biomechanics during walking and running,” *Mayo Clinic Proceedings*, vol. 69, no. 5, pp. 448–461, 1994. doi:10.1016/s0025-6196(12)61642-5
- [20] A. Kharb, V. Saini, Y. K. Jain, and S. Dhiman, “A REVIEW OF GAIT CYCLE AND ITS PARAMETERS,” *Journal of Computational Engineering & Management*, vol. 13, pp. 78–83, Jul. 2011. [Online]. Available: https://www.researchgate.net/profile/Surender-Dhiman/publication/268423123_A_review_of_gait_cycle_and_its_parameters/links/582f259108ae138f1c035005/A-review-of-gait-cycle-and-its-parameters.pdf
- [21] “What is cerebral palsy?,” Centers for Disease Control and Prevention, <https://www.cdc.gov/ncbddd/cp/facts.html> (accessed Oct. 27, 2023).
- [22] T. Jung, Y. Kim, L. E. Kelly, and M. F. Abel, “Biomechanical and perceived differences between Overground and treadmill walking in children with cerebral palsy,” *Gait & Posture*, vol. 45, pp. 1–6, 2016. doi:10.1016/j.gaitpost.2015.12.004
- [23] A. I. Alateyah et al., “Design optimization of a 4-bar exoskeleton with natural trajectories using unique gait-based synthesis approach,” *De Gruyter*, <https://www.degruyter.com/document/doi/10.1515/eng-2022-0405/html?lang=en> (accessed Sep. 19, 2023).
- [24] X. Wang, S. Guo, B. Qu, M. Song, and H. Qu, “Design of a Passive Gait-based Ankle-foot Exoskeleton with Self-adaptive Capability - Chinese Journal of Mechanical Engineering,” *SpringerOpen*, <https://cjme.springeropen.com/articles/10.1186/s10033-020-00465-z> (accessed Sep. 19, 2023).
- [25] Orekhov, Greg & Fang, Ying & Cuddeback, Chance & Lerner, Zachary. (2021). Usability and performance validation of an ultra-lightweight and versatile untethered robotic ankle exoskeleton. *Journal of NeuroEngineering and Rehabilitation*. 18. 10.1186/s12984-021-00954-9.

- [26] T. Philpot and J. S. Thomas, Mechanics of Materials: An Integrated Learning System. Estats Units d'Àmerica: Wiley, 2020
- [27] W. D. Callister and D. G. Rethwisch, Materials Science and Engineering: An Introduction. Milton, QLD: John Wiley and Sons Australia, Ltd, 2021.
- [28] ASM Material Data Sheet, <https://asm.matweb.com/search/SpecificMaterial.asp?bassnum=ma6061t6> (accessed Sep. 19, 2023).
- [29] F. S. S. Instruments et al., "AISI 1018 Mild/Low Carbon Steel," AZoM.com, <https://www.azom.com/article.aspx?ArticleID=6115> (accessed Sep. 19, 2023).
- [30] F. S. S. Instruments et al., "AISI 4140 Alloy Steel (UNS G41400)," AZoM.com, <https://www.azom.com/article.aspx?ArticleID=6769> (accessed Sep. 19, 2023).
- [31] ASM Material Data Sheet, <https://asm.matweb.com/search/SpecificMaterial.asp?bassnum=mtp641> (accessed Sep. 19, 2023).
- [32] "Aluminum Sheet/Plate 6061 T6/T651," Aluminum Sheet 6061 T6/T651 | Online Metals, <https://www.onlinemetals.com/en/buy/aluminum-sheet-plate-6061-t6-t651> (accessed Sep. 19, 2023).
- [33] "What is Price of Low-carbon Steel - Definition," Material Properties, <https://material-properties.org/what-is-price-of-low-carbon-steel-definition/> (accessed Sep. 19, 2023).
- [34] "ASTM Steel A36 Steel Plate 50mm Thick A36 S235 S355 Steel Plate Price Per Kg," Astm Steel A36 Steel Plate 50mm Thick A36 S235 S355 Steel Plate Price Per Kg - Buy Astm Steel, Hot Rolled Carbon Steel Plate, Astm A36 Steel Plate Product on Alibaba.com, https://www.alibaba.com/product-detail/ASTM-Steel-A36-Steel-Plate-50mm_1600329933029.html?spm=a2700.7724857.0.0.2edb28558RMN1z (accessed Sep. 19, 2023).
- [35] "Titanium 6Al-4V Grade 5, UNS R56400 Titanium Grade 5 Product Supplier," Titanium Grade 5 Ti-6Al-4V Supplier, Titanium Gr.5 Price Per Kg in India, <https://www.fastwell.in/titanium-grade-5.html> (accessed Sep. 19, 2023).
- [36] World Material, "Weight & Density of Aluminum 6061 g/cm³, lbs/in³, kg/m³, g/ml, lb/ft³, g/mm³, Cubic Inch," World Material, <https://www.theworldmaterial.com/weight-density-of-aluminum/> (accessed Sep. 19, 2023).
- [37] "Density of steel," Home, <https://www.pipingmaterial.ae/blog/density-of-steel/#:~:text=Density%20of%20carbon%20steel%20and,%2C%20at%207%2C860%20kg%2Fm3.> (accessed Sep. 19, 2023).
- [38] "4140 Product Guide," alloy-steel 4140 Product Guide from Online Metals, <https://www.onlinemetals.com/en/product-guide/alloy/4140> (accessed Sep. 19, 2023).
- [39] Properties of Titanium - Roy Mech, https://roytech.org/Useful_Tables/Matter/Titanium.html#:~:text=Titanium%20is%20a%20light%20metal,than%20iron%20at%201560oC. (accessed Sep. 19, 2023).

- [40] “Fully active chain and sprocket ankle exoskeleton for Rehabilitation Assistance,” BIOMECHATRONICS LAB, https://www.ceias.nau.edu/capstone/projects/ME/2022/22F_P12BiomechLab/Documents.html (accessed Nov. 26, 2023).
- [41] “The laboratory of Zach F. Lerner, ph.D.,” Biomechatronics Lab, <https://biomech.nau.edu/> (accessed Nov. 26, 2023).
- [42] Mercer University, http://faculty.mercer.edu/jenkins_he/documents/Gears4StressandSelection.pdf (accessed Nov. 27, 2023).
- [43] BDYNAS. (2020). SHIGLEY’S MECHANICAL ENGINEERING DESIGN, 11TH EDITION, SI UNITS (11th ed.). MCGRAW-HILL EDUCATION (AS).
- [44] Cammit, Joel (2013). Exploring Robotics, <https://www.google.com/url?sa=t&source=web&rct=j&opi=89978449&url=http://www.sci.brooklyn.cuny.edu/~kammet/syllabus-spr13.pdf&ved=2ahUKewjb3pe3x7WBAX>
- [45] “Gear Train: Gear Ratios, Torque, and Speed Calculations”. <https://www.smlease.com/entries/mechanism/gear-train-gear-ratio-torque-and-speed-calculation/>
- [46] Groover, M. P. (2021). Fundamentals of modern manufacturing: materials, processes, and systems. Wiley.
- [47] Lerner, Zachary (2022). Usability and performance validation of an ultra-lightweight and versatile untethered robotic ankle exoskeleton. Northern Arizona University. <https://doi.org/10.1186/s12984-021-00954-9>.
- [48] Lewsley, Fred (2013). Functioning 'mechanical gears' seen in nature for the first time. University of Cambridge. <https://www.cam.ac.uk/research/news/functioning-mechanical-gears-seen-in-nature-for-the-first-time>
- [49] “Guide to calculating speeds and feeds,” CNC Router Bits, https://cncrouterbits.com.au/technical_speeds_feeds#:~:text=For%20most%20material%20that%20you,of%20the%20spindle%20being%20used. (accessed Nov. 7, 2023).
- [50] “CNCShop: CNC router machine - calculating feeds and speeds,” CNCShop US, <https://cncshop.com/pages/calculating-feeds-and-speeds#:~:text=Your%20CNC%20spins%20the%20bit,be%2014%20C400%20mm%20per%20minute.> (accessed Nov. 7, 2023).
- [51] Harvey Performance Company and Harvey Performance Company Harvey Performance Company’s team of engineers works together to ensure that your every machining challenge – from tool selection and application support to designing the perfect custom tool for your next job – is rectified with , “Why flute count matters - in the loupe - machinist blog,” Harvey Performance Company, <https://www.harveyperformance.com/in-the-loupe/flute-count-matters/#:~:text=The%20widely%20accepted%20rule%20of,machining%20steel%20and%20harder%20alloys.> (accessed Nov. 7, 2023).

[52] Ronan YeRapid Prototyping & Rapid Manufacturing ExpertSpecialize in CNC machining, “How much does CNC milling cost - tips to reduce your expenses?,” Rapid Prototyping & Low Volume Production, <https://www.3erp.com/blog/cnc-milling-cost/#:~:text=The%20operator%20salary%20of%20CNC,for%205%2Daxis%20CNC%20machining.> (accessed Nov. 7, 2023).

9 APPENDICES

9.1 Appendix A: Gantt Chart

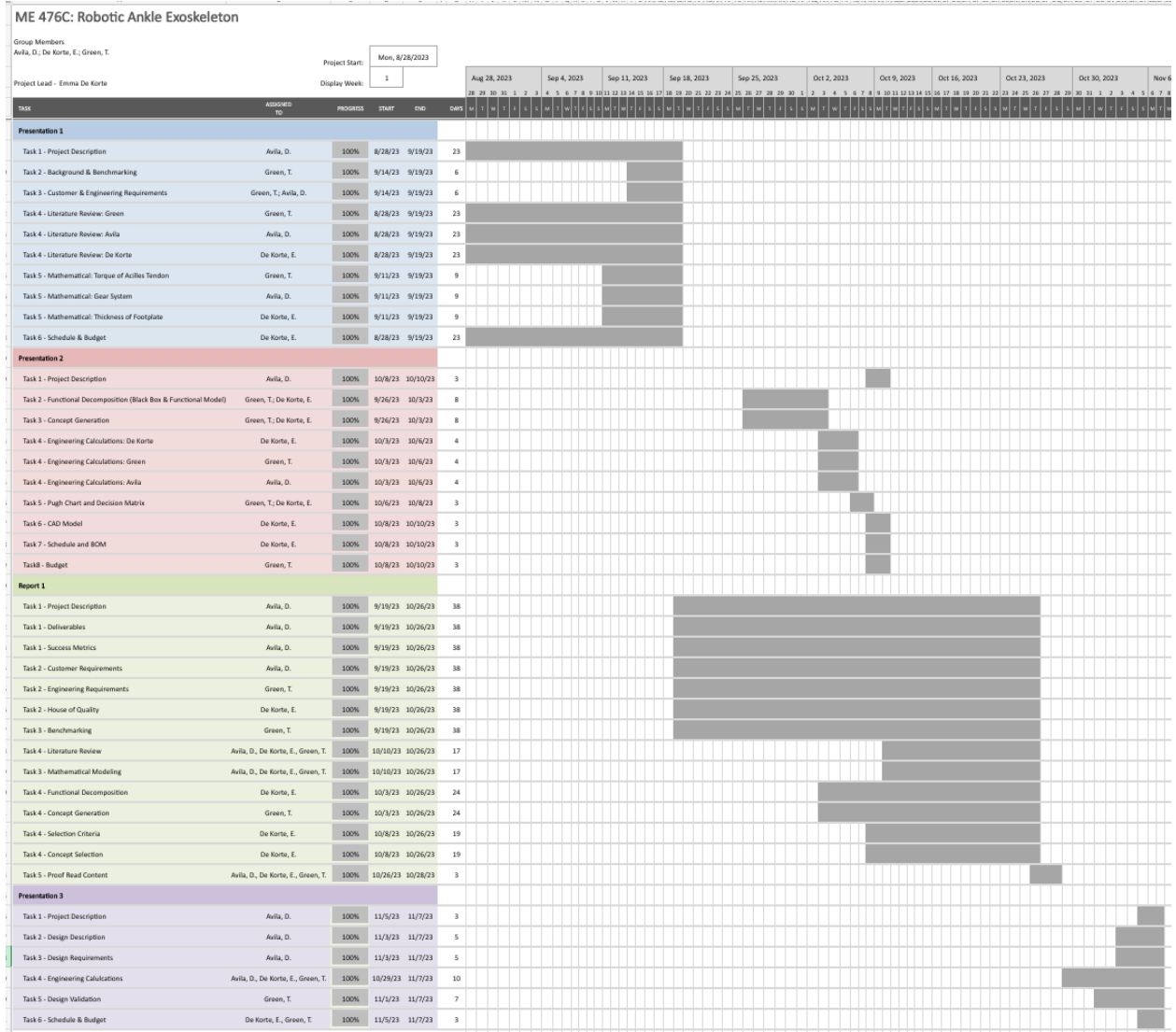

Appendix A: Full Version of Gantt Chart