

ITEM NO.	PART NUMBER	QTY.
1	SOLAVEM Shell (Final)	1
2	Alierons	2
3	Charge Contoller (Solar)	1
4	Motor	1
5	CF Shafts (Shell)	3
6	Reciever	1
7	Servos	2
8	Servo Arm	2
9	Prop	1
10	Inside Ribs (Assembly)	1
11	Solar Cell Assembly	1

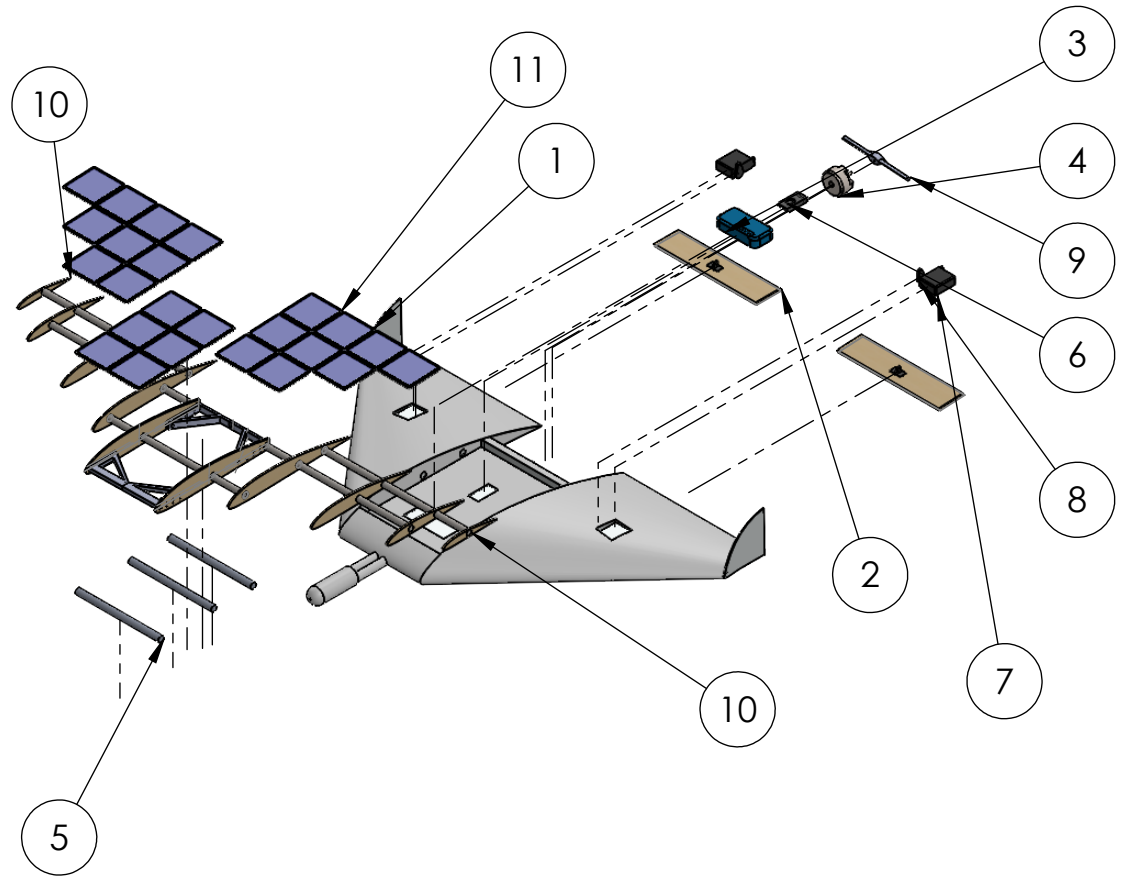

UNLESS OTHERWISE SPECIFIED: DIMENSIONS ARE IN MILLIMETERS SURFACE FINISH: TOLERANCES: LINEAR: ANGULAR:			FINISH:		DEBURR AND BREAK SHARP EDGES		DO NOT SCALE DRAWING		REVISION 1		
DRAWN Mitch Anderson						DATE 11/20/22					
CHK'D											
APPV'D											
MFG											
Q.A						MATERIAL:					
						WEIGHT:					
						TITLE: Sol Avem Exploded View					
						DWG NO. ExplodedView_Drawing					
						SCALE: 1:20					
						SHEET 1 OF 1					

6

5

4

3

2

1

D

D

C

C

B

B

A

A

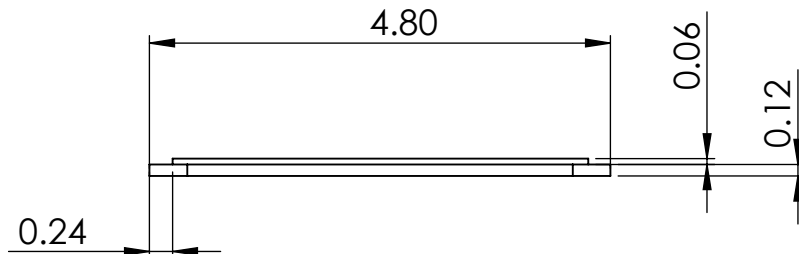
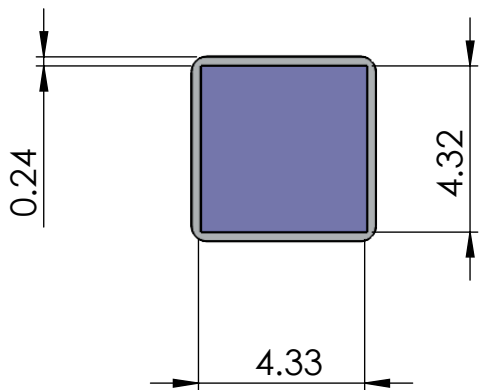
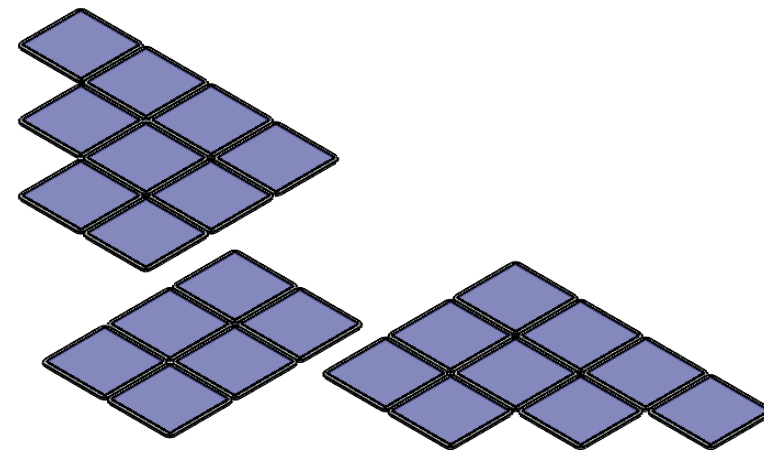
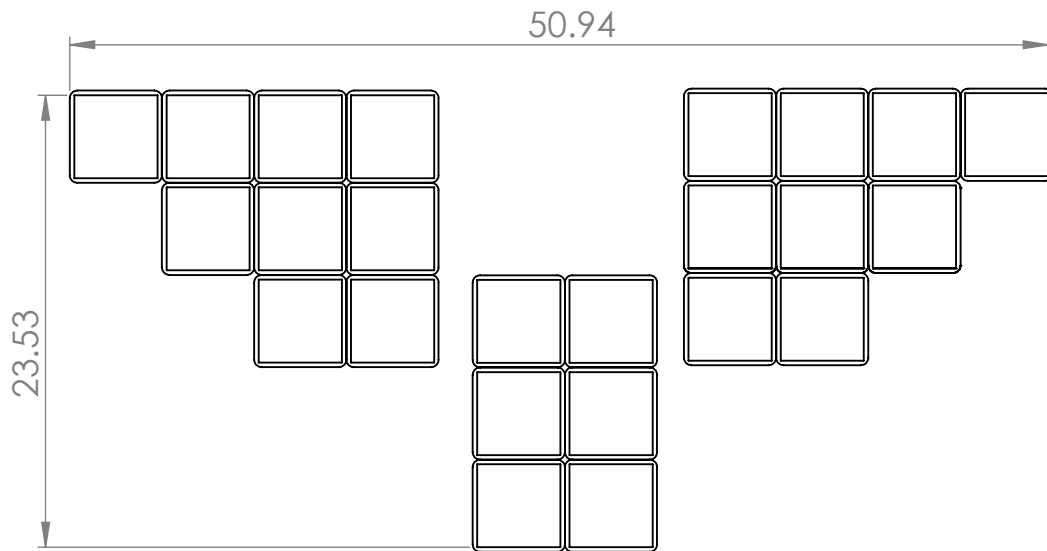

UNLESS OTHERWISE SPECIFIED: DIMENSIONS ARE IN MILLIMETERS SURFACE FINISH: TOLERANCES: LINEAR: ANGULAR:				FINISH:		DEBURR AND BREAK SHARP EDGES		DO NOT SCALE DRAWING		REVISION 1	
DRAWN Mitch				SIGNATURE MA		DATE 11/20/22		TITLE: SolarCellDrawing			
CHK'D								DWG NO. 1			
APPV'D								A4			
MFG								SCALE:1:20			
Q.A						MATERIAL:		SHEET 1 OF 1			
						WEIGHT:					

6

5

4

3

2

1

6

5

4

3

2

1

D

D

C

C

B

B

A

A

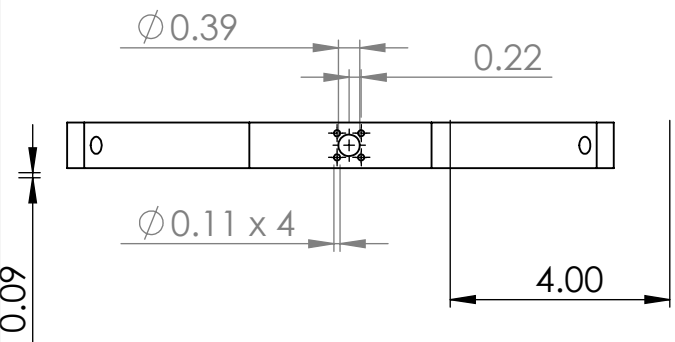
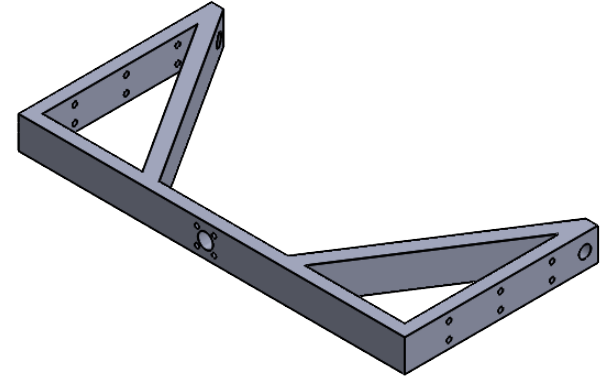
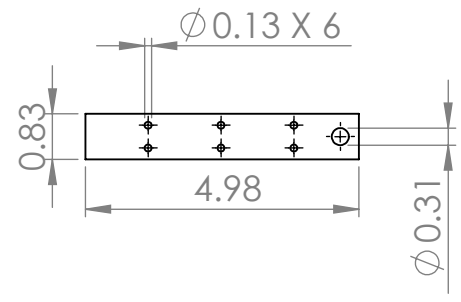
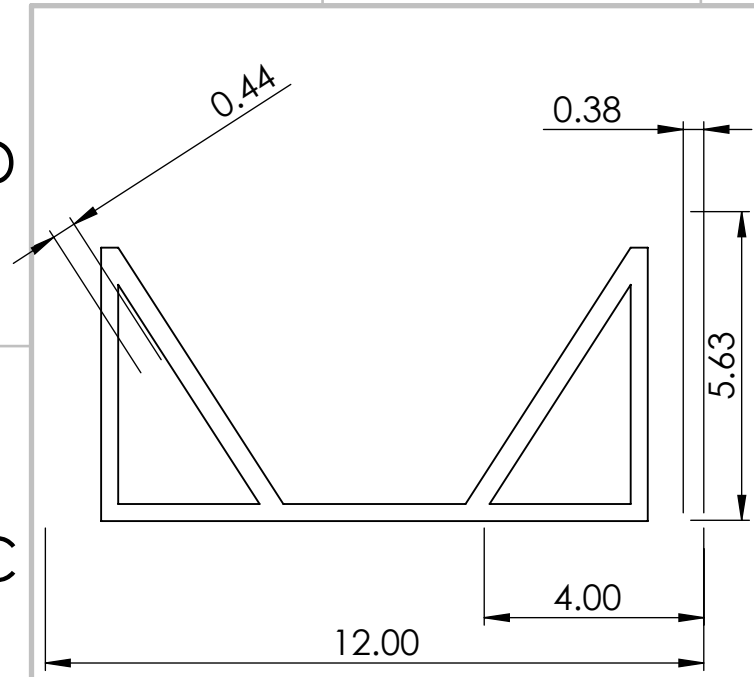

UNLESS OTHERWISE SPECIFIED: DIMENSIONS ARE IN MILLIMETERS SURFACE FINISH: TOLERANCES: LINEAR: ANGULAR:				FINISH:		DEBURR AND BREAK SHARP EDGES		DO NOT SCALE DRAWING		REVISION 1					
								TITLE: <h1>Motor Mount</h1>							
DRAWN		NAME		SIGNATURE		DATE						MATERIAL:		DWG NO.	
CHK'D						11/23/22								3	
APPV'D														A4	
MFG															
Q.A								WEIGHT:		SCALE:1:5					
										SHEET 1 OF 1					

6

5

4

3

2

1

6 5 4 3 2 1

D

D

C

C

B

B

A

A

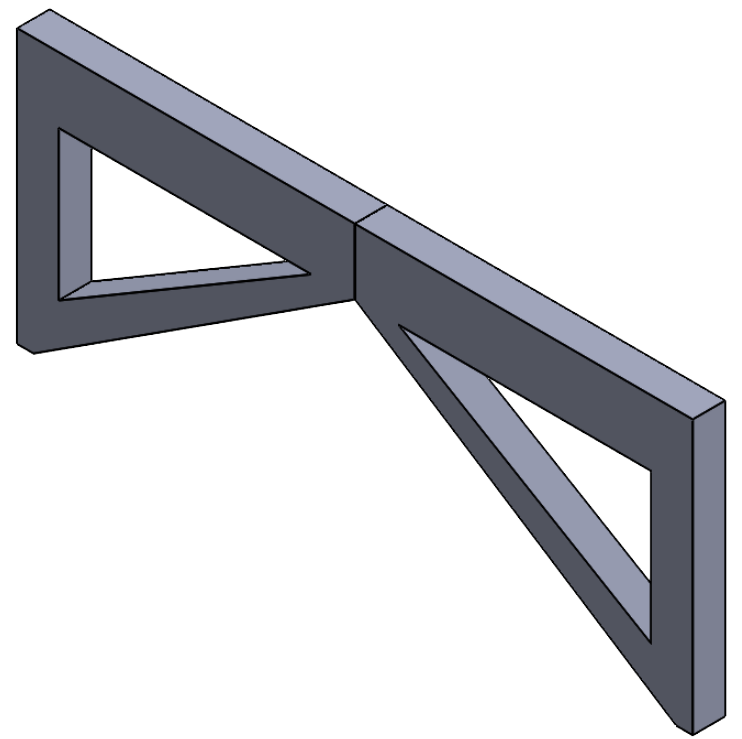
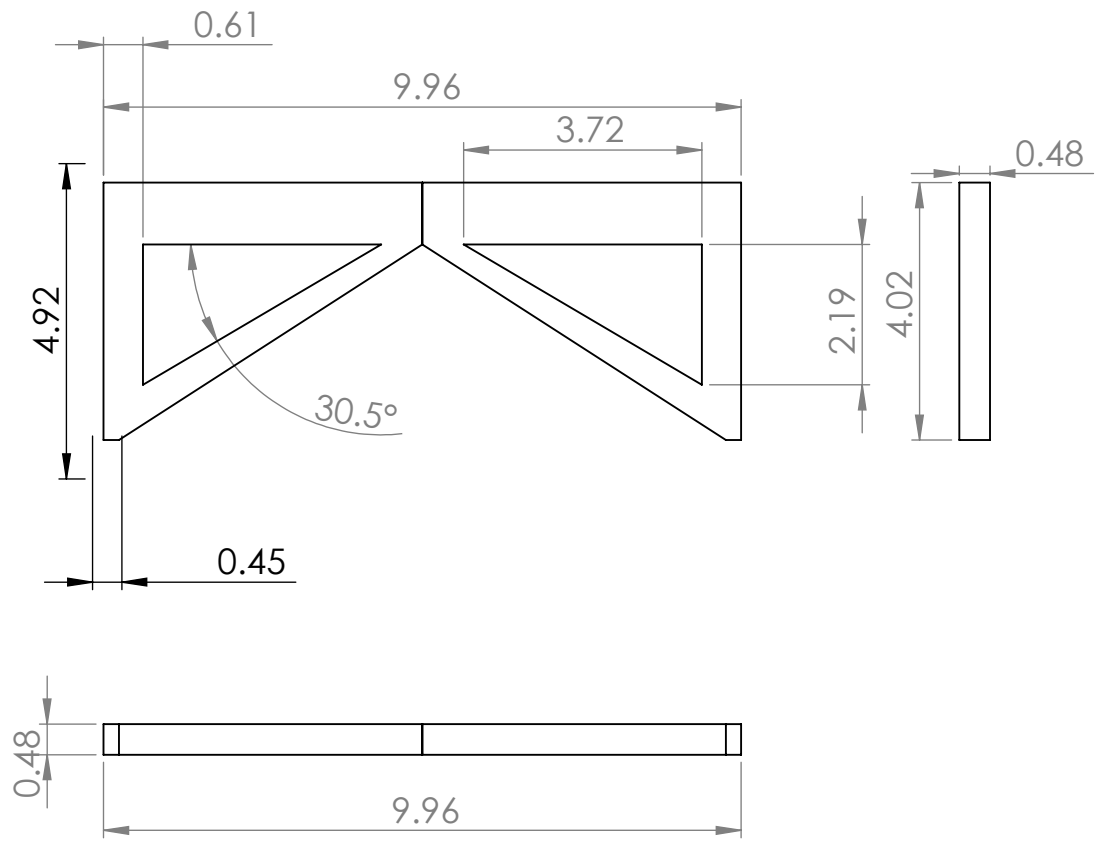

UNLESS OTHERWISE SPECIFIED: DIMENSIONS ARE IN MILLIMETERS SURFACE FINISH: TOLERANCES: LINEAR: ANGULAR:				FINISH:		DEBURR AND BREAK SHARP EDGES		DO NOT SCALE DRAWING		REVISION 1			
								TITLE: <h1>FrontFrame</h1>					
DRAWN		NAME		SIGNATURE		DATE							
CHK'D													
APPV'D													
MFG													
Q.A				MATERIAL:				DWG NO. 6					
				WEIGHT:				SCALE:1:2					
								SHEET 1 OF 1					

6 5 4 3 2 1

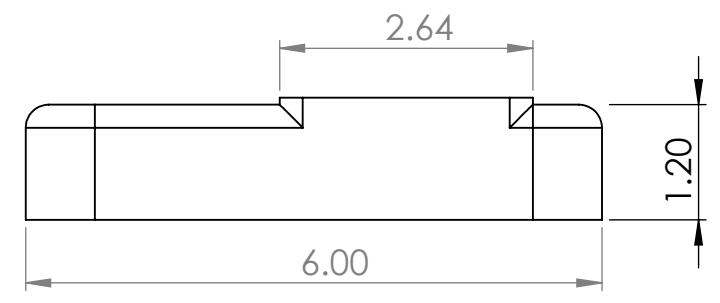
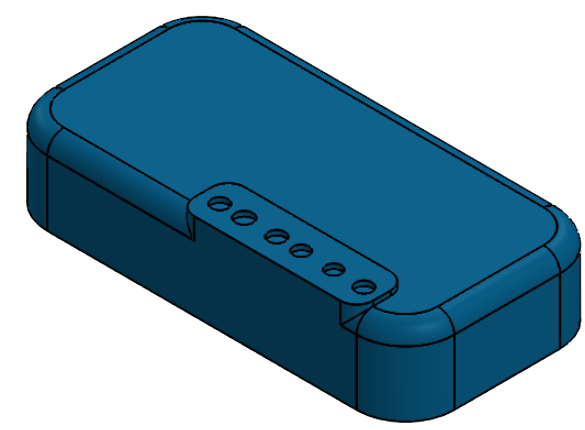
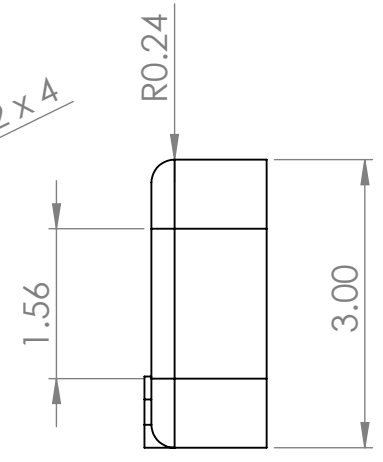
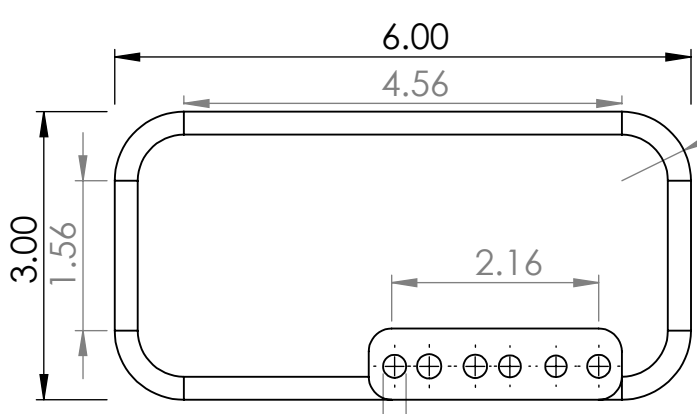

UNLESS OTHERWISE SPECIFIED: DIMENSIONS ARE IN MILLIMETERS SURFACE FINISH: TOLERANCES: LINEAR: ANGULAR:				FINISH:		DEBURR AND BREAK SHARP EDGES		DO NOT SCALE DRAWING		REVISION 1				
								<p>TITLE: ChareControllerDr awing</p>						
DRAWN		NAME	SIGNATURE	DATE										
CHK'D														
APPV'D														
MFG														
Q.A						MATERIAL:		DWG NO.		A4				
						WEIGHT:		SCALE:1:2		SHEET 1 OF 1				

6 5 4 3 2 1

D

C

B

A

D

C

B

A

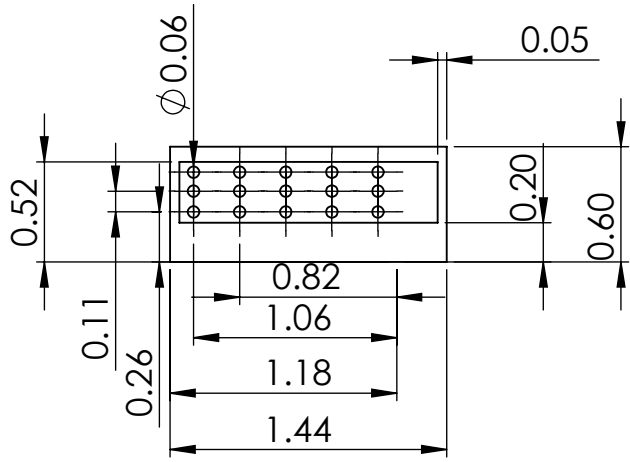
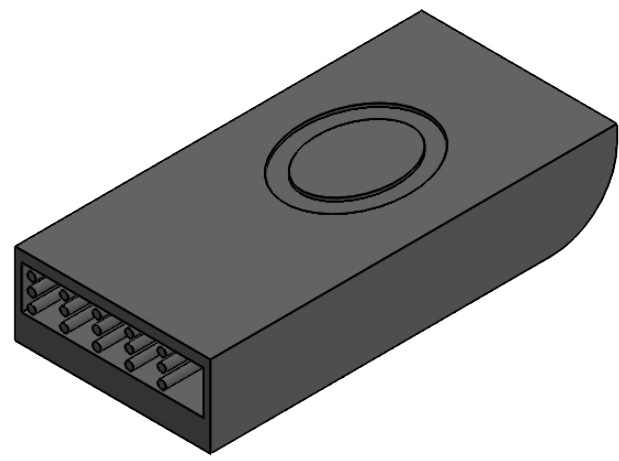
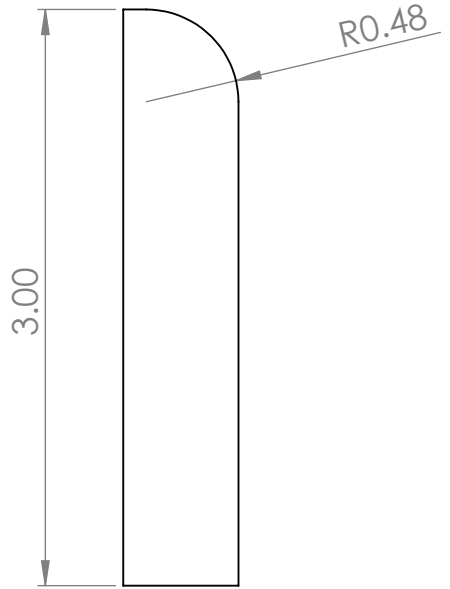
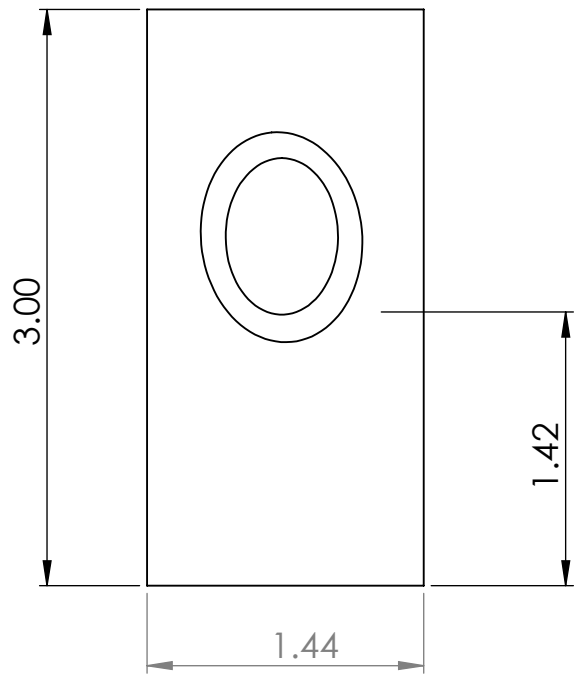

UNLESS OTHERWISE SPECIFIED: DIMENSIONS ARE IN MILLIMETERS SURFACE FINISH: TOLERANCES: LINEAR: ANGULAR:				FINISH:		DEBURR AND BREAK SHARP EDGES		DO NOT SCALE DRAWING		REVISION 1	
DRAWN Mitch				SIGNATURE		DATE 11/23		TITLE: Receiver Drawing			
CHK'D				MFG		MATERIAL:		DWG NO. 10		A4	
APPVD				Q.A		WEIGHT:		SCALE:1:1		SHEET 1 OF 1	

6 5 4 3 2 1

6 5 4 3 2 1

D
C
B
A

D
C
B
A

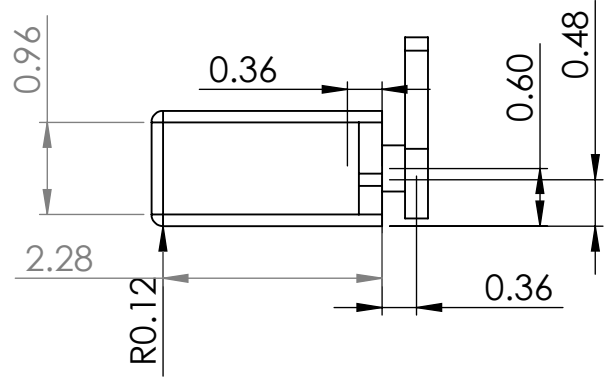
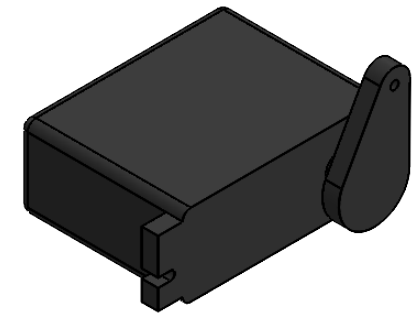
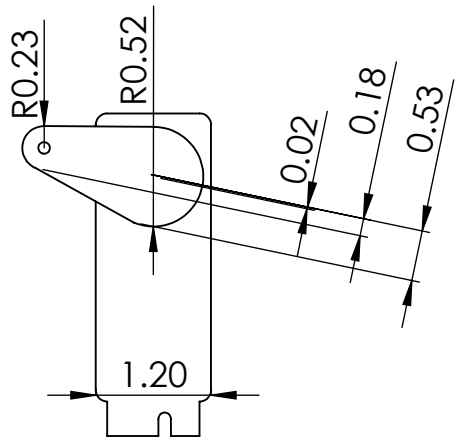
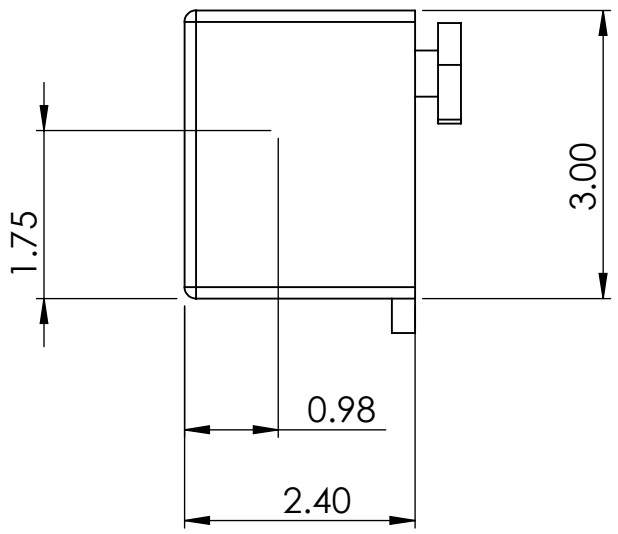

UNLESS OTHERWISE SPECIFIED: DIMENSIONS ARE IN MILLIMETERS SURFACE FINISH: TOLERANCES: LINEAR: ANGULAR:				FINISH:		DEBURR AND BREAK SHARP EDGES		DO NOT SCALE DRAWING		REVISION 1							
						TITLE: <h1>ServoDrawing</h1>											
DRAWN Mitch		SIGNATURE		DATE 11/23								MATERIAL:		DWG NO. 11		A4	
CHK'D																	
APPV'D																	
MFG																	
						WEIGHT:		SCALE:1:2		SHEET 1 OF 1							

6 5 4 3 2 1

4

3

2

1

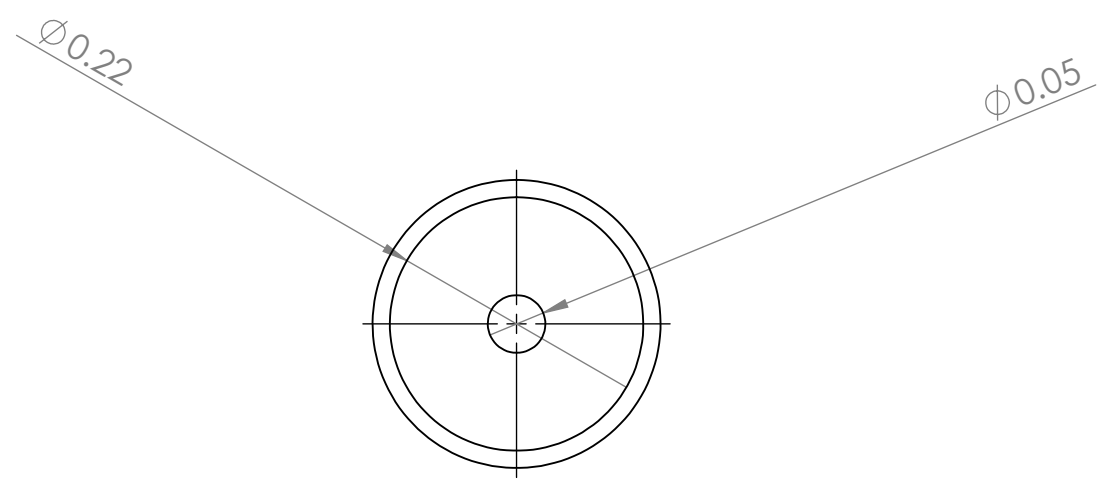
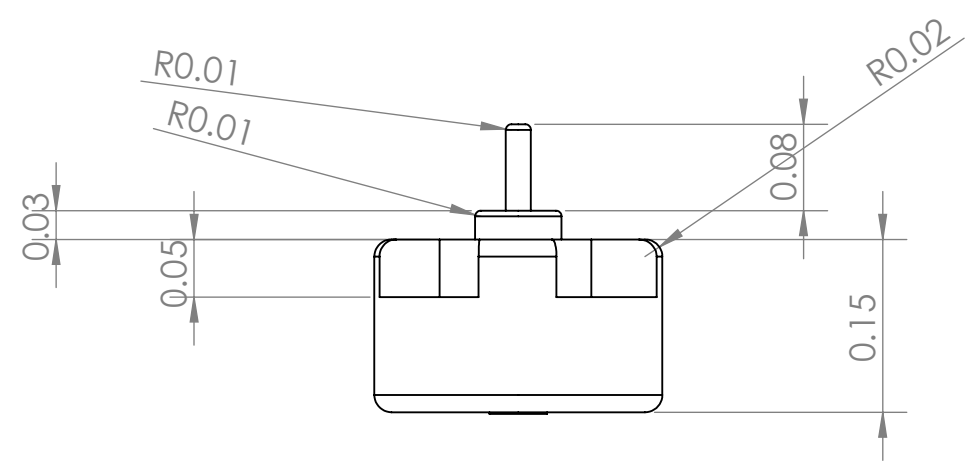
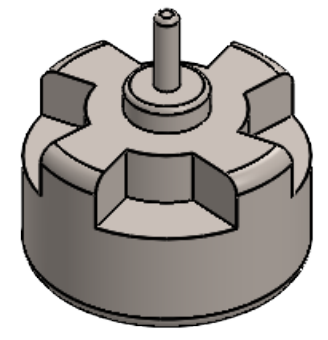
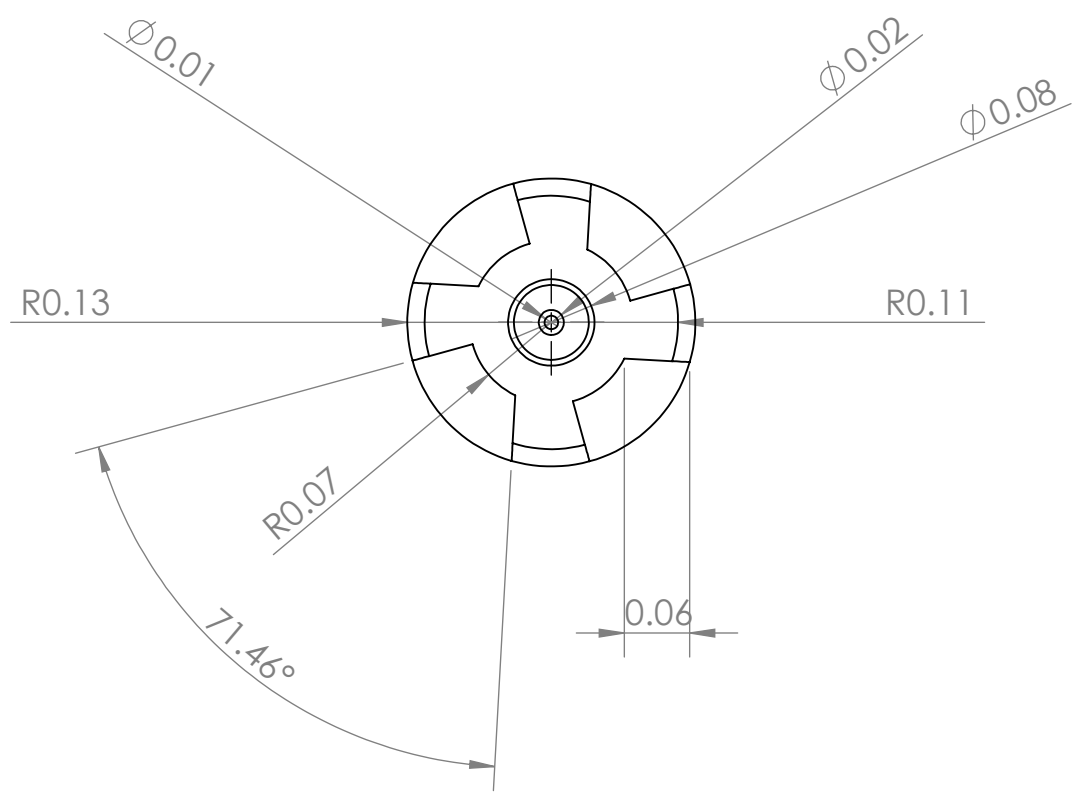

PROPRIETARY AND CONFIDENTIAL
 THE INFORMATION CONTAINED IN THIS DRAWING IS THE SOLE PROPERTY OF TEAM SOL AVEM. ANY REPRODUCTION IN PART OR AS A WHOLE WITHOUT THE WRITTEN PERMISSION OF TEAM SOL AVEM IS PROHIBITED.

		UNLESS OTHERWISE SPECIFIED:		NAME	DATE		
		DIMENSIONS ARE IN Feet		DRAWN	Gage	4/15/22	TITLE: Motor
		TOLERANCES:		CHECKED			
		FRACTIONAL \pm		ENG APPR.			
		ANGULAR: MACH \pm BEND \pm		MFG APPR.			
		TWO PLACE DECIMAL \pm		Q.A.			SIZE DWG. NO. REV
		THREE PLACE DECIMAL \pm		COMMENTS:			
		INTERPRET GEOMETRIC TOLERANCING PER:					SCALE: 1:2 Weight: SHEET 1 OF 1
		MATERIAL					
		Steel					
NEXT ASSY	USED ON	FINISH					
		Polished					
APPLICATION		DO NOT SCALE DRAWING					

3

2

1

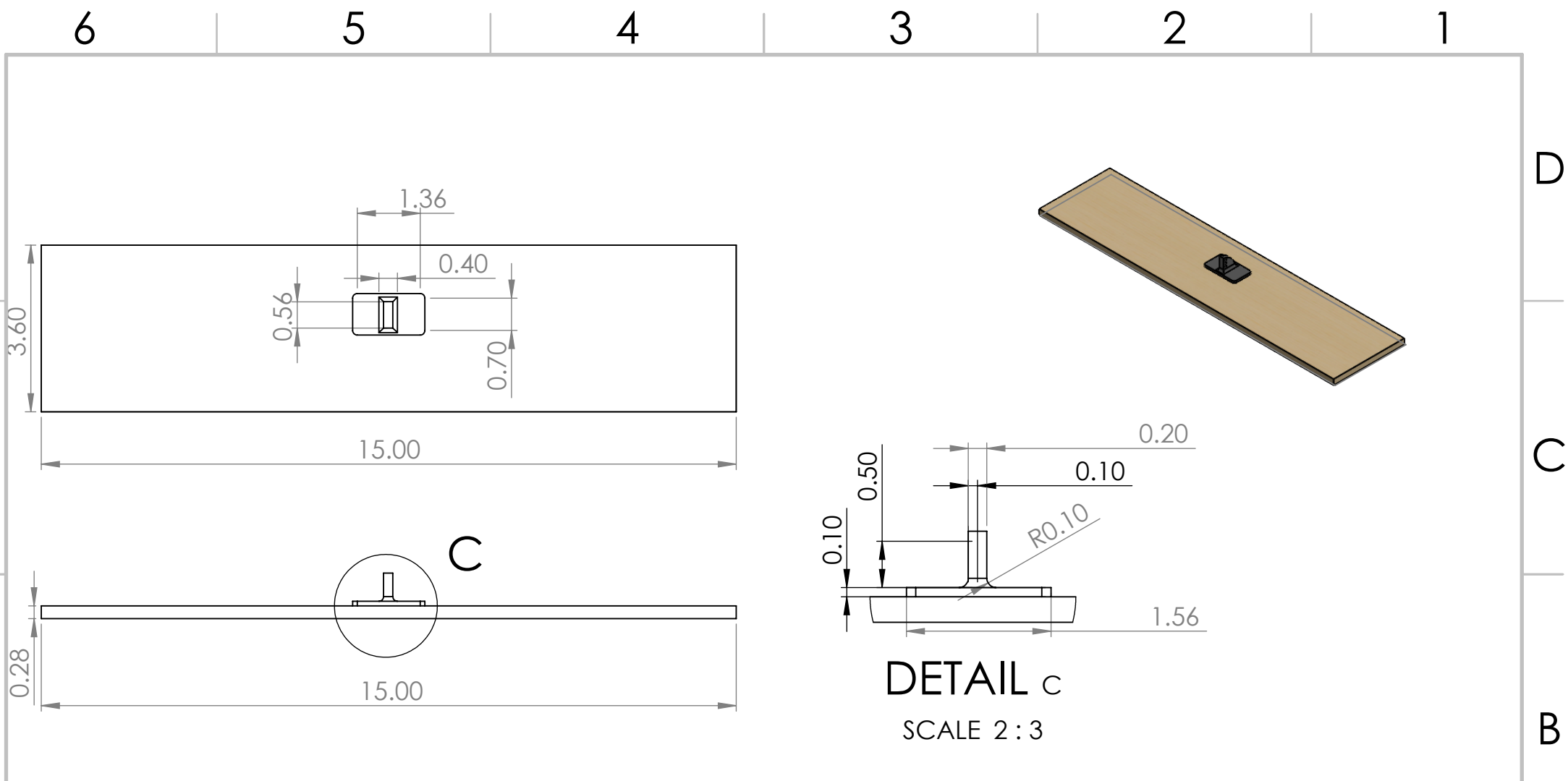

DETAIL C
SCALE 2 : 3

UNLESS OTHERWISE SPECIFIED: DIMENSIONS ARE IN MILLIMETERS SURFACE FINISH: TOLERANCES: LINEAR: ANGULAR:				FINISH:		DEBURR AND BREAK SHARP EDGES		DO NOT SCALE DRAWING		REVISION 1			
								TITLE: AleronsDrawing					
DRAWN		NAME		SIGNATURE		DATE							
CHK'D						11/23							
APPV'D													
MFG													
Q.A								MATERIAL:		DWG NO. 7			
								WEIGHT:		SCALE:1:5			
										SHEET 1 OF 1			
										A4			

6

5

4

3

2

1

D

D

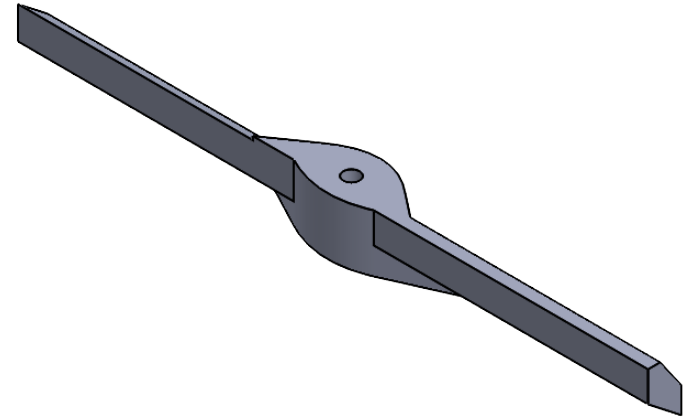
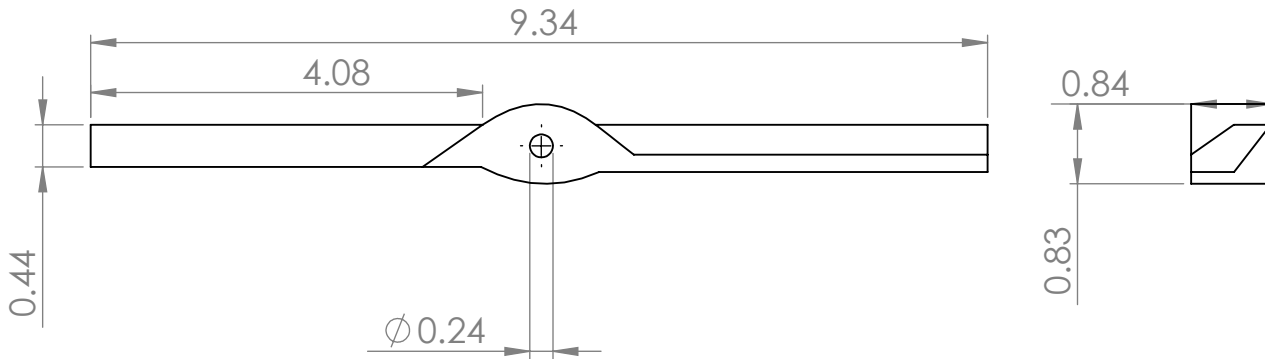

C

C

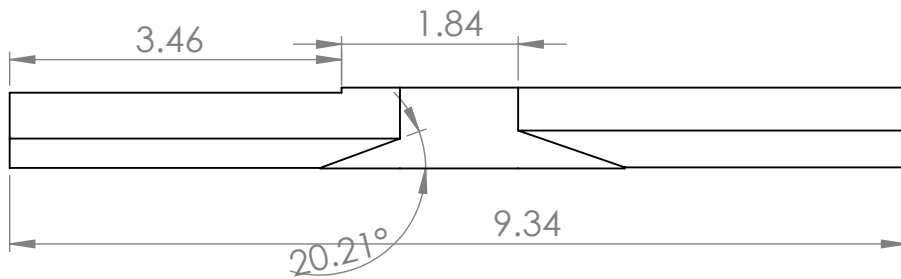

B

B

A

A

UNLESS OTHERWISE SPECIFIED: DIMENSIONS ARE IN MILLIMETERS SURFACE FINISH: TOLERANCES: LINEAR: ANGULAR:				FINISH:		DEBURR AND BREAK SHARP EDGES		DO NOT SCALE DRAWING		REVISION 1	
DRAWN Mitch						DATE 11/23		TITLE: <h1>Propellor</h1>			
CHK'D											
APPVD											
MFG											
Q.A						MATERIAL:		DWG NO. 8		A4	
						WEIGHT:		SCALE:1:2		SHEET 1 OF 1	

6

5

4

3

2

1