

NAU SAE BAJA

Front Suspension

Hardware Status Update - 33% Build

Team 9:
Dylan Wisniewski
Jared Bonds
Zac Biehl



Design Efforts



ITEM NO.	PART NUMBER	QTY.
1	Front End Mock Up	1
2	Part2^Front End Mock Up	1
3	FRONT PASSENGER J ARM	1
4	LOWER PASSENGER A ARM	1
5	Steering Knuckle Final	1
6	FrontHub_V2.1	1
7	Front end brake rotor V4	1
8	HBSBrakeCaliper	1
9	Avacado(half_cut)	10
10	AFCO 63 Shock	1
11	Tie Rod Assembly	1

		UNLESS OTHERWISE SPECIFIED:	NAME	DATE	TITLE: Front End Mock Up SIZE DWG. NO. REV A
		DIMENSIONS ARE IN INCHES	DRAWN		
		TOLERANCES:	CHECKED		
		FRACTIONAL ±	ENG APPR.		
		ANGULAR: MACH ± BEND ±	MFG APPR.		
		TWO PLACE DECIMAL ±	Q.A.		
		THREE PLACE DECIMAL ±	COMMENTS:		
		INTERPRET GEOMETRIC TOLERANCING PER:			
		MATERIAL			
		FINISH			
NEXT ASSY	USED ON	APPLICATION			SCALE: 1:12 WEIGHT: SHEET 1 OF 1

PROPRIETARY AND CONFIDENTIAL
THE INFORMATION CONTAINED IN THIS DRAWING IS THE SOLE PROPERTY OF <INSERT COMPANY NAME HERE>. ANY REPRODUCTION IN PART OR AS A WHOLE WITHOUT THE WRITTEN PERMISSION OF <INSERT COMPANY NAME HERE> IS PROHIBITED.

Figure 1: Front End Mock-Up CAD Drawing

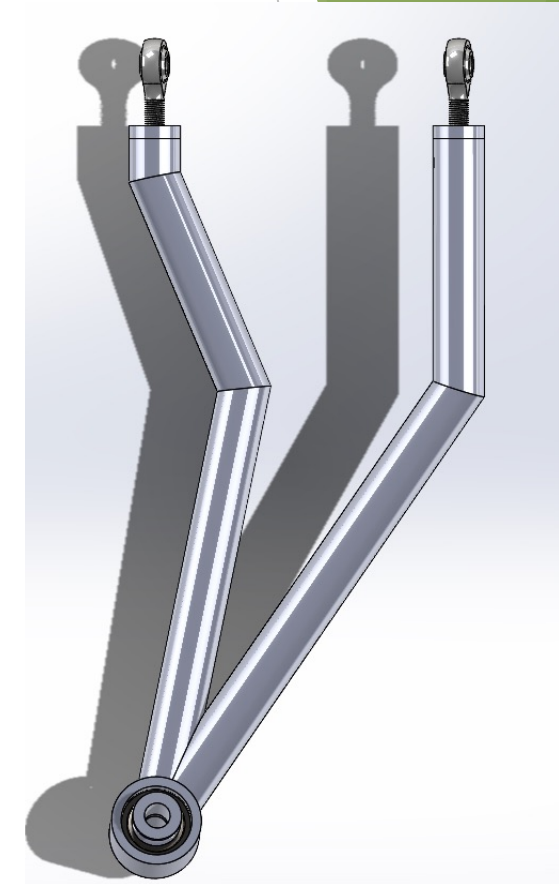

Figure 2: Finalized J Arm

Control Arms



Figure 2: Upper J-Arm Welded



Figure 3: Lower A-Arm Welded

CV Axle Modifications



Figure 4: CV Axle Ends Modified for Sprocket Attachment



Figure 5: CV Axle Modification with Sprocket Drive Mount

Steering Knuckle

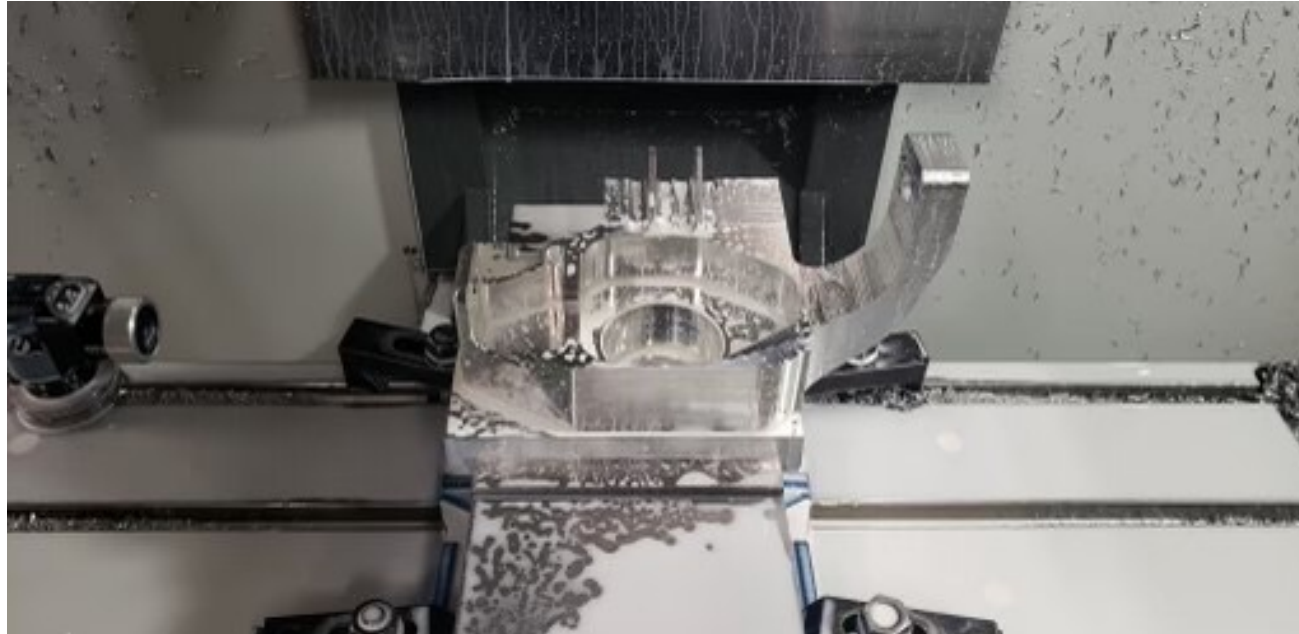

Figure 6: Steering Knuckle in HAAS

Jump to Excel Sheets

Demonstration

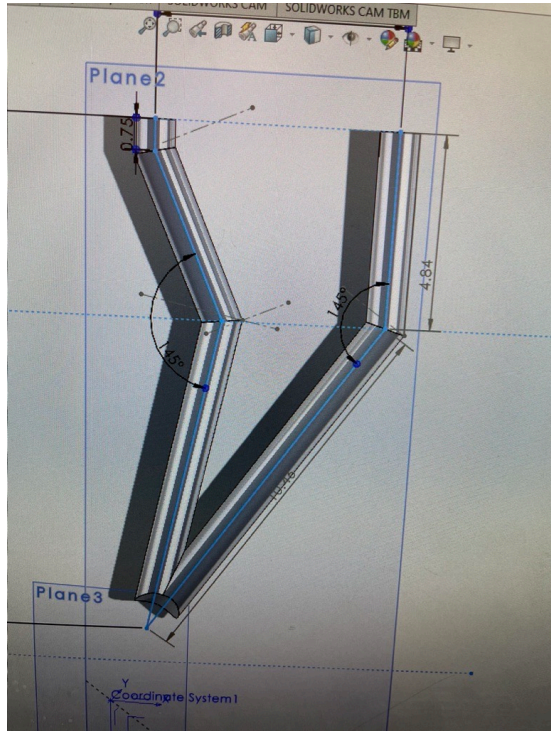

Figure 3: Upper Control Arm

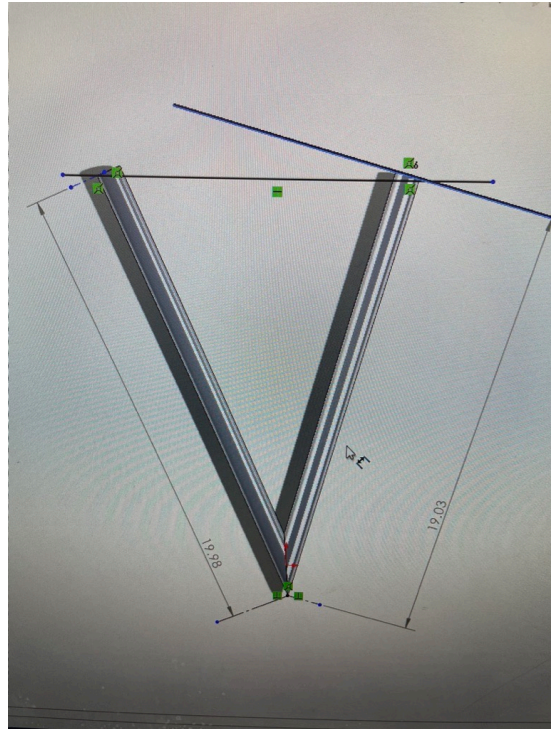

Figure 4: Upper Control Arm Lug



Figure 5: Front Hubs

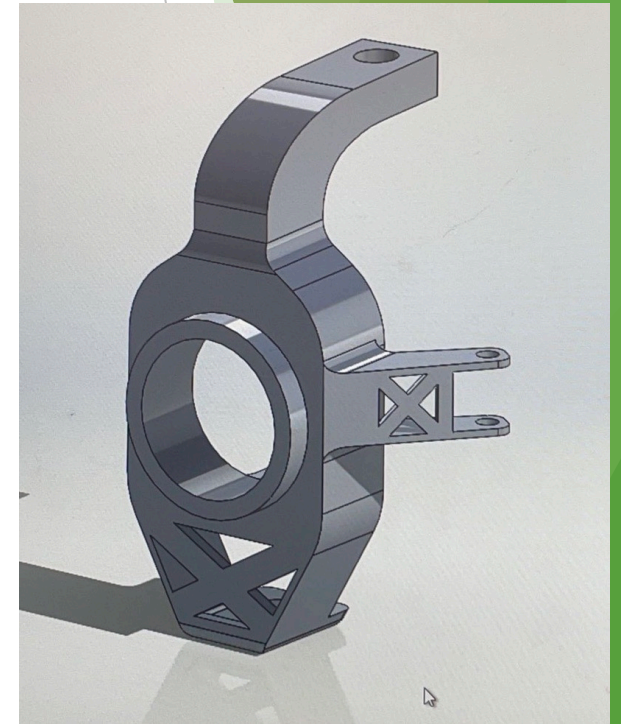

Figure 6: Front Hubs

Questions?

