

# **Salt River Project Team**

## **Final Proposal Report**

**Carl Aaker**

**Ahmad Abuouf**

**Wyatt Bain**

**Tatum Begay**

**Alonzo Bizahaloni**

**Taylor McCormack**

**William Senseman**

**2017-2018**

NORTHERN  
ARIZONA  
UNIVERSITY



*College of  
Engineering, Forestry  
& Natural Sciences*

**Project Sponsor:** Salt River Project

**Faculty Advisor:** Sarah Oman

**Sponsor Mentor:** Kyle Yamamoto

## **DISCLAIMER**

This report was prepared by students as part of a university course requirement. While considerable effort has been put into the project, it is not the work of licensed engineers and has not undergone the extensive verification that is common in the profession. The information, data, conclusions, and content of this report should not be relied on or utilized without thorough, independent testing and verification. University faculty members may have been associated with this project as advisors, sponsors, or course instructors, but as such they are not responsible for the accuracy of results or conclusions.

## EXECUTIVE SUMMARY

On the Navajo Nation there are around Twenty-thousand homes off the grid. With these off-grid homes, they need some way to heat their homes, forcing them to rely on other heating sources such as coal, propane, and wood burning. These heating methods are unsafe and cause a health hazard by releasing toxic smoke. Salt River Project (SRP) gave our team the task of finding a safer and cleaner means to providing heat to these households. For this project SRP wants to utilize renewable resources to combat the issue of toxic smoke. The objective is to find out whether a solar thermal air heater can be paired with phase change material (PCM) to provide clean and efficient heating over the course of any night during the year. The PCM is a material that goes through a phase change process, as it heats up and melts, it stores energy and when the temperature drops it releases that energy to keep the ambient temperature the same. The goal is get the Solar Air Heater to operate during the day that would distribute warm air throughout the home and at night the PCM would release excess stored energy to keep the home warm. Over a couple of months, the team did extensive background research on solar heating systems, solar power, PCM, insulation, coils, batteries, and green rhino system. Using the data, we collected 11 concept designs were created to solve the problem at hand. For the design selection process several customer requirements were looked at, such as low cost, ease of use, light weight, and efficiency. After the selection process a design was chosen that meant all specifications and requirements. The chosen design is a vertically heated box with heat circulation, control system and secondary heat source. The design features a solar air heater attached to a heavily insulated box containing the PCM. Throughout the day the box will charge a battery via solar panels to run fans. These fans will circulate the cold air from the house, through the solar panel and re-distribute warm air back through the house. At night the energy stored in the PCM will be released to keep the home warm. Since some homes on the Navajo Nation have little to no insulation many sheets of PCM are required to counteract the heat loss. This design was the best choice because once the phase change material starts to lose energy a battery powered secondary heating source will start providing extra energy to the system to keep the home warm. Through this the design, the team hopes to help SRP provide a low cost, clean and effective way to heat homes in the nation. Future work for the project has been created due to testing through simulations for peak performance and presenting our findings to SRP.

# TABLE OF CONTENTS

## Contents

DISCLAIMER .....	ii
EXECUTIVE SUMMARY .....	iii
TABLE OF CONTENTS .....	iv
1 BACKGROUND .....	1
1.1 Introduction .....	1
1.2 Project Description .....	1
2 REQUIREMENTS .....	2
2.1 Customer Requirements (CRs).....	2
2.2 Engineering Requirements (ERs) .....	3
2.3 Testing Procedures (TPs).....	4
2.3.1 Testing Ease of Use (1) .....	4
2.3.2 Testing Simplicity of Design (2).....	4
2.3.3 Ensuring Low Cost (3).....	4
2.3.4 Testing Safety (4).....	4
2.3.5 Testing Efficiency to Replace Current Heating (5).....	5
2.4 House of Quality (HoQ) .....	6
3 EXISTING DESIGNS .....	7
3.1 Design Research .....	7
3.2 System Level .....	8
3.2.1 Existing Design #1: Tube Type Solar Air Heater .....	8
3.2.2 Existing Design #2: Screen Type Solar Air Heater .....	8
3.2.3 Existing Design #3: Back Pass Solar Air Heater .....	9
3.3 Functional Decomposition.....	10
3.3.1 Black Box Model .....	10
3.3.2 Functional Model/Work-Process Diagram/Hierarchical Task Analysis.....	11
3.4 Subsystem Level.....	12
3.4.1 Subsystem #1: Back of Panel Material Type .....	13
3.4.2 Subsystem #2: Insulating Cover for Device.....	13
3.4.3 Subsystem #3: Phase Change Material .....	14
4 DESIGNS CONSIDERED .....	15
4.1 Design #1: Vertically Heated Box with Removable PCM.....	15
4.2 Design #2: Wall Integrated PCM with Roof Mounted Heating Unit.....	15
4.3 Design #3: Door-Replacing Heat Box with Fan.....	16
4.4 Design #4: Wall-Mounted Constant Heating Device.....	17
4.5 Design #5: Switch-Based Ducted Heating Storage .....	17
4.6 Design #6: Separate Air Heater and Moveable Cylinder Heater with Weight-Driven Fan ....	18
4.7 Design #7: Separate Wall-Mounted Air Heater with Duct-Work and Moveable Trapezoidal Heater.....	19
4.8 Design #8: Roof Mounted Air Heater with Arduino Controlled Fan and Door Top Mounted Duct-Work .....	20
4.9 Design #9: Beehive-like PCM Slat and Movable Solar Air Heater.....	21
4.10 Design #10: Moveable Cylinder Home-Heater with Automatic System/LCD battery display and Solar Heater Station .....	22
4.11 Design #11: Vertically Heated Box with Heat Circulation, Control System, and Secondary Heat Source.....	22
5 DESIGN SELECTED – First Semester.....	24
5.1 Rationale for Design Selection.....	24

5.2	Design Description .....	26
5.2.1	Final Design Selection .....	26
5.2.2	Dimensions of The Final Design.....	27
6	PROPOSED DESIGN – First Semester .....	28
6.1	Implementation Plan.....	28
6.2	Schedule .....	28
6.3	Budget Proposal.....	30
7	REFERENCES .....	31
8	APPENDICES .....	32
8.1	Appendix A: House of Quality (HoQ).....	32
8.2	Appendix B: Pugh Chart.....	33

# **1 BACKGROUND**

For this project, our team was tasked with designing a heater that utilizes both solar heating and phase change material (PCM) for the Navajo Nation. Currently, many homes on the Navajo Nation is off the grid and to heat their homes, residents are using unsafe systems such as burning coal, wood, or propane. Salt River Project (SRP) approached us with this project to provide a safe and clean means to heat Navajo homes during the colder months of the year.

## ***1.1 Introduction***

Salt River Project is a community-based nonprofit utility that has been serving central Arizona since 1903. They are the oldest multipurpose federal reclamation project in the United States and currently are the largest provider for both electricity and water in the greater Phoenix metropolitan area.

Salt River Project has partial ownership of the Navajo Generating Station located near Page, Arizona and have developed strong relations with the Navajo Nation. During several months out of the year, northern Arizona can reach below freezing temperatures. Due to homes that are off the grid, conventional means of heating are impractical, so residents must rely on other alternatives for heating such as burning coal, wood, or propane. Over 20,000 homes on the nation utilize these heating sources which are both a fire hazard and bad for health. The goal of this project is to reduce or eliminate these fuels burning methods by using renewable resources.

The SRP capstone team was approached with the idea of pairing both solar heaters and PCM to efficiently heat these homes during the harsh winter months. The final product should be able to heat a home during the day while storing the excess heat into the PCM, which will be used later in the evening and throughout the night. Through research, the team will be accumulating data on weather patterns, home constructions, and energy consumption on the reservation. From this data, SRP would like us to achieve an understanding of how much PCM needs to be paired with a solar heater to effectively heat these homes. For this project, a company named SolarThermiX, based out of Tempe AZ, will be providing a solar heater and PCM to be used during the project.

## ***1.2 Project Description***

The following is the original project description provided by the sponsor:

“The project will examine the effectiveness of pairing phase change material (PCM) with solar air heaters to heat homes on the Navajo Nation. At the end of the capstone we hope to understand the best configuration of PCM and a solar air heater needed to sufficiently heat a home. The project scope includes research of Navajo climate and home construction, modeling home energy consumption for heating, estimating the required quantity of PCM to pair with the solar air heater, designing how the PCM and solar air heater would be configured, building a small scale prototype, testing the design, and evaluating the performance.”

## 2 REQUIREMENTS

The following requirements were created from the project description provided by SRP. Research was conducted on modern Navajo hogans to complete the customer requirements (CRs). The customer requirements are assigned an objective to be met. From the CRs, engineering requirements (ERs) can be constructed with an assigned target and tolerance values. The House of Quality (HoQ) is shown in Table 5, and is also included in Appendix A.

### 2.1 Customer Requirements (CRs)

The following CRs are defined by SRP, the sponsor of the project. The solar air heater is to be designed for Navajo families that live off the grid. The list of CRs are weighted based on the significance of the requirements to the final design. The weight of the CRs are out of a total of 63.

As a team, the CRs were developed by the using the project description provided by the sponsor. The sponsor specified a low cost and easy to use system for the project. For a low-cost design, the team decided to have a simple design to minimize the maintenance. Safety was a top concern as the solar air heater is inside the home, so the team made safety a 9 out of 63. The efficiency is also a top concern as the project is aimed to replace wood and coal sources of fuel. The size was rated a 5 out of 63 for having the design to be able to be placed on a wall of a hogan. The aesthetics was given a low rating, because the design does not depend on the aesthetics of the design.

*Table 1: Customer Requirements*

<b>Customer Requirements</b>	<b>Weight (Total = 63)</b>	<b>Rationale</b>
Ease of Use	9	Ensures that the solar air heater can be operated and maintained by the average consumer.
Simplicity of Design	9	The simplicity of the design would reduce costs for prototyping and testing.
Low Cost	9	By having a low cost, this ensures that Navajo families can heat their home safely and can be accessible to everyone.
Safety	9	This ensures that the PCM would not put the contents of the home at risk for fires or damages.
Efficiency	9	Shows how much energy the solar air heater can produce and how much energy can be converted to heat the home.
Size	5	The size of the SolarThermiX STX 7000 is 4x8x2 ft. and must be able to be place outside the home.
Aesthetics	4	The overall design must fit the client's needs and blend within the desert landscape.

## 2.2 Engineering Requirements (ERs)

The following ERs are measurable parameters of the listed CRs. Each ER has a target value along with a tolerance value that each requirement must meet in the final design. A rationale of the ERs is also provided.

As a team we determined the engineering requirements based on the design, the user of our product, and the purpose of our product. The first requirement we came up with was the ease of use, which is the most important because we want everyone to be able to use our product despite the education level. Size and weight requirements were dependent on the manufacturer specifications. Cost was another requirement because we want this to be more affordable to the masses. Heat absorption, heat storage, and flow of energy are requirements based on assumptions of our materials. We decided these were requirements based on efficiency of the products we are using such as solar air heater and PCM. Lifespan requirement is a requirement based on the lifespan of materials that made up our product. Maintenance is our final requirement which based on normal repairs that might be needed due overheated fans, or damage caused by weather.

Table 2: Engineering Requirements

Engineering Requirements	Target	Tolerance	Rationale
Size	4x8x2 ft.	+10 cm.	To maximize the dimensions of the SolarThermiX STX 7000 solar air heater.
Cost	\$2,000 dollars	+200 dollars	The allowance given by SRP. The cost of design, prototyping, and testing should not exceed \$2,000.
Weight	50 lbs.	+10 lbs.	To be able to safely lift the PCM off the SolarThermiX heater and bring inside the home.
Heat Absorption	73° to 80° Fahrenheit	-3° Fahrenheit	PCM must be able to heat up the home within this temperature range.
Ease of Assembly/Installation	≤2 hours	-1 year	Assembly of the solar air heater and placement of the PCM should not exceed 2 hours.
Lifespan	10 years	-1 year	The solar air heater and PCM must have a lifespan of 10 years as specified by SolarThermiX.
Heat Storage	8 hours	-1 hour	PCM must be able to heat up the home for at least 8 hours.



Flow of Energy	7.9 MJ/hr.	-2,000 KJ/hr.	The flow of energy specified by SolarThermiX STX 7000.
Maintenance	\$300 dollars	+\$200 dollars	The cost of repair of the solar air heater or replacement of the PCM should not exceed \$300.

**2.3 Testing Procedures (TPs)**

To ensure that the engineering requirements are met, testing procedures are developed to test each parameter. Each TPs are numbered in correspondence to the number in the House of Quality (Appendix A). TPs are required to ensure that each ER is within the tolerance values shown in Table 2.

**2.3.1 Testing Ease of Use (1)**

Testing ease of use will ensure that the team’s design is being assembled with an easy to read manual. The design will have interchangeable parts that can be easily maintained. The team will test this by taking our manual and letting people outside of engineering background review the manual. The team would ask if they understand the manual, if there is confusion, the team can clarify any confusion in the manual.

**2.3.2 Testing Simplicity of Design (2)**

To test the simplicity of the design, the design will have a minimum number of parts that will have to be assembled. The manual will have a written description along with a picture description of the assembly. Testing this we will have a poll for the consumer testing and after they read the manual and put together our product we will ask them a series of question such as based on the manual how easy was it to build our product? Another question would be, is there any confusing parts to the manual? Please provide feedback if you answered yes to any of the above questions.

**2.3.3 Ensuring Low Cost (3)**

The sponsor provided a budget to cover all cost associated with the project. Since the sponsor wanted a low-cost design, the team choose parts for the project that is under \$100 dollars as seen in Table 6. If the consumer were the replace parts, the parts can be maintained for under \$300 dollars. To test this, we would do market research System Advisory Model (SAM) to ensure accurate parts that would be affordable for minimum income housing.

**2.3.4 Testing Safety (4)**

To ensure that the team’s design is safe, the team picked materials that can suffice the temperatures within the operating range. According to the manufacturer, the PCM has a stopping point at 73 degrees Fahrenheit, any temperature above this makes the PCM release the heat inside. The manufacturer also specified that the PCM is non-toxic and if the PCM were to leak, it would not harm the person handling the material. To test the safety requirement, we will push the limits of materials and testing the manufacturer specifications according to their datasheets on the materials found online.

### **2.3.5 Testing Efficiency to Replace Current Heating (5)**

To test the efficiency of the team's design, a computer simulation will be modeled on EnergyPlus software. If the tests failed to withstand the CRs and ERs, changes to the design will be retested on EnergyPlus.

## 2.4 House of Quality (HoQ)

The following section contains the House of Quality (HoQ) developed by the CRs and ERs. The CRs are given a weight and are then transformed to ERs. The ERs are then assigned to target and tolerance values. These values can be seen in the HoQ. The HoQ has helped to team to decide what aspects of the design to concentrate on in order to complete all of the requirements. The HoQ can be seen in Table 3 or in Appendix A. According to the HoQ, heat absorption, heat storage, maintenance, and the weight of the solar heater are the four factors that the team must focus on.

Table 3: House of Quality (HoQ)

		Technical Requirements								
	Customer Needs	Customer Weights	Size	Cost	Weight	Heat Absorption	Ease of Assembly	Lifespan	Flow of Energy	Maintenance
1	Ease of Use	9	9	1	9	3	3	3	3	3
2	Simplicity of Design	9	9	3	1	3	9	9	3	9
3	Low Cost	9	3	9	1	9	9	3	9	9
4	Safety	9	9	3	9	9	9	9	9	9
5	Efficiency to replace current Heating	9	9	9	9	9	3	3	9	3
6	Manageable Size	3	9	9	9	3	9	3	9	9
7	Aesthetically Pleasing	3	1	1	1	1	1	1	1	1
	<b>Technical Requirement Units</b>		Cubic Feet	Dollars	Pounds	kiloJoules	Minutes	Years	Joules per Feet per Second	Dollars
	<b>Technical Requirement Targets</b>		96	2000	<100	2000	20	>10	20	200
	<b>Absolute Technical Importance</b>	381		255	291	309	327	255	327	327
	<b>Relative Technical Importance</b>		1	5	4	3	2	5	2	2

## 3 EXISTING DESIGNS

There are numerous variations of existing designs that utilizes solar air heaters to heat a home. The research begins at investigating different solar air heaters and several types of PCM. After the team understood how the materials functioned, the scope was narrowed down to system levels. This section also includes functional decomposition and subsystem levels.

### 3.1 Design Research

Initial research started with the materials that were donated by SRP. The team investigated the design and layout of the SolarThermiX STX 7000 Solar Air Heater. The team was also able to get into contact with SolarThermiX. They provided us with information that was related to the details and design that they measured up to one ton of carbon mitigated per year using their heater. [1] This simple design has a solar panel 4-foot by 8-foot unit onto exterior wall of a house at 90 degrees that uses a six-inch hole in diameter at the bottom of the unit. This solar air heater uses the concept of absorption to warm up the air that is pushed by a fan. The AC transformer that passes through the enclosure heating up, then placed back into the home thru another 6-inch diameter hole back into the house. According to the company, this unit should heat up to 1,000 square feet at 70 degrees through an output of 7,000 BTU's per hour [1]. The estimated price is around \$1,500 per unit.

The following material that we researched was the InfiniteR PCM, also donated to the team by SRP. The company that manufactures this PCM is Insolcorp. According to the company's website, InfiniteR PCM is described as, "ice inside a cooler, slowly melting or thawing to maintain a target temperature using the process of phase change [6]". This material combined with the solar air heater could provide a comfortable and safe environment while reducing emissions and increasing energy efficiency. The PCM is made out of clay, salt water, and a gelling agent. The PCM has multiple temperature ranges when the material starts to dissolve at certain temperatures which we are currently looking at 73 degrees Fahrenheit. The size dimension for this PCM is a mat variation that is measured 2 foot by 4 foot of the exact model number, 23C M100. The PCM price estimation is \$3 per square foot.

Other researched PCM products by companies have multiple PCM's. The PCM by manufacturer have some PCM's that are designed for specific subzero weather to high temperature weather. The subzero eutectic degree range goes from 32 degrees Fahrenheit to -173 degrees so this particular material holds a specific heat capacity anywhere between 0.992 to 0.566 BTU's per pound Fahrenheit. Whereas, the Hydrated Salt material has a temperature range from 45 degrees Fahrenheit to 243 degrees Fahrenheit and holds a specific heat range between 0.203 to 0.405 BTU's per pound Fahrenheit. "When the material freezes, it releases large amounts of energy in the form of latent heat of fusion, or energy of crystallization, PCM can be used in a number of ways, such as thermal energy storage whereby heat and coolness can be stored for a period of time." [7] These eutectics tends to be a solution of salt in water for temperatures below freezing without crystallization.

The other solar air heater the team researched was SolarSheat 1000GS PV-DC. The cost of the system is \$1,349. The SolarSheat system includes an air collector, a 20-watt PV panel, thermostat, fan, collars, filter, sensors, gaskets and snap lock duct. According to the company website, "The SolarSheat 1000GS is a self-powered solar air collector that can deliver space heating for up to 400 square feet [9]". To install the system in the house, a six-inch grill is attached to the intake of the inside the home. On a clear sunny day, this system puts 9,900 BTU's per day, and the fan is a solar electric PV panel which generates 14.5 watts. The CO2 reduction is estimated at .18 tons per year. This huge panel is 12ft by 9ft with a total weight to of 68 lbs. This system is made out of aluminum, tempered glass, and PV panel and can also heating up your home to 90 degrees Fahrenheit.

### 3.2 System Level

As stated in prior sections the team is required to heat up a hogan on the Navajo reservation. The products we will be using are solar air heaters and PCM. The team’s task will be combing these two products in order to heat the hogan during the day as well as at night. However, after much research the team didn’t find any products that combined the two together. Each heating system that used solar air heaters only incorporated solar air heaters itself. This section will be describing three different types of solar air heaters that are currently being used. These air heaters are the back pass, tube type, and screen type air heaters. Each one of these heaters have the same principles when it comes to heating the air coming through it but each one incorporates different types of materials and components in order to do so.

#### 3.2.1 Existing Design #1: Tube Type Solar Air Heater

The tube type solar air heater is a solar air heater that incorporates aluminum tubes that will be able to heat the air that will be flowing through it. Many people, however, have been known to use aluminum cans rather than actual aluminum tubing. It’s the same concept as other solar air heaters the air will come in flow through the aluminum cans/tubes, these should be able to produce heat as it comes out from the top. The cans/tubes can be oriented in certain ways in order to have the airflow continue longer in order to generate more heat within the air. To better understand how this process works refer to Figure 3.

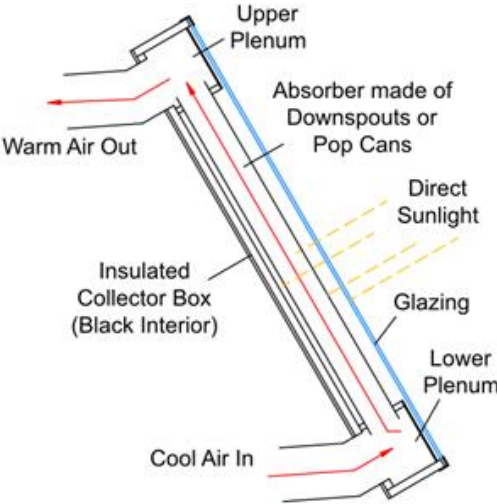

Tube Type Solar Air Collector

Figure 1: Parts of a Tube Type Solar Air Heater

#### 3.2.2 Existing Design #2: Screen Type Solar Air Heater

The screen type solar air heaters have the same concept as the back pass solar air heaters, however, they don’t incorporate an aluminum sheet that will absorb the heat. The screen type use a screen that absorbs the heat and that is what generates hot air. The cold air comes in from the bottom of the heater and as the cold air flows through the box the screen absorbs the sunlight and produces heat and it converts the cold air into hot air and that is blown out through the top of the box. This design is another cheap version of

solar air heaters due to the materials that are being used within the system. To understand the concept better refer to Figure 2 for a visual representation. This design will meet the requirements of heating the hogan and the PCM material that will be used at night.

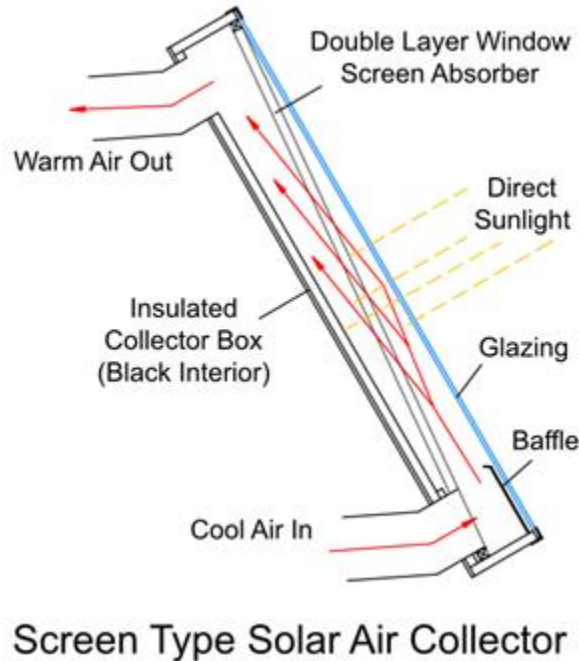
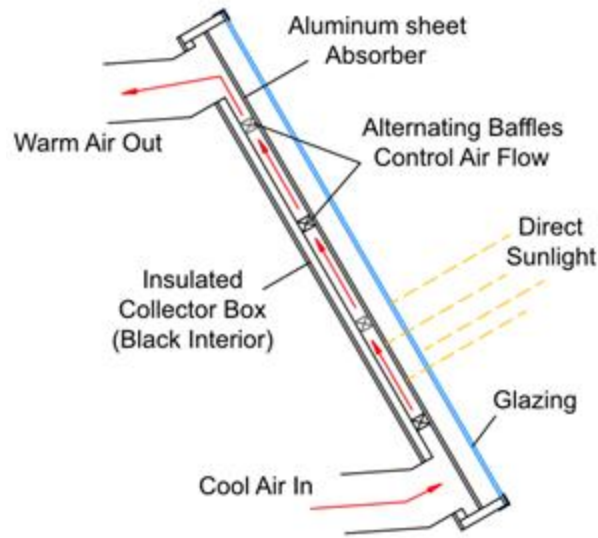

Figure 2: Parts of a Screen Type Solar Air Heater

### 3.2.3 Existing Design #3: Back Pass Solar Air Heater

The Back Pass Solar air heater is a pretty basic concept when it comes to heating air. The main concept is heating the cold air coming in using a solar heat absorber. Cold air comes in from the bottom of the heater and as the air flows through the device, it is slowly being heated by the solar heat absorber within the box. This heat that has been produced is then pushed out from the top producing heat for a fully understand how this air heater works please refer to Figure 1. home. This design is the most basic when it comes to solar air heaters, in order to reduce cost and make the product easy to operate the team may look into using this solar air heater technology. This current design relates to our project requirements because it will be heating the hogan during day and the PCM.



**Back-pass Solar Air Collector**

*Figure 3: Parts of a Back-pass Solar Air Heater*

### **3.3 Functional Decomposition**

The functional decomposition of the solar air heater is demonstrated by the black box model and functional model that shows how the solar air heater functions. The black box model displays the inputs as the solar energy and the output is the heat leaving the solar box that has been created by the solar box. The system is controlled by a thermostat which allows the user to turn on and control the temperature on the system within the house. The output is the mechanical aspect of the system pushing the warm air out by a fan in the solar air heater system.

#### **3.3.1 Black Box Model**

The black box model is a visual of the inputs and outputs of the solar air heater. The inputs of the solar air heater box capture solar energy heat which then comes out of the system by the dial of the thermostat.

The functional model is an integral encapsulate of this project since it maps out the inputs and outputs of the solar air heater. The inputs of the solar air heater black box includes solar light, on/off heating, and elect Human. The designated output includes heat output, mechanical heat output, and the heat output of the on/off switch. The solar heat output can only be experienced when the thermostat is dialed. The purpose of the solar heater box is to absorb the solar heat.

The solar heater box is mechanically modeled to allow air to enter from one corner and exit from another. The box is painted black to increase its absorbance and retention of solar heat. Maximum efficiency can be achieved by insulating the box to prevent heat from escaping through the process of conduction. The solar heater box is also covered by tempered glass which is a material that is resilient to heat and very strong which ultimately secures the box.



Figure 4: Black Box Model of the Solar Air Heater

### 3.3.2 Functional Model/Work-Process Diagram/Hierarchical Task Analysis

The functional model of the solar air heating system, is shown Figure 5. It is a comprehensive depiction of the mechanical and electrical steps that would occur in the process of heating the home using solar energy. The system works in several stages. The system begins when the solar air heater panels captures the light, which then is converted into heat. The air that cycles throughout the house is vacuumed by an air filter and goes into the solar box to be heated. The pre-installed fans in the solar air heater then pushes the warm air into the house.

Figure 5 will be pivotal for this project since it partitions the entire system into segments making it easier to understand the entire system. The objectives to be achieved at every stage is clearly outlined. The diagram can also be used as the basis for the formulation of recommendations that can better the efficiency and usability of the system. The recommendations can be targeted to improve the functionality of a aspect of the system. The model also makes it easier to pinpoint design flaws in the system.

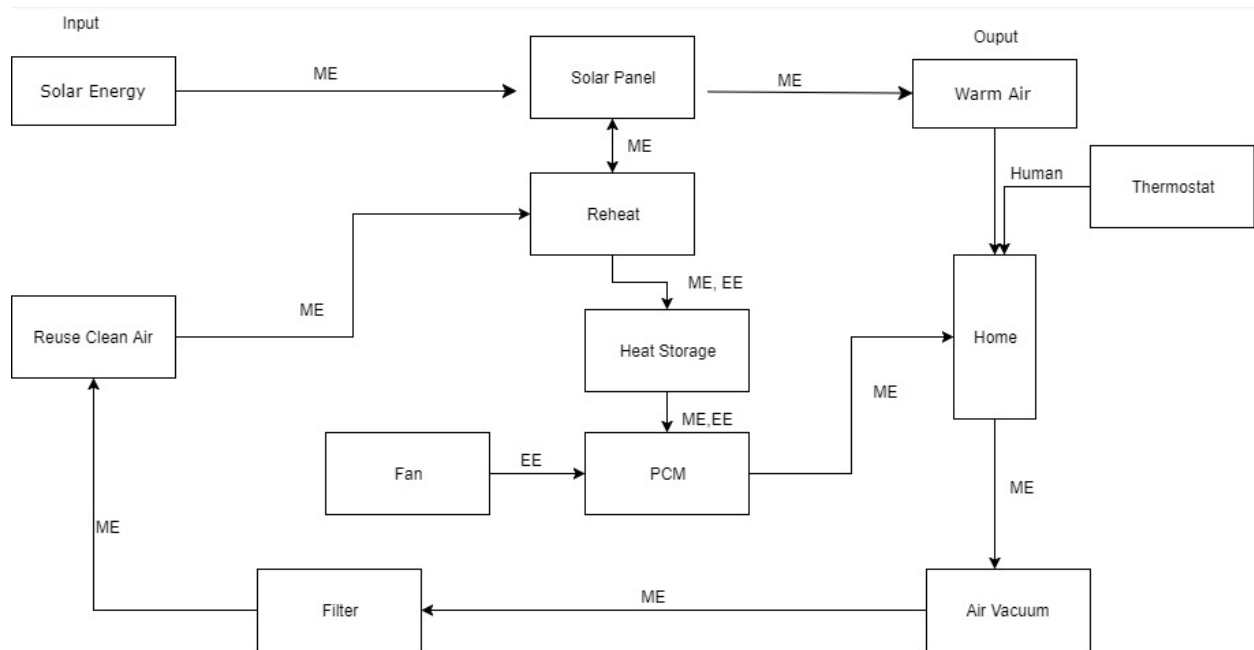

Figure 5: Functional model of the Solar Air Heater System



Figure 5 is a workflow diagram that captures the work process in the design. The diagram addresses factors that may impact the design and production processes of the solar air heater. Such processes include funding and market players. Figure 5 captures flow of work in the development of the solar air heater, the role of SRP team, and how a client prefer heat storage for nighttime use. Materials to be procured, such as SolarThermiX are also included. Holistically, the diagram represents the implementation phase of the project.

In Figure 6 is vital for the project since it elucidates fundamentals points of consideration that implements the phase of the project. The diagram presents team members with a holistic understanding of the role of suppliers, clients, and the SRP team in the implementation of the design and establishment of a satisfactory solar air heater system that serves the needs of the target group.

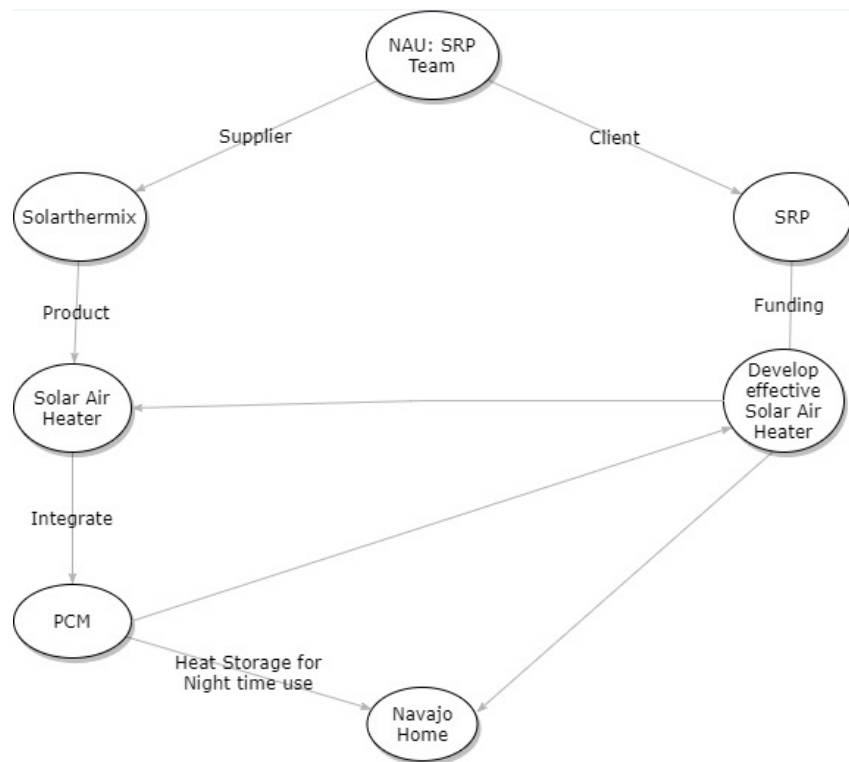

Figure 6: Workflow Diagram for NAU SRP Team

### 3.4 Subsystem Level

Each subsystem details the different means of harnessing the most heat between the cold air intake to the hot air exhaust. The main components that were different in each existing type of thermal panel were the dark material used to capture and/or absorb the sunlight.

### **3.4.1 Subsystem #1: Back of Panel Material Type**

The main difference in all three of the existing designs is the type of material that is used in order to capture the heat from the sun and contain it in the solar thermal air heater. This is important to the project because the type of material depends on the thermal heating of the air as it passes through the heater. Another reason that this subsystem is important is that each different material has a varying level of longevity, and since the system is supposed to last for 10 years in good conditions, the material chosen in the final design will be optimized.

#### **3.4.1.1 Existing Design #1: Aluminum Tubing**

This first design implements aluminum tubing either in the form of proper aluminum tubing or aluminum cans with a black painted coating. This design is effective in terms of keeping heat, but in terms of longevity, which is the tightest constraint, the aluminum can design most likely uses a low end of black paint and thus would peel and prove ineffective in a few mere years. In terms of producing a sufficient heat flow, the design would also fail this requirement because of the peeling paint.

#### **3.4.1.2 Existing Design #2: Black Background and Absorbing Mirror**

This design reflects the incoming light from the sun into a mirror and then reflects it and builds up heat and captures the remaining heat into a black background of the panel. This idea can be good assuming the absorbing mirror reflects some of the light. The only drawback to this design is the potential that the plastic that insulates the device can fade due to the UV lights that it soaks in almost every day. In terms of the heating, this device can produce much heat and should be able to meet the requirements stated in the engineering requirements.

#### **3.4.1.3 Existing Design #3: Alternating Baffle Design**

This design intakes the cold air and then uses baffles in order to wind the air around so that it slows down the flow of the air and gives the air a chance to heat up more evenly and fully. The advantage in this design is that the baffle design provides a more efficient route for air to take so that it can provide much hotter air at top of the design. In terms of longevity, the fact that the baffles are metal and thus they can last much longer due to lack of paint. The black absorbing back of the device would be the only concern depending on the coating of the back in terms of longevity.

### **3.4.2 Subsystem #2: Insulating Cover for Device**

The type of insulating clear cover for the thermal heating air unit depends on how much heat can be contained within the unit. This system is important because the material depends on how much heat can be kept within the unit and pumped into the home. In terms of longevity, if the system contains too much heat then it can melt any plastic pieces within the unit or the fan that pushes the hot air into the home.

#### **3.4.2.1 Existing Design #1: Double Walled Plastic Cover**

The doubled walled plastic cover uses UV-resistant plastics with a small pocket of air in between the two sheets of plastic. Because it is UV-resistant, the plastic can last for many years without any noticeable fading. By testing with different types of plastics, SolarThermiX decided that this type of material is best suited to work with their type of solar thermal air unit. In terms of thermal resistance, this material has a relatively high resistance and thus provides good insulation for when there is cold air outside in the winter.

#### **3.4.2.2 Existing Design #2: Triple Walled Plastic Cover**

This cover implements the same concept as the double walled plastic cover except it has yet another wall of air insulation. This at times provides excess heat during the summer and has the potential to produce

extremely hot air and can melt this plastic cover. In terms of longevity, this cover will not be able to keep the air hot for 10 years of service. For heat, this cover will perform above the maximum in terms of heat for the air, but if the cover is deformed then it will fail to retain the heat in the unit.

#### **3.4.2.3 Existing Design #3: Lexan Glazing**

Lexan is a type of clear polycarbonate sheet that is used solely to act as a weather shield for the unit. Due to its thickness, this material does not have very high thermal resistance compared to the other coverings. This material does have a 10 year guarantee against yellowing and breakage, so this handles the engineering requirement to last for 10 years. In terms of heat storage, this material will handle slightly worse than the other materials, but for the guaranteed indestructibility, this material seems to be a great choice to implement into a heating unit.

### **3.4.3 Subsystem #3: Phase Change Material**

Because there is a multitude of types of PCM, the three practical phase change materials that are used are oil and polystyrene, solid-solid, and a salt hydrate based materials. This subsystem is implemental in determining which material would tend to fare the best in the considered temperature conditions on the Navajo Nation. Because SRP required that the team implement PCM in tandem with the solar thermal air heater, the choice of phase change material will be crucial in heating the Navajo homes

#### **3.4.3.1 Existing Design #1: Oil and Polystyrene**

This phase change material takes polystyrene and mixes it with plant based oils to dissolve it. This is good in the sense of environmental helping because it reduces plastic waste. Because there are concerns for household fires, this material would not be best in order to implement because both plastic and oil are extremely flammable. This material does have good thermal heat properties and it can be relatively cheap to produce, but because of the major concern of safety of residents, this phase change material type is not the best option.

#### **3.4.3.2 Existing Design #2: Solid-Solid**

This phase change material has a range from 77 to 356 degrees Fahrenheit. This would prove slightly ineffective with this type of PCM and thus would not suit the temperature parameters of a hogan. The heat of this PCM, because it stays as solid material, is also inefficient because it does not undergo liquid to solid heat emission during the night. Due to the two subjects discussed prior, this PCM is ineffective for the location and application that it needs to be used for, this PCM should not be used in the team's design.

#### **3.4.3.3 Existing Design #3: InfiniteR Salt Hydrate**

This phase change material implements clay, water, and salt crystals so that it can melt at around 73 degrees Fahrenheit. This would be perfect for a hogan on the Navajo Nation because the solar thermal air heater can heat the air inside of the house by about 70 degrees. When it is snowing, the hot air will be sufficiently able to melt this material. Because of the natural and nonflammable ingredients in this type of PCM, there are no safety hazards for the residents. The thermal resistance for this material is very high when compared to housing insulation, so at night when the PCM freezes from liquid to solid during the night, this will provide heat for a fair amount of time. Considering all of the requirements, InfiniteR fits most of the requirements the best and thus should be used in the final design.

## 4 DESIGNS CONSIDERED

With the team's background knowledge and research, the team was able to brainstorm potential designs for the project.

### 4.1 Design #1: Vertically Heated Box with Removable PCM

In Figure 7, there is a vertically positioned box that uses a solar thermal air heater in order to heat the PCM which is stored inside of a box. The insulation is to keep the heat inside is made of Green Rhino brand Styrofoam building material which has very good thermal resistance. In order for the material to not degrade, it will be covered in special coating in order to ensure strength. During the day, the PCM will heat up and melt, and during the night, the material will be removed and put inside of the house. A pro of this design is that it contains heat easily so there will be minimized loss. A con of the design includes difficulty in having to transfer the PCM at night and in the morning.

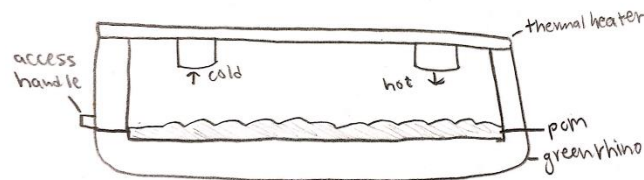

Figure 7: Vertically Heated Box with Removable PCM

### 4.2 Design #2: Wall Integrated PCM with Roof Mounted Heating Unit

In this design (Figure 8), it uses a roof mounted solar thermal air heater. Using a small solar PV panel, it will provide power to a fan to push hot air into the home during the cold winter days. During this time, excess heat will seep into the walls and melt the PCM. During the night, the PCM will release heat back into the home and provide substantial warmth. A pro of the system is that it can provide heat to the residents both during the day and the night, while it is disadvantageous that it will not provide significant heat throughout the night as well as intruding into the prior structure of the house.

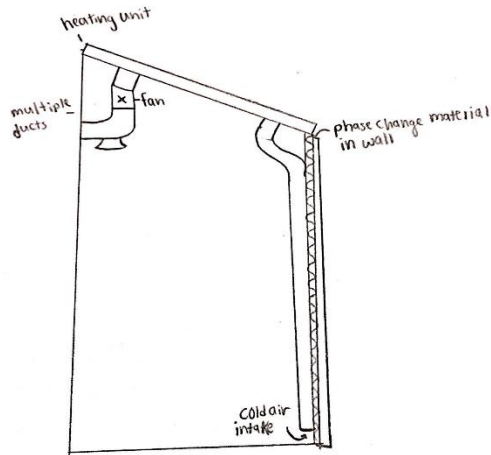

Figure 8: Wall Integrated PCM with Roof Mounted Heating Unit

### 4.3 Design #3: Door-Replacing Heat Box with Fan

This design (Figure 9) uses a rolling system in order to roll the box to and from the doorway of the home. During the day, the heater will heat the PCM, which is permanently held in the box. There is a slider that will prevent heat from escaping while the PCM heats during the day and removes when transferring heat from the box to the home. At night, the design will be rolled in front of the home's door, and a thermal exchange generator will provide the power to run a fan to circulate the hot air into the home. This design is useful for the night because it provides much heat and provides good circulation into the house, but it is not useful in the sense that it blocks the resident's door which may pose as an emergency hazard.

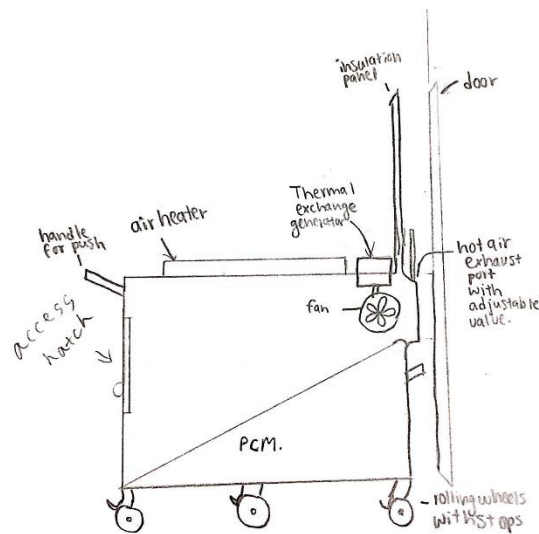

Figure 9: Door-Replacing Heat Box with Fan

#### 4.4 Design #4: Wall-Mounted Constant Heating Device

This design (Figure 10) uses a wall-mounted solar thermal air heater installed facing south to output maximum heat during the winter. After the hot air reaches the top of the panel, the solar powered fan pushes the air out into an enclosed box that stores phase change material. After the hot air passes through the PCM, the duct then emits warm air into the home. This allows constant heating because at night the resident will remove the PCM and lay it out in order to exude heat into the room, which proves to be a pro. A con of this design is installing the heating unit and mounting it onto the wall because it takes extra time and effort.

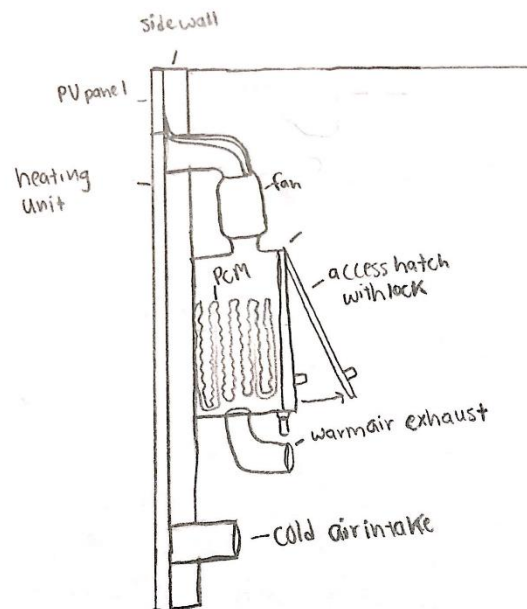

Figure 10: Wall-Mounted Constant Heating Device

#### 4.5 Design #5: Switch-Based Ducted Heating Storage

The main component of this design (Figure 11) is to use the PCM as a thermal battery during the day, and it is held inside of the home to minimize heat loss. There is a wall-mounted solar thermal air heater and a solar PV panel which powers the fan. During the day, the fan will send the hot air into the phase change material box, while temperature sensors will close off the heat when the PCM produces a desired temperature. This switch will change the direction of the heat flow from the heating unit to the PCM to the inside of the house. A pro to this concept is that there will be excellent heat emitted from the PCM bank into the house during the night, whereas a con is that there is no fan to pump heat into the house at night and there needs to be ductwork in the house if there is space.

## Air Distribution and Storage

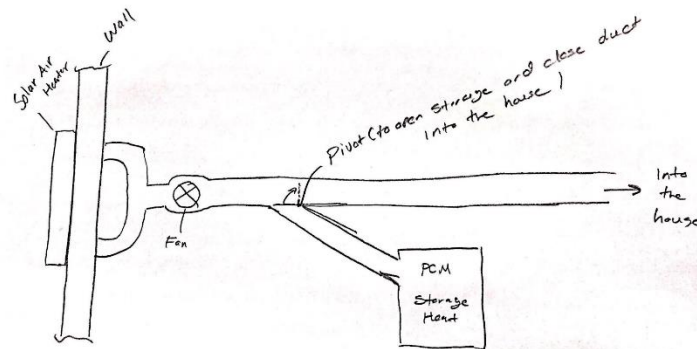

Figure 11: Switch-Based Ducted Heating Storage

### 4.6 Design #6: Separate Air Heater and Moveable Cylinder Heater with Weight-Driven Fan

This design (Figure 12) implements a home-heater on wheels that connects to the solar air heater which is also on wheels. Having the home-heater on wheels allows a user to move it wherever it can be best utilized. Having the solar air heater on wheels allows a user to move it for best access to sunlight. The home-heater has a mechanical weight powered fan that can either be set every day by user winding or an electrical powered device powered by the solar panels in the solar air heater. After set, the weight powered fan would act like a cuckoo clock; dissipating stored energy in the form of a raised weight, over time. The phase change material would be in the sidewall of the home-heater and would have a top access hatch for easy access to the PCM. The home-heater would have a hot air intake to take in hot air from the solar air heater and air vent to vent hot air from the home-heater pushed out by the fan. A pro to this design is that both the solar air heater and home-heater are easily movable for access, while a con to this design is that the weight powered fan might not have enough stored energy to last an entire night.

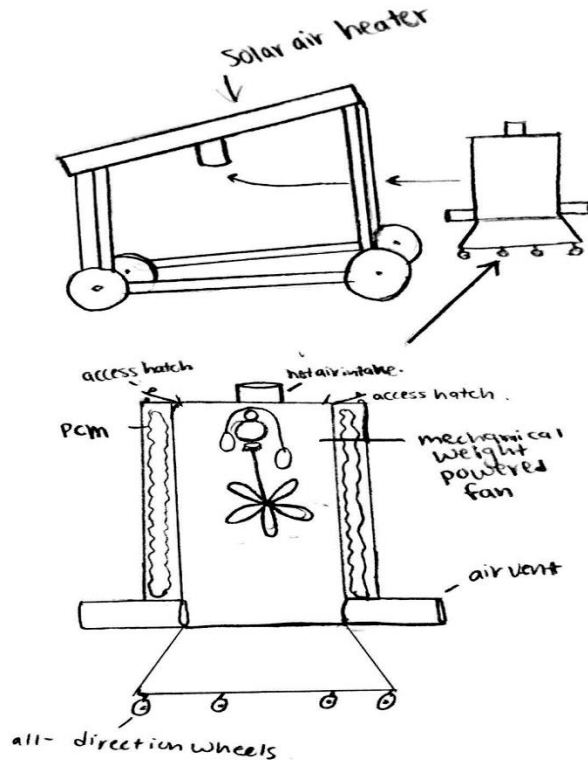
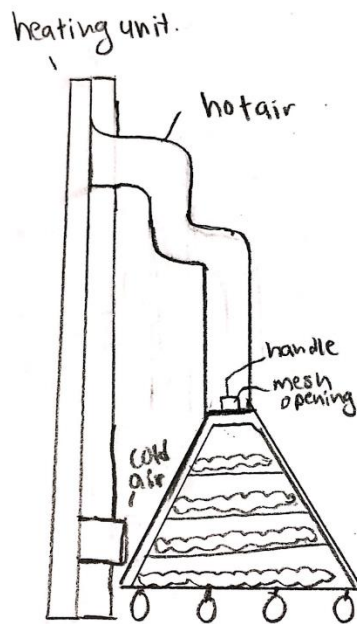

Figure 12: Separate Air Heater and Moveable Cylinder Heater with Weight-Driven Fan

#### 4.7 Design #7: Separate Wall-Mounted Air Heater with Duct-Work and Moveable Trapezoidal Heater

The main component of this design (Figure 13) is a movable home-heater that utilizes a wall mounted solar air heater. The ability for the home-heater to be able to move allows a user to place it anywhere convenient for adequate heating at night. A mesh opening allows warm air moving from the solar air heater through the duct to enter the home-heater and warm the PCM. This duct will be flexible for easy access to the PCM and to allow easy placement of the home-heater in the home. The cons to this design include possible inadequate circulation of warm air throughout the house without a fan, no control of the system for use at night and the need to drill into the home for hot and cold air ducts. The pros to this design are the easy access for the user.





*Figure 13: Separate Wall-Mounted Air Heater with Duct-Work and Moveable Trapezoidal Heater*

#### **4.8 Design #8: Roof Mounted Air Heater with Arduino Controlled Fan and Door Top Mounted Duct-Work**

This design (Figure 14) utilizes an ventilation system at the top of the door to push warm air from a basin of PCM into the house. A small fan is controlled by a Arduino which moves warm air from the PCM basin to the house through a system of ductwork. The Arduino triggers the fan either at a specific time or when the darkness of night triggers a sensor. The solar panels in the solar air heater can power a battery that will be used to power the Arduino and fan during the night. This basin can either be mounted on top of the house or to the side of the house. The pros to this design is that it does not require drilling into the house walls for placement of a duct system and the fan and Arduino is powered via a battery so the system can be controlled at night to effectively heat the home. A con to this design is that a battery must be used as one of the constraints to our project requires it to last about 10 years.

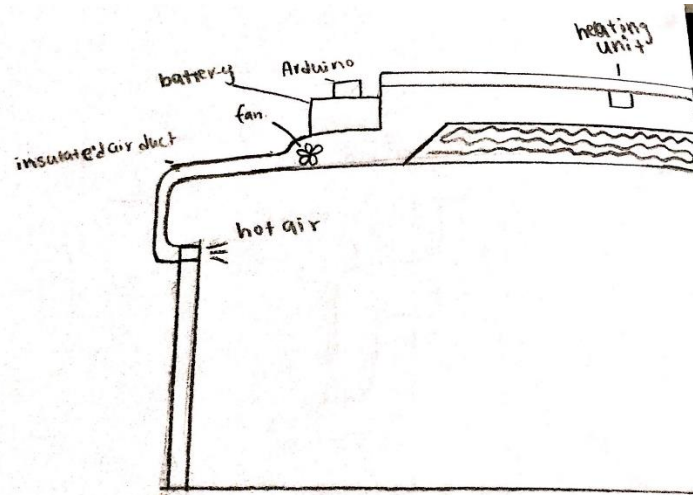

Figure 14: Roof Mounted Air Heater with Arduino Controlled Fan and Door Top Mounted Duct-Work

#### 4.9 Design #9: Beehive-like PCM Slat and Movable Solar Air Heater

This design (Figure 15) uses a solar air heater on wheels and a central box with slats of PCM as the design's main feature. The design works by pushing warm air from the solar air heater into a box with a mesh support and PCM slats. For use, the PCM slats could be pulled out and placed in the home as needed to emit warm air in the house as needed. The pros to this design is that the solar air heater is movable for placement in high sunlight and the PCM would have high access to the warm air emitted from the solar air heater. Some cons to this design are that there is no way to move the warm air from the PCM throughout the home and a user would have to move PCM slats into the home every night for use.

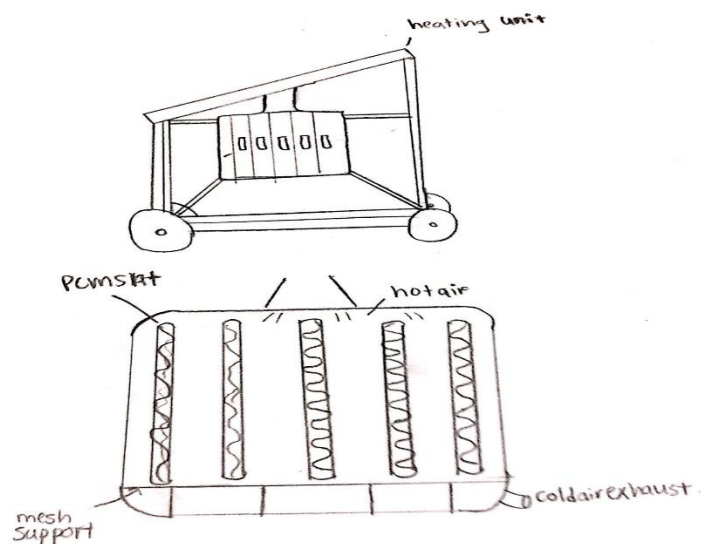

Figure 15: Beehive-like PCM Slat and Movable Solar Air Heater

#### 4.10 Design #10: Moveable Cylinder Home-Heater with Automatic System/LCD battery display and Solar Heater Station

This design (Figure 16) implements the use of a portable home-heater and solar heater. This portable home-heater utilizes a rechargeable battery to power a low-power LCD display to exhibit battery level and heat capacity, a fan to circulate heat throughout the home and a Arduino to control the systems. The solar heater station would be movable for best placement in available sunlight and would be used during the day to heat the PCM in the home-heater and the solar panel would recharge the battery. Possible cons to this device are that it requires a few components that might not last 10 years including the battery and display. Possible pros to this device are that it is easily moveable for placement in the home or in the case of the solar heater easily movable for placement in direct sunlight and it is fully automated for easy use.

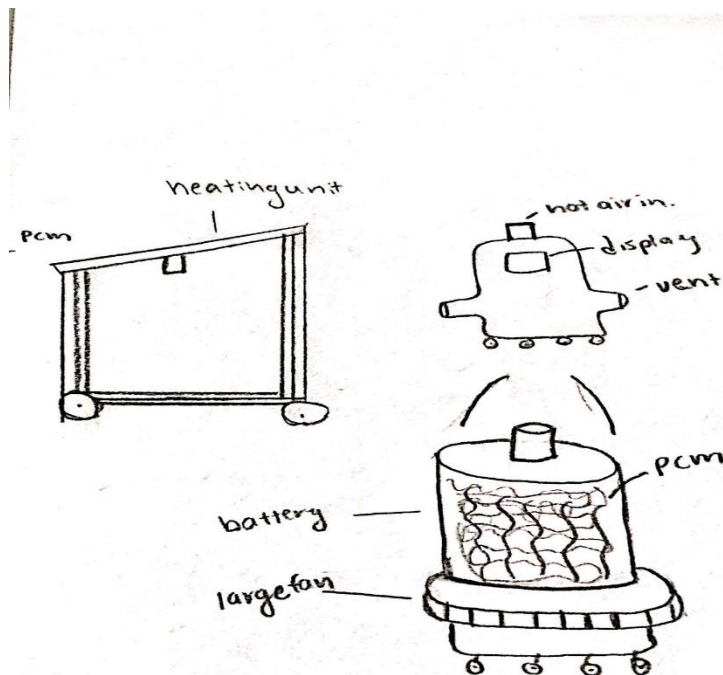

Figure 16: Moveable Cylinder Home-Heater with Automatic System/LCD battery display and Solar Heater Station

#### 4.11 Design #11: Vertically Heated Box with Heat Circulation, Control System, and Secondary Heat Source

In this design (Figure 17 and Figure 18), a vertically positioned box that uses a solar thermal air heater in order to heat the PCM stored inside of a box is utilized. The insulation to keep the heat inside is made of Green Rhino brand styrofoam building material which has very good thermal resistance. In order for the material to not degrade, it will be covered in special coating in order to ensure strength. During the day, the solar air heater will circulate heat through the home while the PCM stores excess heat. At night this PCM will dissipate heat over time and after a set period of time a coil heating system will turn on heating

both the PCM and home once again, this would cycle throughout the night. A pro of this design is that it contains heat easily so there will be minimized loss. Another pro of this design is that it will work regardless of what home/structure is needed to be heated. A con of the design includes the inclusion of so many working parts.

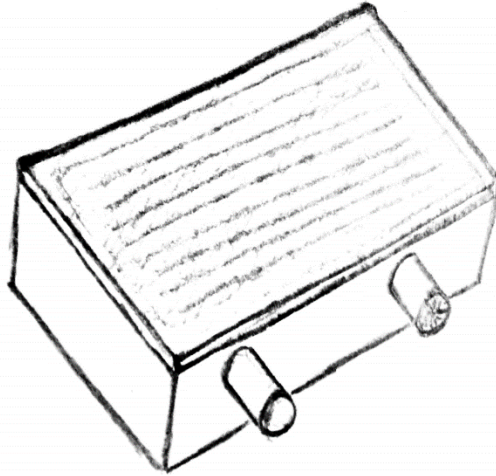

Figure 17: Vertically Heated Box with Heat Circulation, Control System and Secondary Heat Source (Outside Concept View)

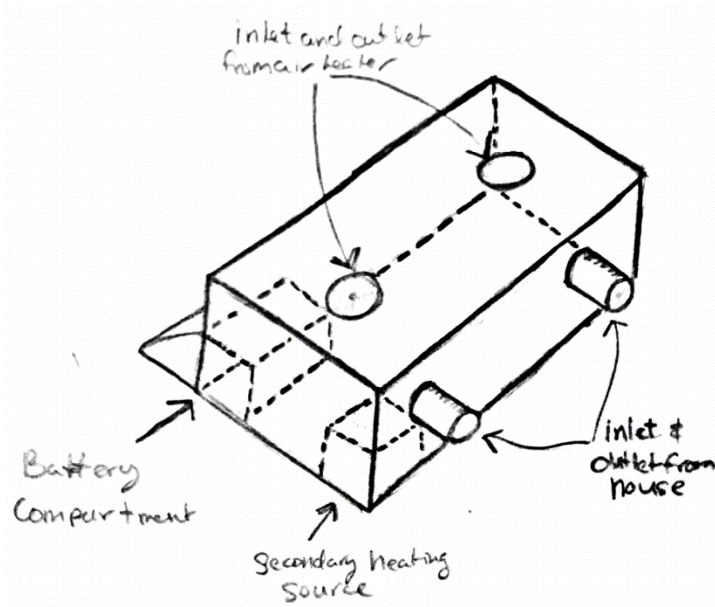

Figure 18: Vertically Heated Box with Heat Circulation, Control System and Secondary Heat Source (Inside Concept View)

## 5 DESIGN SELECTED – First Semester

Chapter 5 in *The Mechanical Design Process* contains the information of planning in the first stages of a design. By outlining, the tasks and how long the objective to get the project done on time while meeting the needs of the customer. The budget is part of the planning phase, as to how much will the materials cost for the project. The stage process is discovering the product, project planning, product definition, conceptual design, product development and supporting the product. Generating deliverables of task and a schedule that will aid in keeping the project scheduled on time. Prototyping the project is in the means of proof of function, proof of product, proof of process and the proof of production of the prototype. Using software to get the image of the product and the assembly of putting the prototype together. Also, generating a chart that will rate which prototype score the highest by rating. Also, recording the project as it progresses into the planning phase to the final phase of getting the product to the client and users. The communication with the sponsors and client of the actions that have been done in the project design.

### 5.1 Rationale for Design Selection

From the results of our Pugh Chart (Table 4), Design 11: Vertically Heated Box with Heat Circulation, Control System and Secondary Heat Source had the highest score of +16. Design 4: Wall-Mounted Constant Heating Device was very close with a score of +15. A Pugh chart works by using a list of criteria with weights to determine the best concept out of a group and is usually performed before a decision matrix to narrow down the total number of ideas. When a concept works well for one specific criteria a plus sign is recorded for that concept in the corresponding row and column, when it performs poorly with a given criteria a minus sign is recorded, and when the criteria is not affected a 0 is recorded. The weights multiply through these scores and the outcome is summed for the given concept. Design 11 performed better than all other designs on aesthetics and efficiency.

Proceeding is our Pugh Chart (Table 4) and Decision Matrix (Table 5) our choices are:

1. Vertically Heated Box with Removable PCM
2. Wall Integrated PCM with Roof Mounted Heating Unit
3. Door-Replacing Heat Box with Fan
4. Wall-Mounted Constant Heating Device
5. Switch-based Ducted Heating Storage
6. Separate Air Heater and Moveable Cylinder Heater with Weight-Driven Fan
7. Separate Wall-Mounted Air Heater with Duct-Work and Movable Trapezoidal Heater
8. Roof Mounted Air Heater with Arduino-Controlled Fan and Door-Top Mounted Duct-Work
9. Beehive-like PCM slat and Movable Solar Air Heater
10. Movable Cylinder Home-Heater with Automatic System/LCD battery display and Solar Heater Station
11. Vertically Heated Box with Heat Circulation, Control System and Secondary Heat Source

Table 4: Pugh Chart for Final Design Selection

Concept	Datum	Concept #1	Concept #2	Concept #3	Concept #4	Concept #5	Concept #6	Concept #7	Concept #8	Concept #9	Concept #10	Concept #11
Sketch	Solar ThermiX STX 7000											
Criteria/weight												
Ease of use/4	0	0	+	-	+	+	-	-	+	--	-	+
Simple design/4	0	++	-	0	+	-	-	-	-	0	0	+
Low cost/5	0	+	-	0	0	-	-	0	-	+	--	-
Size/2	0	0	0	-	+	0	0	0	+	-	+	-
Aesthetics/2	0	0	+	+	+	+	0	+	+	0	+	+++
Efficient /3	0	0	+	0	+	-	+	+	0	+	+	+++
+	0	13	9	2	15	6	3	5	8	8	7	23
-	0	0	9	7	0	12	13	8	9	10	14	7
Net Score	0	+13	0	-5	+15	-6	-10	-3	-1	-2	-7	+16

The results of our decision matrix (Table 5) coincide with the results of our Pugh chart. It is evident that Design 11: Vertically Heated Box with Heat Circulation, Control System and Secondary Heat Source is the best choice for the given criteria based on its score of 7.6. Several others were close including the Design 4: Wall-Mounted Constant Heating Device with a score of 6.68. Design 11 had a better overall score on all criteria and outweighed Design 4 in the following parameters: Heat Coverage and Size. To insure accurate results the same designs were run through a Pugh chart. This chart provided very similar results, Design 11 scored the highest with Design 4 scoring just below. With this information, the team was confident with our final design selection.

Table 5: Decision Matrix for Final Design Selection

Designs	Weight	Design 1	Design 2	Design 3	Design 4	Design 5	Design 6	Design 7	Design 8	Design 9	Design 10	Design 11
Longevity	.2	8	6	4	9	8	3	7	5	7	5	7
Size	.08	8	3	4	3	3	8	5	7	5	9	9
Usability	.1	4	5	8	8	8	4	7	7	7	9	8
Complexity	.3	7	4	3	9	4	2	5	5	6	4	7
Cost	.1	6	3	5	7	4	7	7	7	7	4	6
Heat Coverage	.22	1	1	8	2	8	6	1	2	2	9	9
Totals	1	5.56	3.66	5.08	6.68	6	4.26	4.92	4.9	5.44	6.2	7.6

## 5.2 Design Description

Our team's final design is Solar Air Heater shown in Figure 19 and in Figure 20. The team's goal is to have the Solar Air Heater function during the night, and maintain a steady flow of heat throughout the night, thanks in part to a solar panel charging a 12V battery during the day. There will be no modifications to the Solar Air Heater provided by SolarThermiX. The team will use the original full scale of the Solar Air Heater which is 8 feet by 4 feet. The Solar Air Heater on the design will be sitting on top of the thermal storage box, that will slide on top of it. The thermal air storage will be entirely manufactured out of Green Rhino foam. Since, the Green Rhino foam has low thermal conductivity which it will insulate the warm air entirely throughout the day while the PCM is absorbing and storing heat. We have also implemented a coil in our design which will heat up during the day, prolonging the storage of heat into the PCM. The final design will be running a computer simulation in EnergyPlus software to test the efficiency of our product and adjusting for peak performance. After, we will show our results and conclusion with SRP at a conference in Tempe.

### 5.2.1 Final Design Selection

After the design selection process, a CAD model of our final design was created as shown below in Figure 19 and Figure 20.

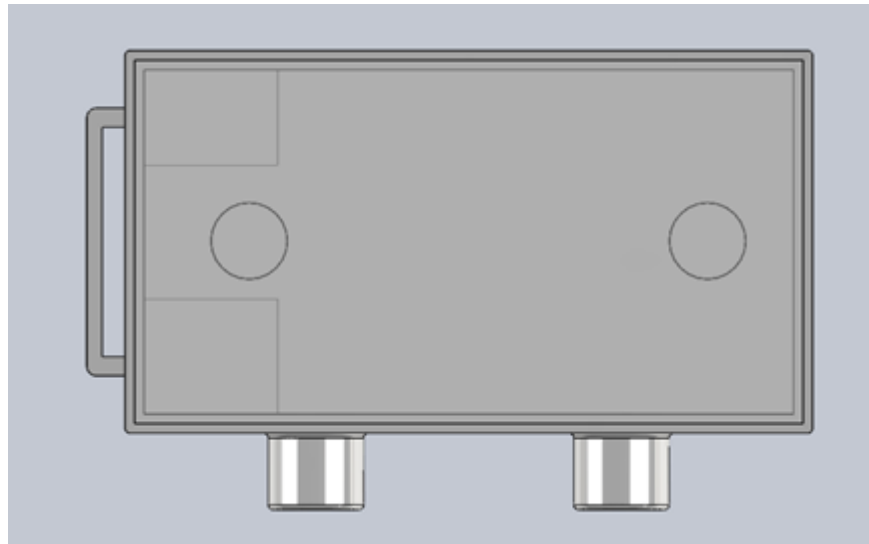

*Figure 19: Vertically Heated Box with Heat Circulation, Control System and Secondary Heat Source (Top Concept View)*

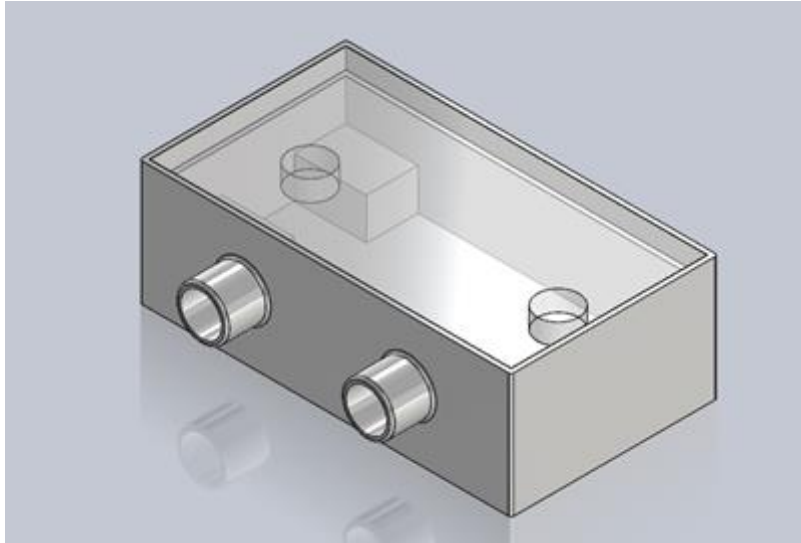

*Figure 20: Vertically Heated Box with Heat Circulation, Control System and Secondary Heat Source (Isometric Concept View)*

### **5.2.2 Dimensions of The Final Design**

The dimensions of the final design are 8 feet x 4 feet x 2 feet box that will store the heat by the PCM, shown in Figure 19 and Figure 20. The PCM will hang by a length of 1.125 feet apart sitting in the box by a length of 8 ft. This will collect the heat generated by the solar air heater which produces the heat during the day. However, the dimensions of the box will change after testing it in the box. The heat stored must last from sundown of the previous day into the next day if possible. If the heat carries on to the next day, then it will be a considered successful after 3 trials if the box needs to be scaled down.



## 6 PROPOSED DESIGN – First Semester

This section will be describing the deliverables that the team were given to complete for both the spring semester. Each one of these deliverables has tasks that were needed to complete the assignment/deliverable that was given. These tasks were split up to each team member, this was to ensure that each team member contributed to each of the assignments. The schedule will be shown as a Table 5, in chronological order from when the first assignment was due to the last assignment.

### 6.1 Implementation Plan

To implement the final design, the team will be combining two types of testing that will show the efficiency of the heater. The first type of testing will be used with the help of the computer software known as EnergyPlus. This software will test the energy consumption of the design and give the team numerical figures to compare to the conventional wood burning stove. The use of this software will be during the month of February, this will help ensure that the design being created will work as efficiently as possible before the team begins the construction process. The next type of testing the team will implement will be prototype testing. To accomplish this, the software testing must be up to the team's specifications on how we want it to run. Once the software shows the data needed the team will start the construction process of the design. Once the prototype is completed the team will run actual tests within a hogan to gather information on how the air heater works compared to the conventional wood burning stove. The actual testing of the air heater will be done during the month of March, this will help ensure that the air heater is tested under conditions that will be encountered on the Navajo Reservation. These two types of testing will be implemented in the second semester, it will help the team create data that can be used to inform the consumer the efficiency of our product.

The manufacturing of the thermal box will be provided by Green Rhino Building Systems. A SolarThermiX Solar Air Heater will also be provided. With these assembled parts, no manufacturing is needed, the team will need to code and wire the Arduino in conjunction with the battery, fan, and coil.

### 6.2 Schedule

This is second semester assignments that the team accomplished. Each assignment has tasks that were needed for the assignments. This schedule is shown in Table 5.

Table 5: Schedule of Implementation Plan for Spring 2018

Date	Deliverable	Task
1/20/18 – 2/3/18	Building of Hogan	<ul style="list-style-type: none"><li>· During this time as a team, we will form our model to 1/5 of the actual full-scale model of hogan based on 1000 square feet.</li></ul>
2/7/18	Parts Received	<ul style="list-style-type: none"><li>· Parts that were ordered will be received.</li><li>· Inventory of the parts will be made.</li></ul>
2/12/18	Start Construction of Product	<ul style="list-style-type: none"><li>· Each team member will begin construction on their part of the product.</li></ul>

<b>02/26/18</b>	<b>Individual analysis</b>	<ul style="list-style-type: none"> <li>· After finalizing the design, new analyses should be made for each component that is different from prior design considerations.</li> <li>· Each team member must complete an analysis of their component.</li> </ul>
<b>03/5/17</b>	<b>Hardware Review</b>	<ul style="list-style-type: none"> <li>· Each component of the product is evaluated.</li> <li>· A component is assigned for a team member to review.</li> </ul>
<b>3/7/18</b>	<b>Electrical Components are Implemented</b>	<ul style="list-style-type: none"> <li>· Electrical components are added to the final design.</li> <li>· Each electrical component will be connected via microprocessor.</li> <li>· Code will be created to control each component.</li> </ul>
<b>03/12/18</b>	<b>Midpoint Report/Presentation</b>	<ul style="list-style-type: none"> <li>· The design and the process of the produce should be reported and presented.</li> <li>· Each team member should produce a report of their progress for their part of the project.</li> <li>· These reports will be combined to complete a midpoint report.</li> </ul>
<b>04/9/18</b>	<b>Final Product and Testing</b>	<ul style="list-style-type: none"> <li>· The construction of the product should be completed.</li> <li>· Testing of the product will be done.</li> <li>· A professional report will be made of the testing and the results of the product.</li> </ul>
<b>04/16/18</b>	<b>Poster/Manual</b>	<ul style="list-style-type: none"> <li>· The final product should be summarized and put into poster.</li> <li>· Each team member will produce a part of the manual that corresponds to the component they created.</li> </ul>
<b>4/20/18</b>	<b>Final Presentation at SRP</b>	<ul style="list-style-type: none"> <li>· The team will travel to Tempe to present our final product to SRP.</li> </ul>
<b>04/23/18</b>	<b>UGRADS</b>	<ul style="list-style-type: none"> <li>· Each team member will have a part of the presentation to created and practice.</li> </ul>
<b>04/30/18</b>	<b>Final Report and CAD package</b>	<ul style="list-style-type: none"> <li>· Each team member will have a section they will need to complete for the final report.</li> <li>· CAD drawings will be made and finalized to be turned in with the final report.</li> </ul>

### 6.3 Budget Proposal

The budget proposal is estimated to be \$2,286 for the purchase of materials needed for the project. Table 6 is a budget, listing with the corresponding material's cost. A single PCM sheet was donated by SRP along with a SolarThermiX STX 7000 Solar Air Heater The team will need to purchase an additional 9 2feet by 4 feet sheets for a total of 10 sheets of PCM.

Table 6: Budget Proposal for NAU SRP Team

SRP Budget Proposal				
	Item	Cost	Quantity	Source
	Solar Air Heater	\$1,500	1	Donated by SolarThermix
	PCM(Phase Change Material)	\$205.20	9 (2 ft by 4 ft)	One PCM was donated by SolarThermix
	Travel	\$50		
	Stainless Steel	\$52.98	4	Home Depot
	12V Battery	\$97.89	1	Wal Mart
	Coil	\$50.00	3	
	Arduino Uno	\$40.00	1	Amazon
	Green Rhino foam	\$80.00		Donated by Solarthermix, GRBuildingsystem
	6in diameter ducting pipe	\$12.76		Home Depot
	12 V Fan	\$92	1	SolarThermix
Optional	Wood (2inx4inx10ft)	\$105.60	30	Home Depot
	Total budget	\$2,286		

## 7 REFERENCES

- [1] M. Daly. (2017, Sept.) Solar Air Heater – SolarThermiX [Online]. Available: [www.solarthermix.net/heat](http://www.solarthermix.net/heat). [Accessed: September 21, 2017].
- [2] M. Daly. (2017, Sept.) Phase Change Material – SolarThermiX [Online]. Available: <http://www.solarthermix.net/phase-change>. [Accessed: September 21, 2017].
- [3] SRP. (2017, Jan) SRP: Salt River Project Power and Water [Online]. Available: [www.srpnet.com/default.aspx](http://www.srpnet.com/default.aspx). [Accessed: September 19, 2017]
- [4] Home Power Inc. (2017, Jan.) Solar Air Heater Anatomy [Online]. Available: [www.homepower.com/sites/default/files/articles/ajax/docs/Heater\\_Anatomy.jpg](http://www.homepower.com/sites/default/files/articles/ajax/docs/Heater_Anatomy.jpg). [Accessed: September 18, 2017]
- [5] GR Building Systems LLC. (2017, Jan.) GR Building Systems [Online]. Available: <http://grbuildingsystems.com/>. [Accessed: September 18, 2017].
- [6] Insolcorp. (2015, Jan.) Infinite R™ | Phase Change Materials | Thermal Storage | Insolcorp, Inc [Online]. Available: <http://www.insolcorp.com/>. [Accessed 7 Nov. 2017].
- [7] PCM Products Ltd. (2017, Jan.) pcmproducts.net [Online] Available: <http://www.pcmproducts.net/Phase-Change-Material-Solutions.htm>. [Accessed September 21, 2017].
- [8] Stonehaven Life RSS. (2013, Jan.) Comparing Solar Air Heater Designs & Performance [Online]. Available: <http://stonehavenlife.com/comparing-solar-air-heater-designs-performance/>. [Accessed: 06-Oct-2017].
- [9] Your Solar Home. (2017, Jan.) SolarSheat 1000GS PV-DC [Online]. Available: <http://www.yoursolarhome.com/solarsheat-products/solarsheat-1000gs>. [Accessed 6 Oct. 2017].











# 8 APPENDICES

## 8.1 Appendix A: House of Quality (HoQ)

			Technical Requirements																
1	Customer Needs	Customer Weights																	
2			Ease of Use	9	9	1	9	3	3	3	3	3	3	3	3	3	3	3	
3			Simplicity of Design	9	9	3	1	1	3	3	3	3	3	3	3	3	3	3	3
4			Low Cost	9	3	9	1	9	9	9	9	9	9	9	9	9	9	9	9
5			Safety	9	9	3	9	9	9	9	9	9	9	9	9	9	9	9	9
6			Efficiency to replace current Heating	9	9	9	9	9	9	9	9	9	9	9	9	9	9	9	9
7			Manageable Size	3	9	9	9	3	3	3	3	3	3	3	3	3	3	3	3
	Aesthetically Pleasing	3	1	1	1	1	1	1	1	1	1	1	1	1	1	1	1		
	Technical Requirement Units		Cubic Feet		Dollars		Pounds		kiloJoules		Minutes		Years		Joules per Feet per Second		Dollars		
	Technical Requirement Targets		96		2000		<100		2000		20		>10		20		200		
	Absolute Technical Importance		381		255		291		309		327		255		327		327		
	Relative Technical Importance		1		5		4		3		2		5		2		2		

## 8.2 Appendix B: Pugh Chart

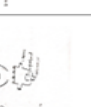
Table 3: Pugh Chart for First Semester Design

Concept	Datum	Concept #1	Concept #2	Concept #3	Concept #4	Concept #5	Concept #6	Concept #7	Concept #8	Concept #9	Concept #10	Concept #11	
Sketch	Solar Thermix STX 7000												
Criteria/ weight													
Ease of use/4	0	0	+	-	+	+	-	-	+	--	-	+	
Simple design/ 4	0	++	-	0	+	-	-	-	-	0	0	+	
Low cost/5	0	+	-	0	0	-	-	0	-	+	--	-	
Size/2	0	0	0	-	+	0	0	0	+	-	+	-	
Aesthetics/ 2	0	0	+	+	+	+	0	+	+	+	0	+	
Efficient /3	0	0	+	0	+	-	+	+	0	+	+	+++	
	+	0	13	9	2	15	6	3	5	8	8	7	23
	-	0	0	9	7	0	12	13	8	9	10	14	7
Net Score	0	+13	0	-5	+15	-6	-10	-3	-1	-2	-7	+16	