



# CAD Package

## Test Fixture for Flight Components (Willy)

Abdulaziz Alzaid – Website Developer  
Shanna Lechelt – Budget Liaison  
Israel Sotelo – Client Contact  
Alexandra Spotts – Project Manager

NORTHERN  
ARIZONA  
UNIVERSITY®



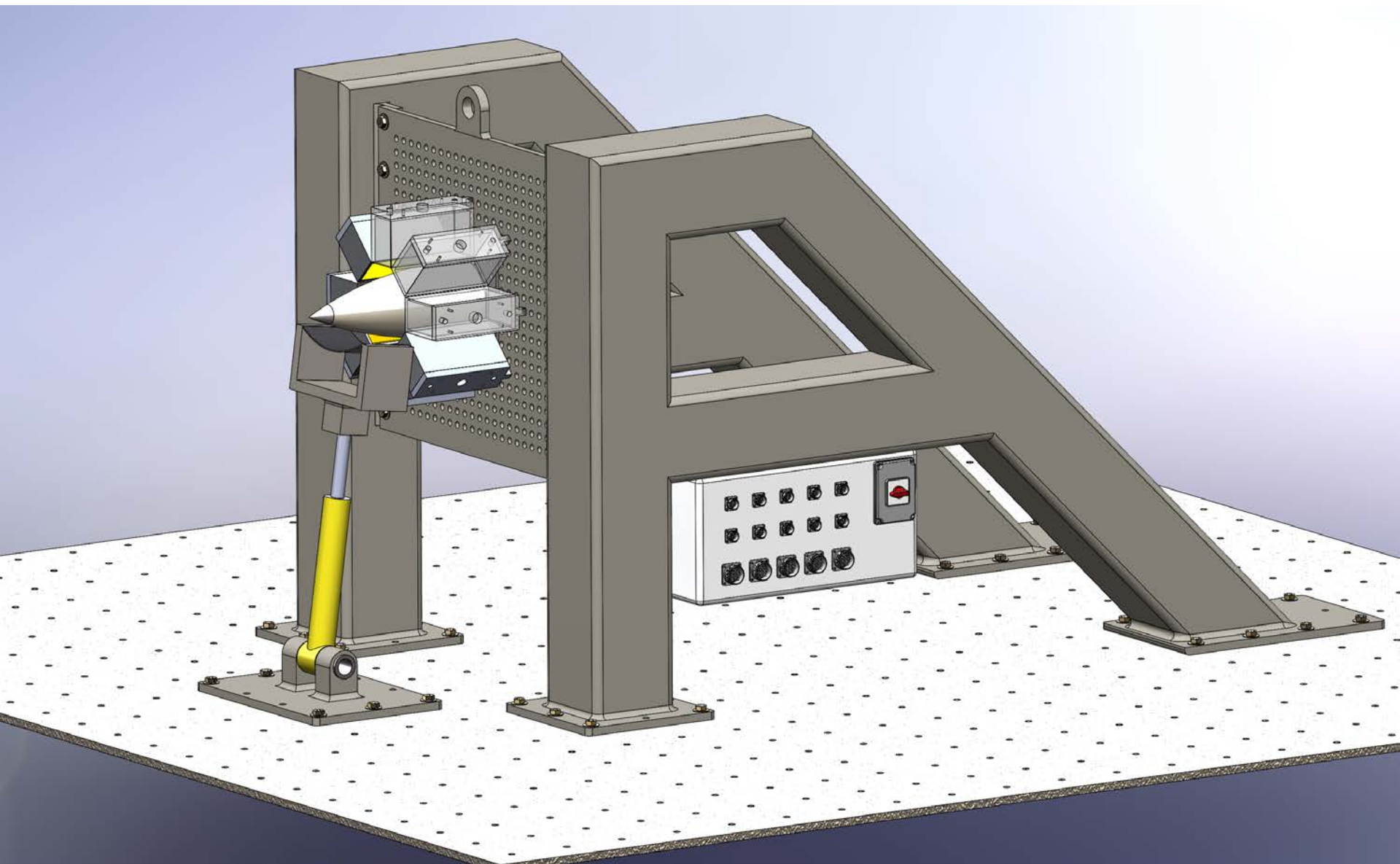

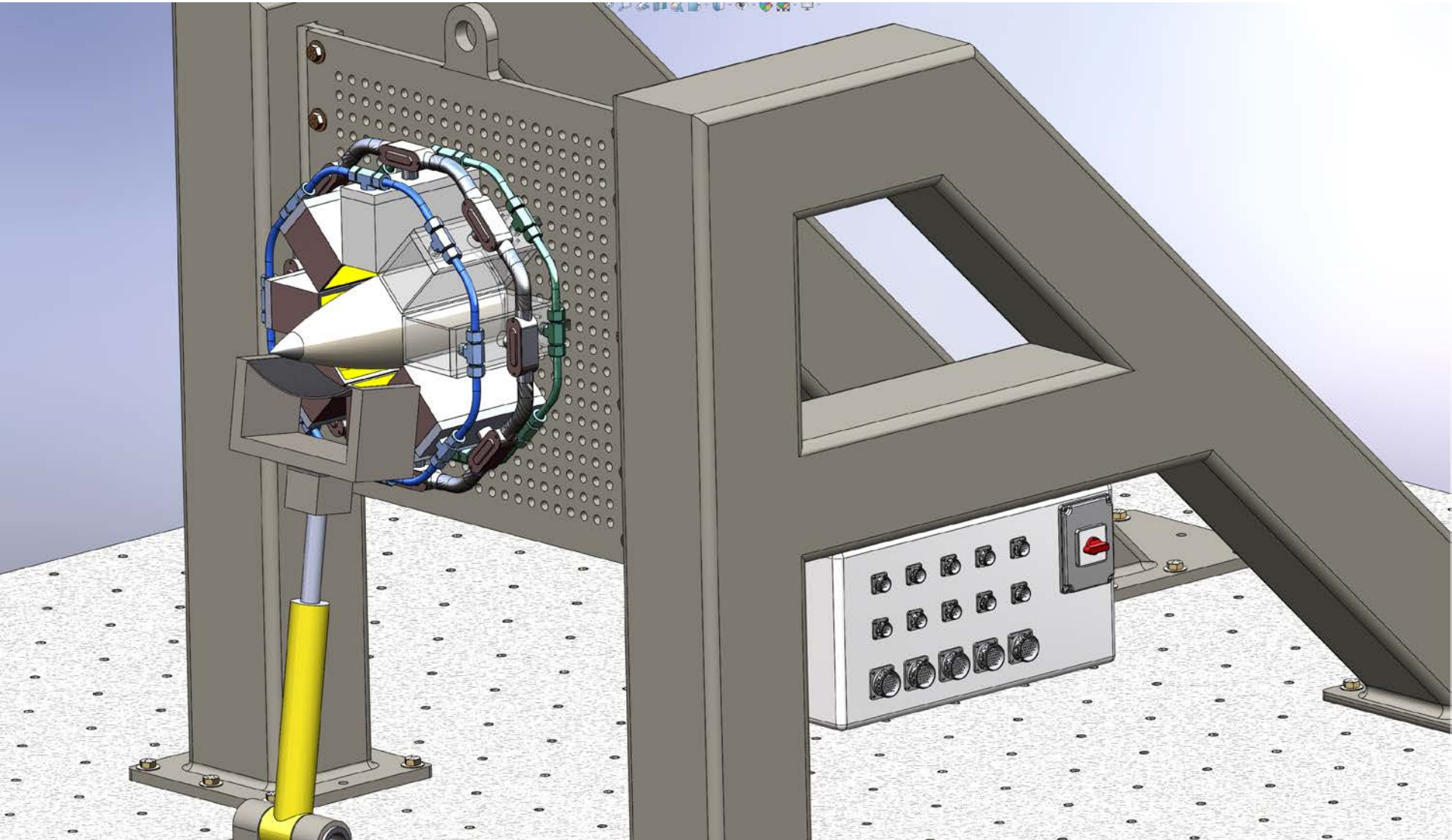

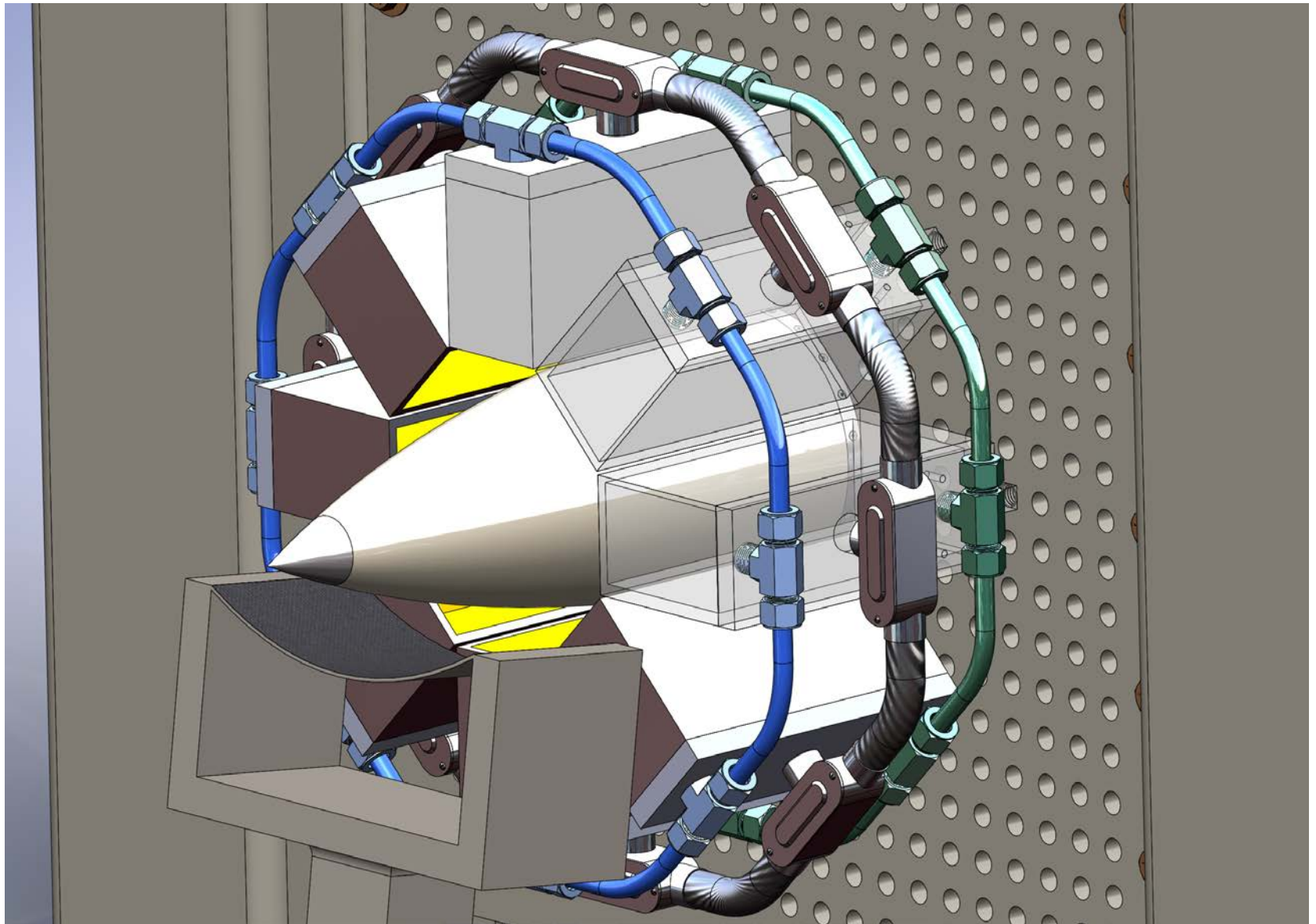



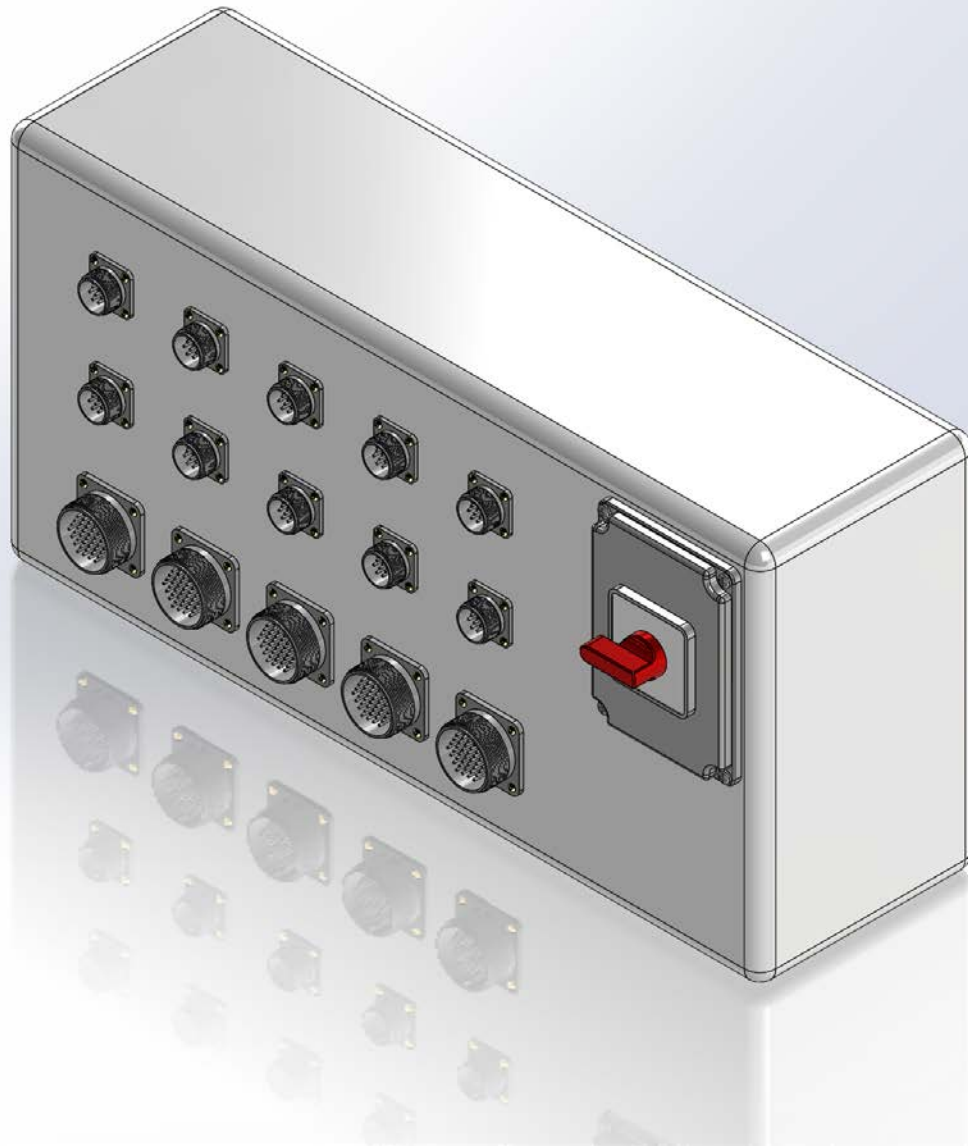

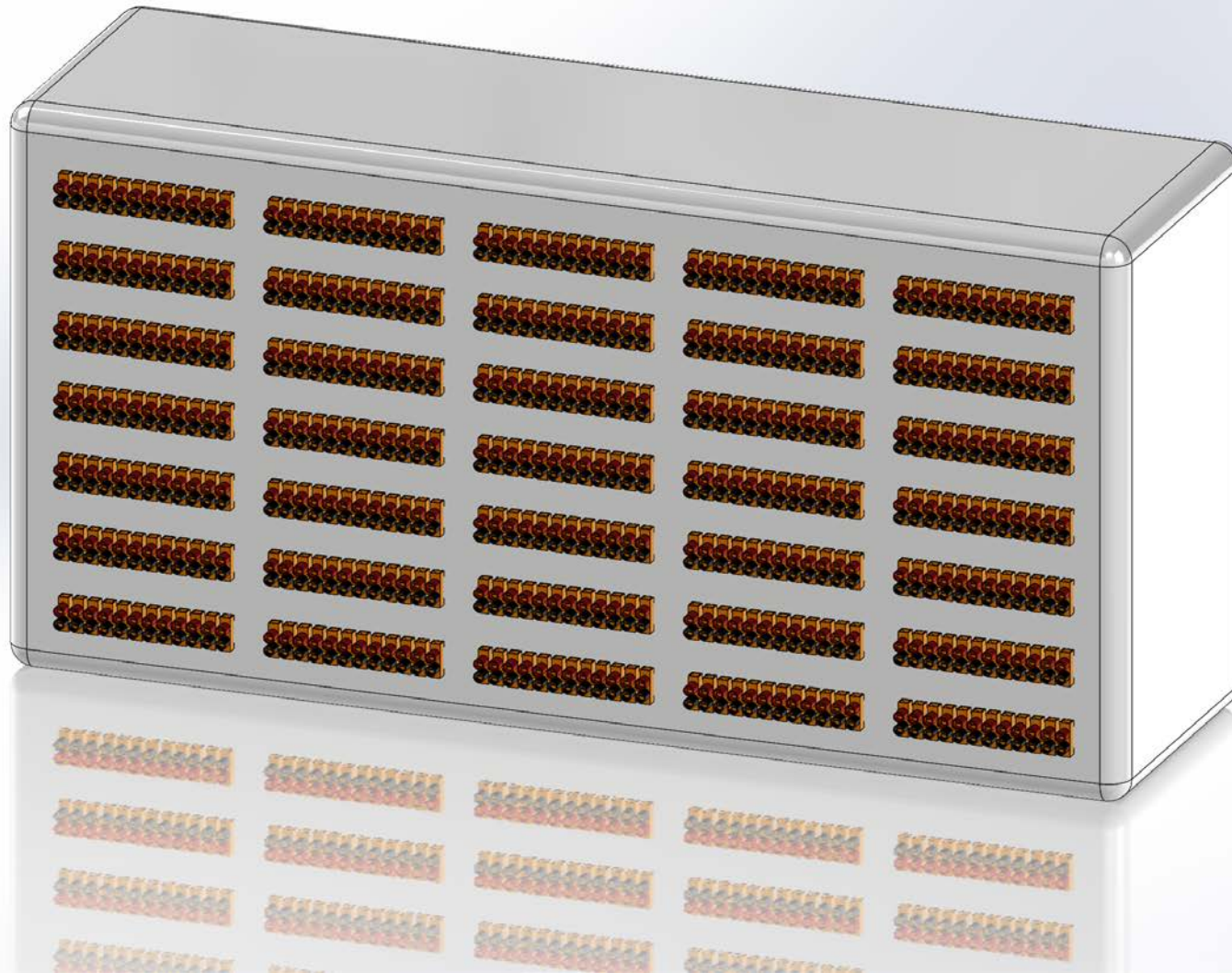

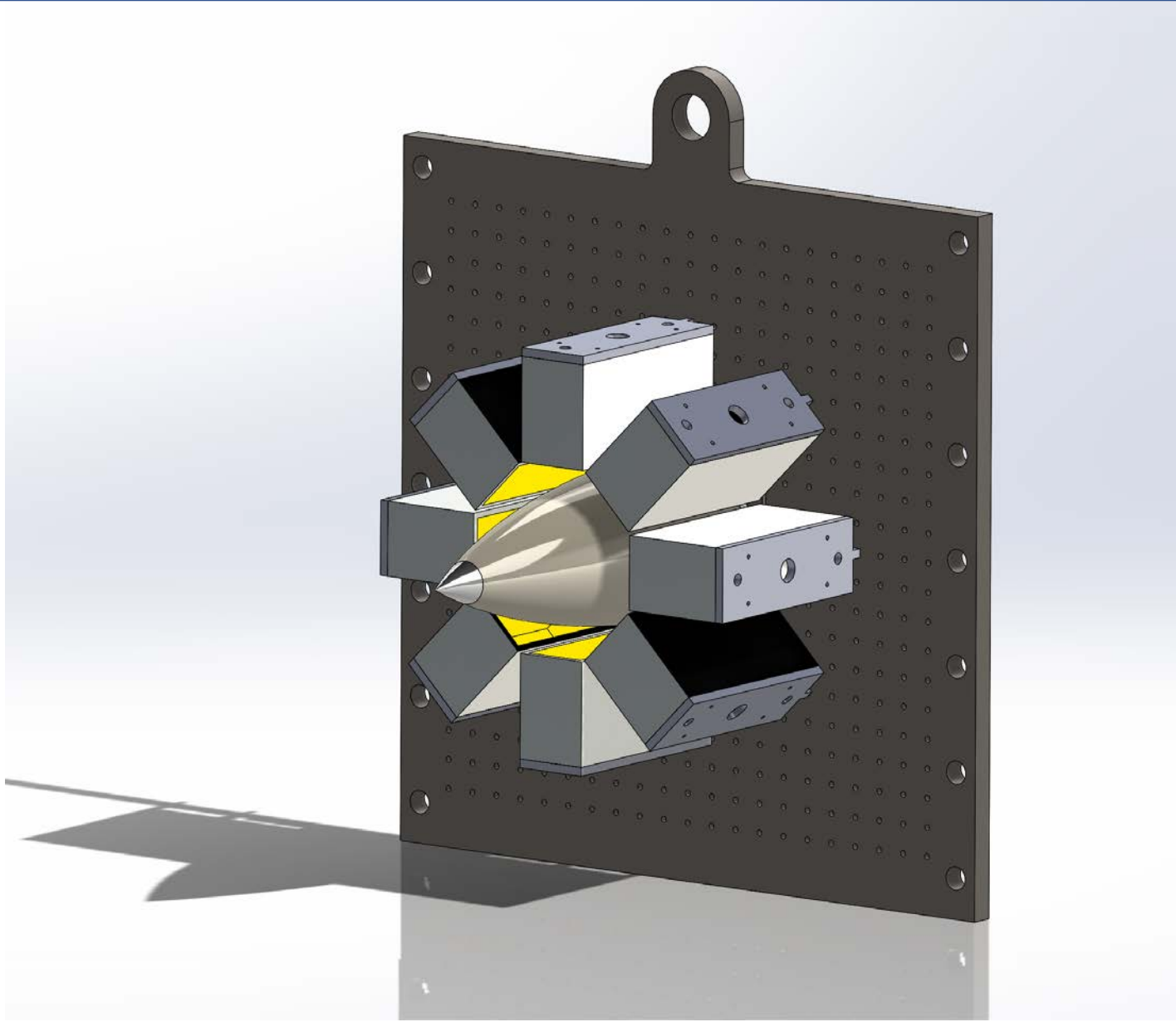





# Hi-Temp IR<sup>®</sup>

Model 5209 High Temperature Infrared Heater

## Product Data Sheet

### High Temperature Infrared Heater

The Model 5209 Hi-TempIR<sup>®</sup> heater is designed to provide high-intensity infrared heat onto localized areas.

Typical applications for this heater include:

- Stress relieving
- Metal brazing processes
- Aerodynamic heating simulation
- Thermal stress testing

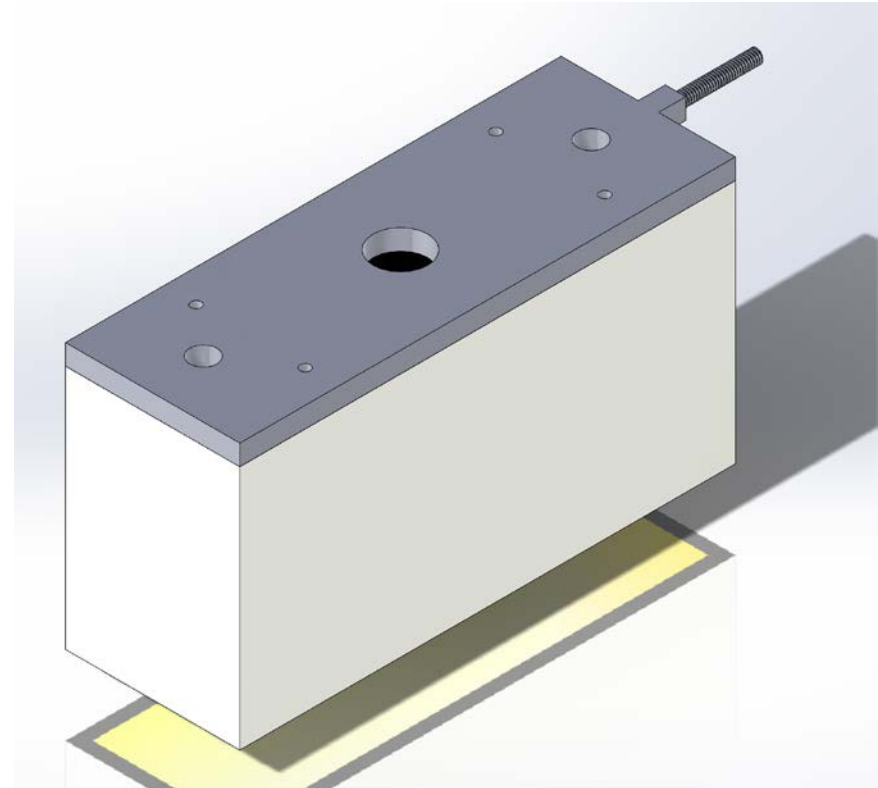

### Dimensions – Model 5209

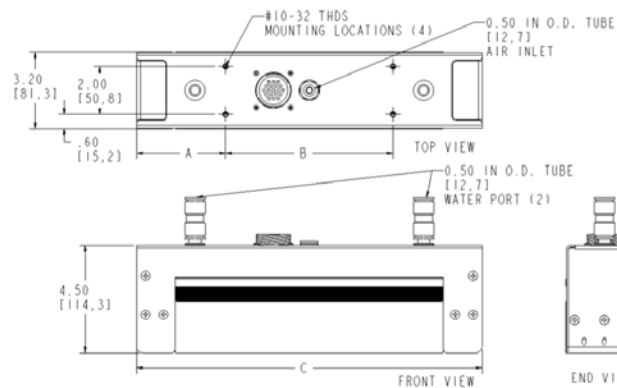

Model Number	Dimension, Inches (mm)		
	A	B	C
5209-05	1.8 (45.7)	5.5 (139.7)	9.10 (231.1)
5209-10	3.73 (94.7)	7.00 (177.8)	14.45 (367.0)
5209-16	3.73 (94.7)	12.63 (320.8)	20.08 (510.0)

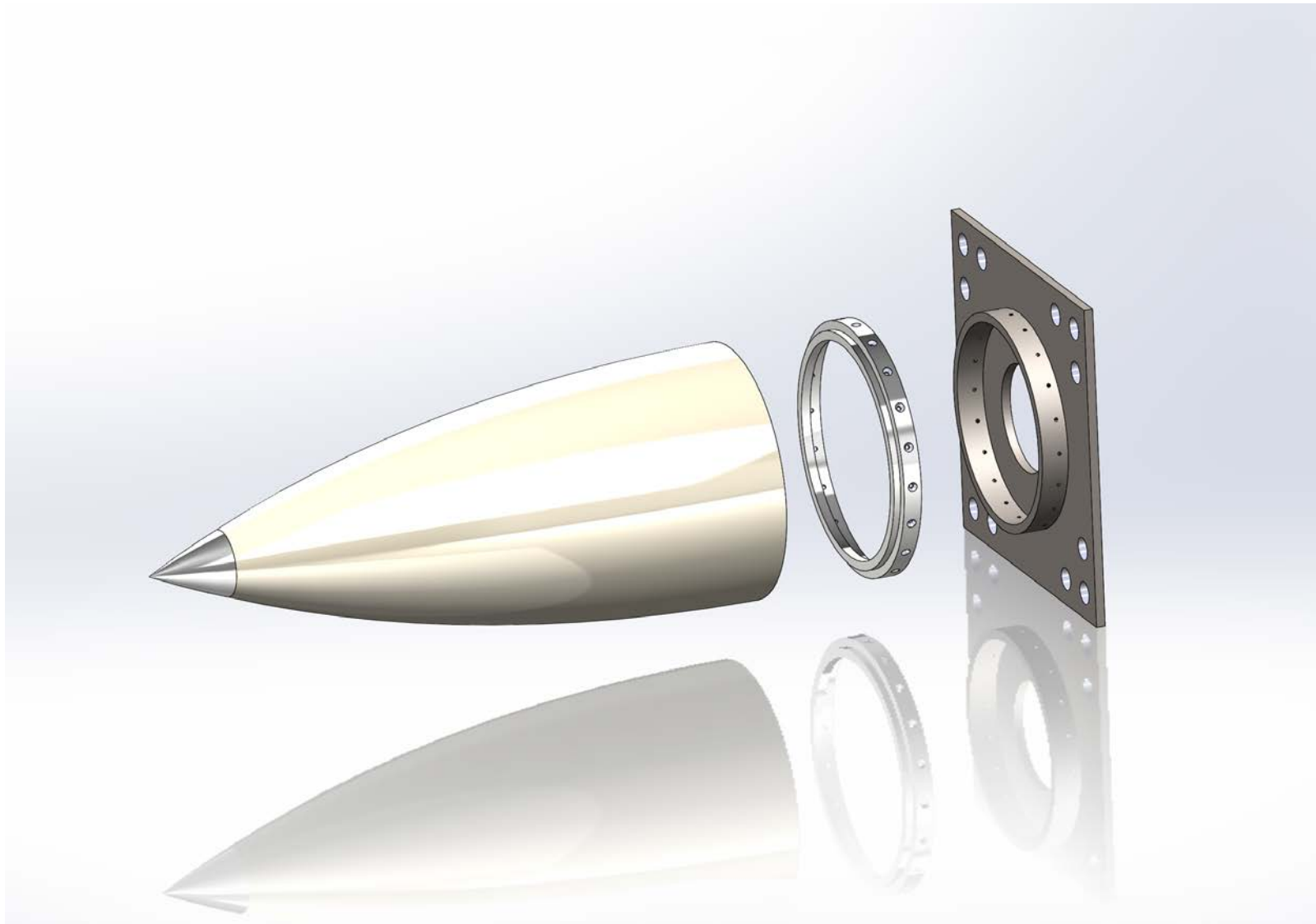

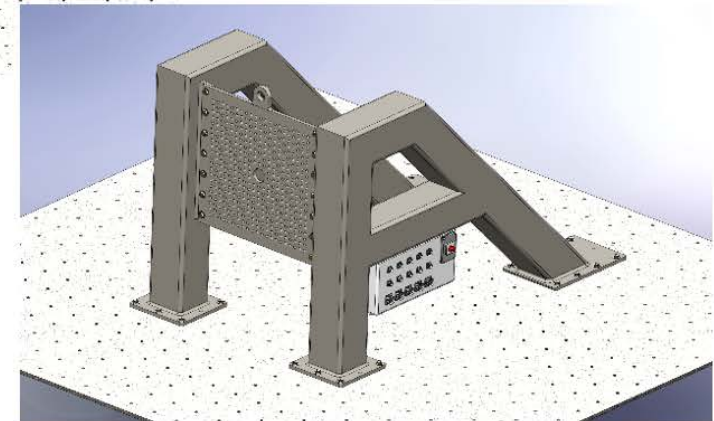
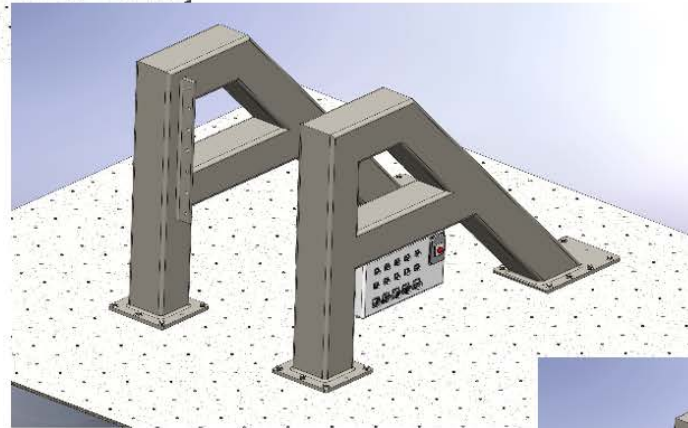
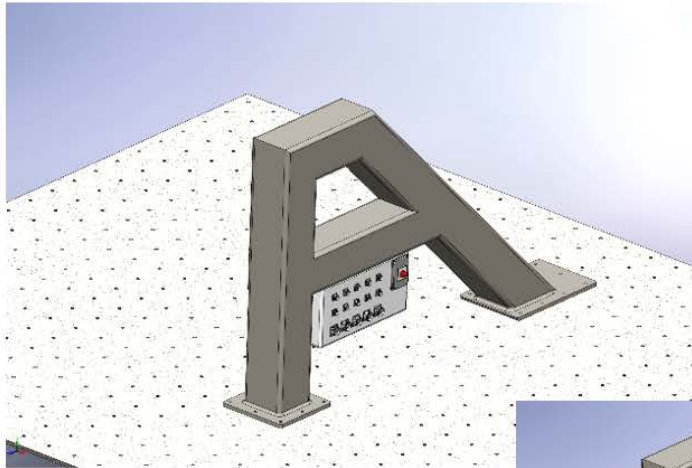

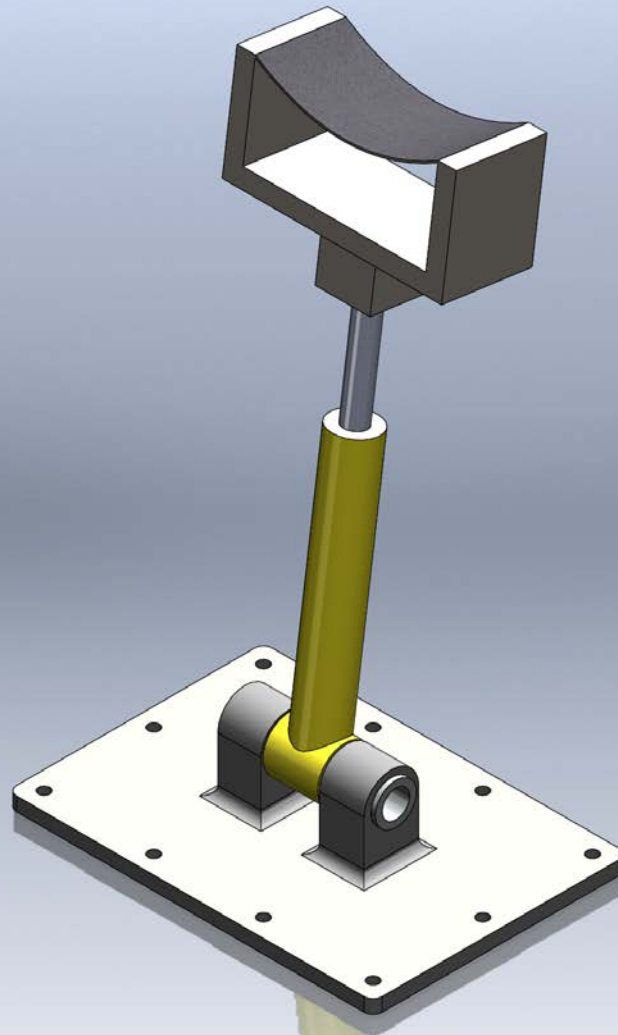

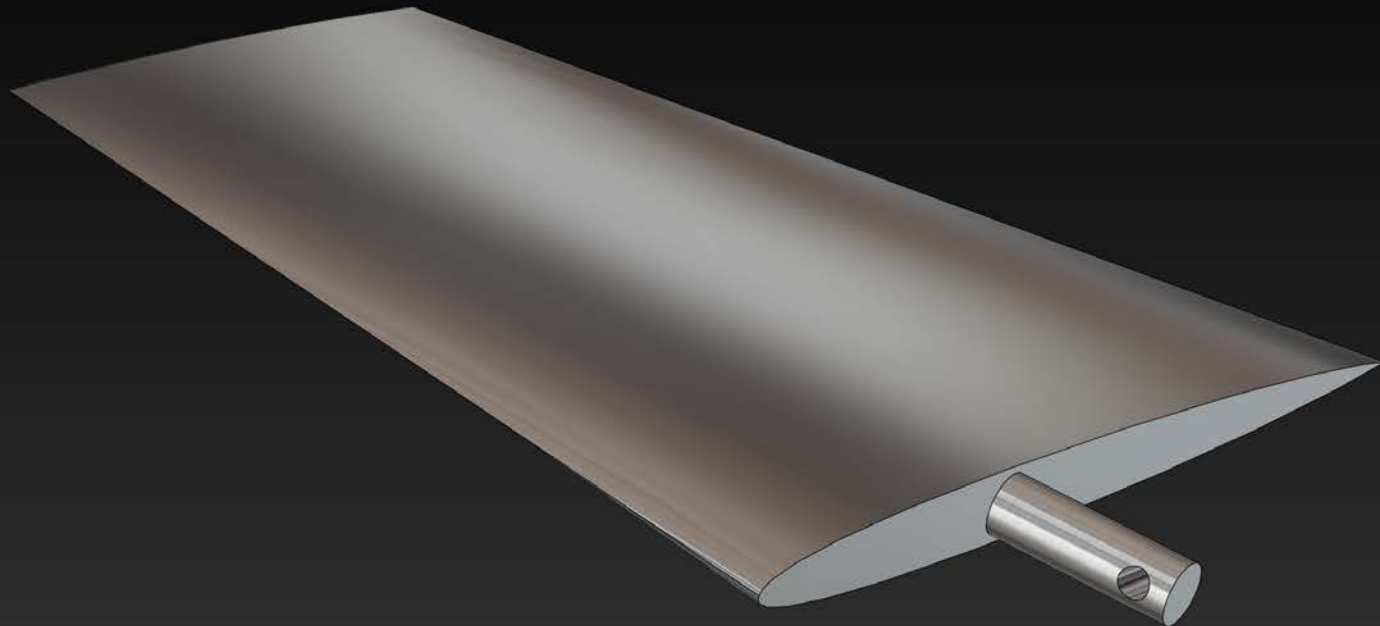

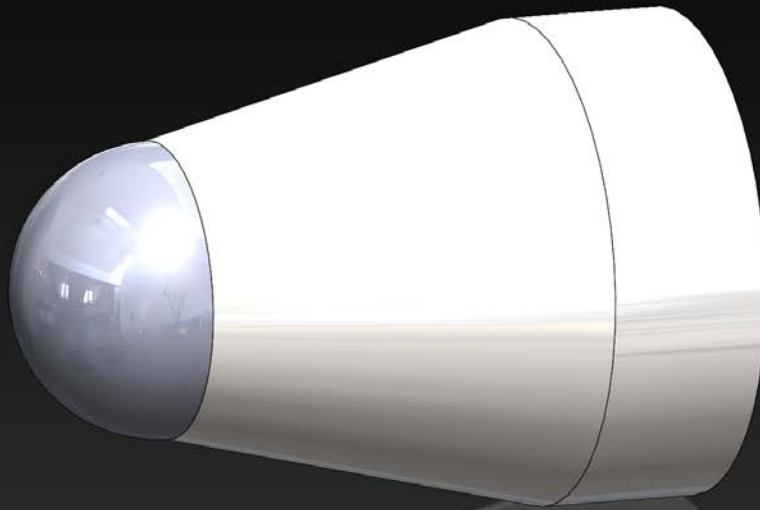



4

3

2

1

B

B

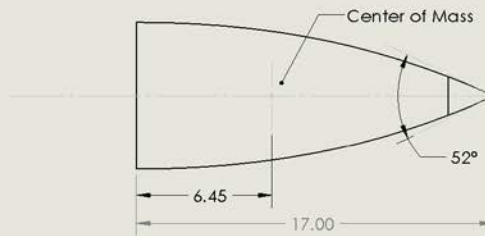
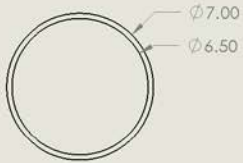

A

A

**PROPRIETARY AND CONFIDENTIAL**  
 THE INFORMATION CONTAINED IN THIS DRAWING IS THE SOLE PROPERTY OF CRISERT COMPANY NAME HERE. ANY REPRODUCTION IN PART OR AS A WHOLE WITHOUT THE WRITTEN PERMISSION OF CRISERT COMPANY NAME HERE IS PROHIBITED.

		UNLESS OTHERWISE SPECIFIED:	NAME	DATE
		DIMENSIONS ARE IN INCHES	DRAWN	
		TOLERANCES:	CHECKED	
		FRACTIONAL ±	ENG APPR.	
		ANGULAR: MA CH ± BEND ±	MFG APPR.	
		TWO PLACE DECIMAL ±	Q.A.	
		THREE PLACE DECIMAL ±	COMMENTS:	
		INTERPRET GEOMETRIC TOLERANCING PER MATERIAL		
NEXT ASSY	USED ON	FINISH		
APPLICATION		DO NOT SCALE DRAWING		

TITLE: AMRAAM Radome		
SIZE	DWG. NO.	REV
<b>B</b>		
SCALE: 1:5	WEIGHT:	SHEET 1 OF 1

4

3

2

1

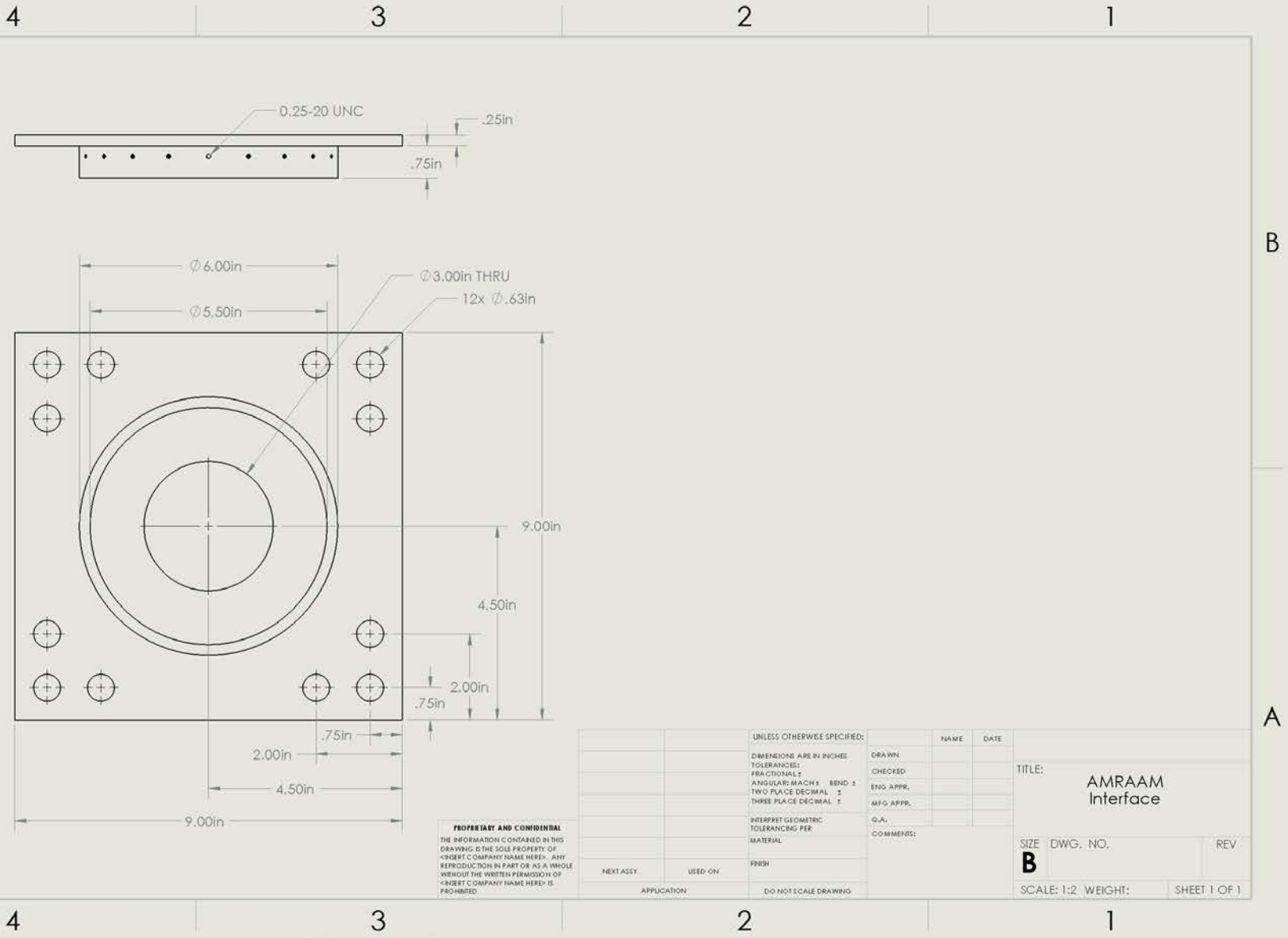

**PROPRIETARY AND CONFIDENTIAL**  
 THE INFORMATION CONTAINED IN THIS DRAWING IS THE SOLE PROPERTY OF <INSERT COMPANY NAME HERE>. ANY REPRODUCTION IN PART OR AS A WHOLE WITHOUT THE WRITTEN PERMISSION OF <INSERT COMPANY NAME HERE> IS PROHIBITED.

		UNLESS OTHERWISE SPECIFIED:		NAME	DATE
		DIMENSIONS ARE IN INCHES		DRAWN	
		TOLERANCES:		CHECKED	
		FRACTIONALS		ENG APPR.	
		ANGULARS: MACH 5 BEND 1		MFG APPR.	
		TWO PLACE DECIMAL ±		Q.A.	
		THREE PLACE DECIMAL ±		COMMENTS:	
		INTERPRET GEOMETRIC TOLERANCING PER MATERIAL.			
		FINISH			
NEXT ASSY.	USED ON				
APPLICATION	DO NOT SCALE DRAWING				
TITLE:				AMRAAM Interface	
SIZE				DWG. NO.	
<b>B</b>					
SCALE: 1:2				WEIGHT:	
				SHEET 1 OF 1	

B

B

A

A

4

3

2

1

4

3

2

1





4

3

2

1

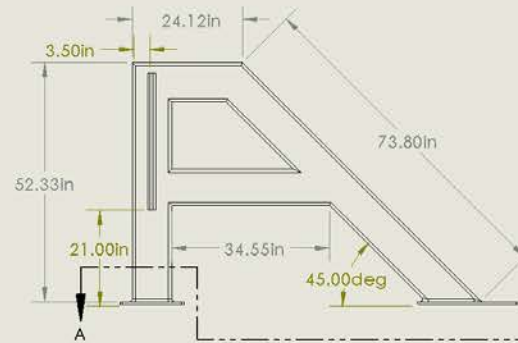
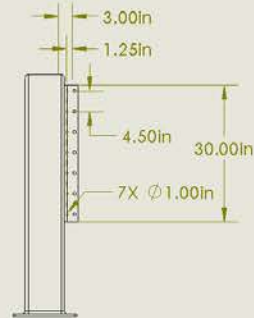
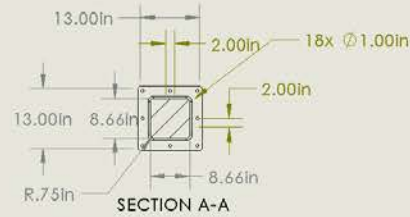
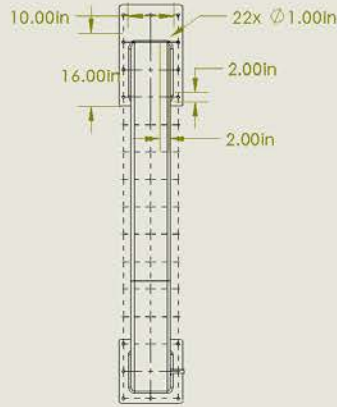

B

B

A

A

**PROPRIETARY AND CONFIDENTIAL**  
THE INFORMATION CONTAINED IN THIS DRAWING IS THE SOLE PROPERTY OF <INSERT COMPANY NAME HERE>. ANY REPRODUCTION IN PART OR AS A WHOLE WITHOUT THE WRITTEN PERMISSION OF <INSERT COMPANY NAME HERE> IS PROHIBITED.

UNLESS OTHERWISE SPECIFIED:		NAME	DATE
DIMENSIONS ARE IN INCHES	DRAWN		
TOLERANCES	CHECKED		
FRACTIONAL 1	ENG APPR		
ANGULAR: MACH ± BEND ±	MFG APPR		
TWO PLACE DECIMAL ±	Q.A.		
THREE PLACE DECIMAL ±	COMMENTS		
INTERPRET GEOMETRIC TOLERANCING PER MATERIAL			
FINISH			
APPLICATION	DO NOT SCALE DRAWING		

SIZE	DWG. NO.	REV
B	Upright Left	
SCALE: 1:24 WEIGHT:		SHEET 1 OF 1

4

3

2

1

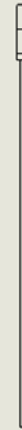
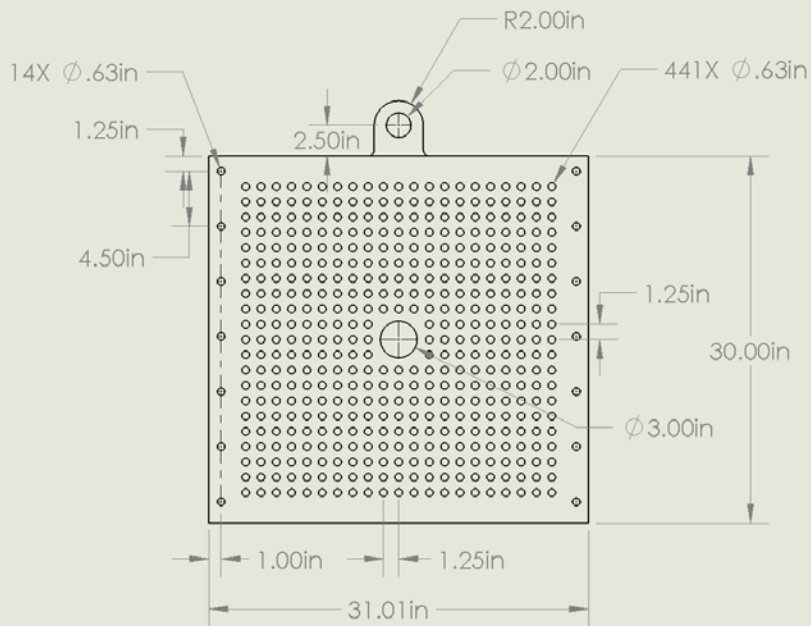

		UNLESS OTHERWISE SPECIFIED:	
		DIMENSIONS ARE IN INCHES	DRAWN
		TOLERANCES:	CHECKED
		FRACTIONAL ±	ENG APPR.
		ANGULAR: MACH ± BEND ±	MFG APPR.
		TWO PLACE DECIMAL ±	
		THREE PLACE DECIMAL ±	
		INTERPRET GEOMETRIC	Q.A.
		TOLERANCING PER:	COMMENT
		MATERIAL	
		FINISH	
NEXT ASSY	USED ON		

**PROPRIETARY AND CONFIDENTIAL**  
 THE INFORMATION CONTAINED IN THIS  
 DRAWING IS THE SOLE PROPERTY OF  
 <INSERT COMPANY NAME HERE>. ANY  
 REPRODUCTION IN PART OR AS A WHOLE  
 WITHOUT THE WRITTEN PERMISSION OF

