

# Stirling Refrigerator

## Preliminary Report

**Luis Gardetto**

**Ahmad Althomali**

**Abdulrahman Alazemi**

**Faiez Alazmi**

**John Wiley**



**2017-2018**

**Project Sponsor: Dr. David Trevas**

**Faculty Advisor: Mr. David Willie**

**Instructor: Dr. David Trevas**

## **DISCLAIMER**

This report was prepared by students as part of a university course requirement. While considerable effort has been put into the project, it is not the work of licensed engineers and has not undergone the extensive verification that is common in the profession. The information, data, conclusions, and content of this report should not be relied on or utilized without thorough, independent testing and verification. University faculty members may have been associated with this project as advisors, sponsors, or course instructors, but as such they are not responsible for the accuracy of results or conclusions.

# TABLE OF CONTENTS

## Contents

DISCLAIMER .....	1
TABLE OF CONTENTS.....	2
1 BACKGROUND.....	1
1.1 Introduction.....	1
1.2 Project Description .....	1
2 REQUIREMENTS .....	2
2.1 Customer Requirements (CRs).....	2
2.2 Engineering Requirements (ERs).....	3
2.3 House of Quality (HoQ).....	5
3 EXISTING DESIGNS .....	6
3.1 Design Research .....	6
3.2 System Level.....	6
3.2.1 Existing Design #1: Alpha .....	6
3.2.2 Existing Design #2: Beta .....	8
3.2.3 Existing Design #3: Gamma .....	9
3.2.4 Existing Design #4: Free Piston .....	10
3.3 Functional Decomposition .....	12
3.3.1 Black Box Model .....	12
3.3.2 Functional Model .....	12
3.4 Subsystem Level.....	13
3.4.1 Subsystem #1: Displacer.....	13
3.4.2 Subsystem #2: Piston.....	13
3.4.3 Subsystem #3: Flywheel .....	14
3.4.4 Subsystem #4: Gaskets & Seals .....	14
3.4.5 Subsystem #5: Fin Types .....	16
3.4.6 Subsystem #5: Linear/Rotary Motor .....	17
3.4.7 Subsystem #6: Regenerator Material.....	18
4 DESIGNS CONSIDERED .....	22
4.1 Design #1: Benchtop Apparatus .....	22
4.2 Design #2: Solar powered Ice-Chest .....	23
4.3 Design #3: Dual Piston Cryocooler .....	24
4.4 Design #4: Inline regenerative cryocooler .....	24
5 DESIGN SELECTED – First Semester.....	25
5.1 Rationale for Design Selection.....	25
6 APPENDICES.....	27
6.1 Design #5: Top Line Cryocooler .....	28
6.2 Design #6: Hut form cryocooler.....	29
6.3 Design #7: Alpha-shaped cryocooler .....	29
6.4 Design #8: Active cryocooler .....	30
6.5 Design #9: Double Regenerated Cooler.....	30
6.6 Design #10: Water Cooled Compressor Cooler.....	31

# **1 BACKGROUND**

## ***1.1 Introduction***

Experimental test equipment plays a crucial role in the curriculum of ME 495 Experimental Methods Lab. Design of a Stirling Cooling apparatus that would serve as a demonstration model has been requested by our client, Dr. David Trevas. As one of the contributing Professors to the senior level ME495 Laboratory, Dr. Trevas is interested in the creation of an experiment that requires future students to investigate the thermodynamic cycle that is utilized by Stirling technology. Importance has been placed in a benchtop scale Stirling cooler model that has variable inputs of energy sources, working gas types, temperature output.

Stakeholders would include future mechanical engineering students, the mechanical engineering faculty of Northern Arizona University (NAU), and similar laboratory-based courses in thermodynamics and fluid-dynamics at other universities. Design of experiments, as required by the course, includes a general property or process related to the measurement of fluids and temperature. Techniques involving the collection of data, methods of quantifying data, and replication of industrial applications as they relate to the Stirling cycle can be incorporated in this project. Benefits

Contemporary issues that inspire investigations into alternative methods of refrigeration that safely and effectively achieve customer requirements is the primary intention of this project. Stirling cryocoolers are widely used in many industries and offer efficient cooling solutions without potentially hazardous refrigerants or large electrical consumption. The following sections describe the project, list customer and engineering requirements, mention existing designs, suggest possible new designs, and finally lists design selection for construction.

## ***1.2 Project Description***

Discussions with the client that describe the project intentions, purpose, scope, and importance have been conducted in person as well as consultations with our experienced mentor, Professor David Willie. In the initial interview with our client, Dr. Trevas stated:

“I want something that can fit on a bench that actually cools down a six-pack of sodas from room temperature to a refreshing chill. It should be designed to be used in the ME 495 Lab as one of the experiments required for the course.”

Details and reference sources were discussed with our client during the rest of the interview along with personal experience testing and experimenting with Stirling technology. Possible configurations were suggested by our client that include the use of the free piston type due to experience with that system.

The model must be constructed from durable material that provides stable structural support for the motor/piston/displacer assembly along with a mounting surface for digital display monitors. An insulated cooling vessel will house the test medium along with imbedded thermocouples that monitor interior temperature.

## 2 REQUIREMENTS

The client has requested the design and construction of a Stirling engine or cooler that can be used to demonstrate the thermodynamic characteristics of the Stirling cycle. This device will be designed to conduct experiments that relate to subjects taught in the Experimental Methods lab (ME 495) offered at Northern Arizona University Mechanical Engineering department. The following sections describe customer and engineering requirements that have been determined from background research and interviews with our client, Dr. David Trevas, and this teams' academic mentor, Professor David Willie.

### *2.1 Customer Requirements (CRs)*

For the customer requirements (CRs), we came up with customer needs that will be prioritized in the design and construction of a Stirling refrigerator. The customer needs are transferring heat from a cooler, fits in educational lab space, externally powered, educational, safety, cost, durability, and manufacturability of the design. The customer weights were rated from a scale of 1-5, where five is the most important and one is the least important.

The overall project objective is to have a Stirling/Cryocooler engine designed safe for students to learn more about thermodynamic cycles and how they function in real life. Another objective is to create an affordable and durable design to please our client and to allow multiple generations of engineering students to be exposed to our physical model. In the House of Quality (Section 2.3) the customer need weights and how they are related to the engineering requirements (ERs) are provided.

## 2.2 Engineering Requirements (ERs)

The engineering requirements were determined by deriving measurable characteristics from the customer requirements. The table below shows the engineering requirements along with their targets. For more detailed information (units) regarding the engineering requirements, refer to the House of Quality in Figure 1.

*Table 1 Targets for ER's*

Engineering Requirement	Target Value
Fluid Viscosity	1.9
Power Input	2
Fin Effectiveness	3
Regenerator Porosity	50
Regenerator Specific Heat	.6
Regenerator Density	8
Compression/Expansion Space	.2
Flammability	1
Condensation Temperature	4
Insulation effectiveness/Conductivity	10
Number of Seals	2
Seal Hardness	7
Friction from Seal	.05
Compressibility Factor	.95
Frequency	70
Phase Angle	90
Dead Volume Fraction	.25
Cooling Space Volume	.009
System Volume	.17

The targets for the ER's will now be explained. Namely, the fluid viscosity was based on the viscosity of Helium. The power input was based on the average power supplied by a wall outlet. The fin effectiveness was estimated using the textbook "Fundamentals of Heat and Mass Transfer". The regenerator porosity, specific heat, and density were based off values found in the literature for various materials, while specific attention was given to stainless steel properties because of its presence as a common regenerator material. The compression/expansion space was estimated with a back of the envelope calculation with an estimate for how large the overall system is. The flammability was specified with reference to the baker hazard code. The

condensation temperature was based on Helium. The conductivity of the insulation was based on values found in the literature for different insulators. The number of seals was determined based on the different configurations for a Stirling refrigerator, while hardness was based on the literature. The friction from the seal and compressibility factor of the fluid was based on a working knowledge of mechanics and thermodynamics. The frequency was based on the various values found in the literature, while the phase angle was determined based off the background from the different configurations of the refrigerator.

Finally, the different volume targets were found with back of the envelope calculations, while estimating the overall volume based on context given by Dr. Trevas, namely, the fact that it will fit in a lab space. The dead volume fraction was also estimated based off various values found in the literature, while keeping in mind that this was an important parameter, with respect to power input.

### 2.3 House of Quality (HoQ)

Customer Needs	Customer Weights																			
	Decrease Fluid Viscosity	Power Input	Hot Cylinder Fin Effectiveness	Increase Regenerator Material Porosity	Increase Regenerator Material Specific Heat (C <sub>v</sub> )	Increase Regenerator Material Density	Increase Compression/Expansion Space	Decrease Working Fluid's Flammability	Decrease Condensation Temperature	Decrease Cooling Space's and Regenerator's Wall Conductivity	Decrease Number of Seals	Increase Piston Seal Material Hardness	Decrease Piston Seal Coefficient of Friction	Increase Compressibility Factor	Frequency	Phase Angle*	Dead Volume Fraction	Cooling Space Volume	System Volume	
Transfer Heat from cooler	5	7	9	9	5	8	8	9		4	7	7	5	8	8	9	5	9		
Fits in Lab space	4			5				9			6	4		5			8	7	9	
Externally Powered	3	6	9	3		3	2	7					3	4	3	2	9	7	7	
Educational	3	2	4	5	1	1	1	3	1	1			4	1	1	1				
Safety	5	4	5	5	3	3	4	5	9	3		4	9	7	1		3	2		
Cost	5	4	6	6	4	5	6	7	6	1	7	2	2			3	4	1		
Durability	3		4	7	2	5	5	5	9	7	1	5	7	8				1		
Manufacturability	4	5	3	7				6	2	2	3	6	7	7	1	4	2	2	2	
<b>Technical Requirement Units</b>	Pa*s	kW	-	-	J/gK	kg/m <sup>3</sup>	m <sup>3</sup>	Baker	K	kw/m <sup>2</sup> K	#	BHN	-	-	Hz		m <sup>3</sup>	m <sup>3</sup>	m <sup>3</sup>	
<b>Technical Requirement Targets</b>																				
	1.9	2	3	50	0.6	8	0.2	1	4	10	2	7	0.05	0.95	70	90	0.25	0.009	0.17	
<b>Absolute Technical Importance</b>	119.00	163.00	193.00	69.00	107.00	114.00	210.00	113.00	72.00	109.00	120.00	129.00	136.00	89.00	46.00	65.00	145.00	115.00	115.00	
<b>Relative Technical Importance</b>	8	3	2	17	14	11	1	12	16	13	7	6	5	15	19	18	4	9	9	

\*Phase angles refer to the difference in angle between the two rods, which are connected to the rotating flywheel |

**Figure 1:** House of Quality

The house of quality (HoQ) is used to relate engineering requirements with the customer needs. Namely, the HoQ effectively ranks the correlation between each customer need and engineering requirement, based on a scale from one to nine. On this scale, one is the least related while nine indicates a strong correlation between the ER and the customer need. The absolute technical importance was calculated by first multiplying the score of 1-9 assigned between each ER and customer need, by the corresponding customer weight. After completing the products for one engineering requirement, the absolute technical importance was determined by summing all of the aforementioned products (for each ER).

The HoQ indicates that compression/expansion space is one of the important, since it has that highest absolute technical importance. Other notable ERs that were found to be important with the HoQ are Fin effectiveness and Power input. It is also worth noting that the relative technical importance ranked the ERs on the basis of their absolute technical importance, with one being the most important. With this tool, the team will now focus on optimizing features of our design that are at all related to power input, fin effectiveness and compression/expansion space. These features can be derived intuitively or be based on the HoQ. In the future, ERs can be correlated to themselves to determine how strongly each ER is related to one another.



### **3 EXISTING DESIGNS**

Industrial uses of Stirling cycle cryocoolers is extensive. Examples of existing designs include each of the following system designs including Alpha, Beta, Gamma, and Free piston types. Research focused on each system is described in section 3.1 is followed by system level descriptions and figures that explain each design.

#### ***3.1 Design Research***

Research processes for this project include looking at existing designs kindly provided by our client Dr. David Trevas who loaned a small model of a Stirling engine that operates using an alcohol fueled candle as a heat source. Although the model is an engine, it does help demonstrate the relating features that are included in Stirling coolers such as the piston, displacer, regenerator, and differential heat requirement. A similar, yet more simplistic model, was purchased by the team to help explore various designs.

Viewing demonstrations posted to YouTube have been studied to gain understanding of various processes and applications that have been designed produced for industrial consumption. Many peer reviewed journal articles exist that have been reviewed and referenced along with several books that were obtained from Cline Library. Leading research conducted by Israel Urieli and William Beale Ohio University has been reviewed and referenced extensively since these sources were leading authority and pioneers of Stirling systems as well as personal acquaintances of our client Dr. Trevas.

Benchmarking was guided by interviews with our project mentor, Mr. David Willie. Professor Willie has conducted extensive research on Stirling engines and coolers and was employed by the Sunpower Company that specializes in production of Stirling technologies focusing on environmentally responsible alternatives to power generation and refrigeration applications.

#### ***3.2 System Level***

##### **3.2.1 Existing Design #1: Alpha**

An existing design of alpha engine has been found that depends on two pistons. These two pistons are in vertical shape and both are in downward shape [4]. Alpha engine works on the principle cyclic compression and expansion. The hot piston is larger than the cold piston in this design [4]. These two pistons serve to remove heat from the expansion space. This design will help us in making the Stirling cycle and we can take the concept of this alpha engine design for the implementation of our project. The specific alpha design is shown in the following figure.

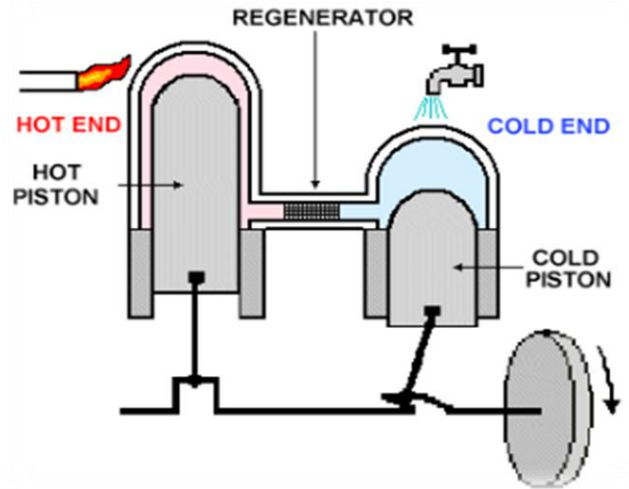
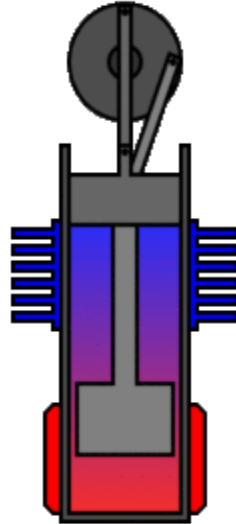

**Figure 2:** Alpha engine existing design 1 [4]

The alpha engine works in the same way as a refrigerator (except in reverse) by compression and expansion of cold and hot reservoirs. The features contained in the alpha engine can be utilized in the project, with some modification, because this engine utilizes the Stirling cycle. Higher compression ratios provided by the alpha engine, which consists of two separate pistons, can be utilized into this project to improve upon the performance of the cycle [4].

This configuration requires the implementation of a flywheel, which is distinguishable from designs that use a linear motor. Additionally, this design does not require the inclusion of a displacer (used in the beta and gamma configurations).

### 3.2.2 Existing Design #2: Beta



**Figure 3:** Beta type Stirling engine [14]

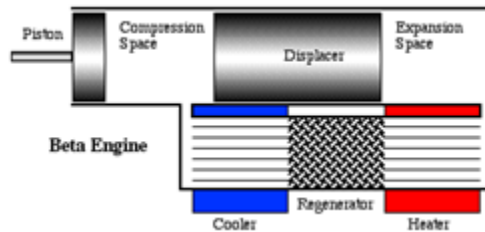

**Figure 4:** Schematic of Beta type Stirling engine [14]

An important early Beta engine is Lehmann's machine on which Gustav Schmidt did the first reasonable analysis for in 1871. Andy Ross built a small working replica of the Lehmann machine, as well as a model air engine, both based on single cylinder Beta configurations. [14]

For the Beta configuration, the piston and displacer share the same cylinder and connected to a flywheel and motor. It does meet the requirements we have for our cryocooler engine to work. For our beta design we would use electric motor as our energy source. Also, we would be using fins to increase the rate of heat transfer.

This beta configuration has a flywheel which provides the rotation to piston that produce the compression and expansion. Flywheel plays the same role in the beta configuration as it plays in other types since its function is to produce rotational motion and cause the piston (and displacer) to move up and down. This design for the beta configuration is useful for our design process and we can further develop and modify the concept of flywheel with the beta configuration for our design.

### 3.2.3 Existing Design #3: Gamma

Another existing design relating to our project is gamma configuration. An existing design of the gamma configuration is shown in the figure below. The gamma configuration is one of four existing designs. It is the simplest design of a Stirling cycle, in which a small piston is used for compression. This configuration consists of a piston moving in the horizontal direction [5]. This configuration is used in other existing designs and is available commercially (to purchase).

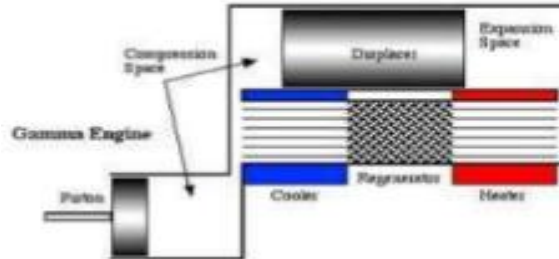

**Figure 5:** Gamma engine existing design 3 [5]

A displacer is used in this design. Its purpose is to induce the motion of the gas and cause the gas to move between the hot and cold reservoir by exploiting the pressure drops induced by the cycle/temperature differential. The power piston is in a separate cylinder which is connected to the other cylinder as to provide a pathway for the fluid.

This design provides a low compression ratio due to its small piston and large dead volume. Furthermore, this configuration has the lowest characteristic efficiency, when compared to the other configurations, in general.

The advantage of this configuration is that there is only one seal, which does serve to satisfy one of our ERs.

### 3.2.4 Existing Design #4: Free Piston

Common cryocooling devices that exist in industry rely on Free Piston Stirling Cooling (FPSC) mechanisms that prove effective and simple in design. These arrangements have fewer moving parts and rely on simplified configurations to achieve effective cooling processes. Existing cryocooler applications that utilize this design include medical specimen transport coolers [7], gas liquification and purification systems [5], aeronautical/space vehicle climate control [6], and carbon dioxide capture [8].

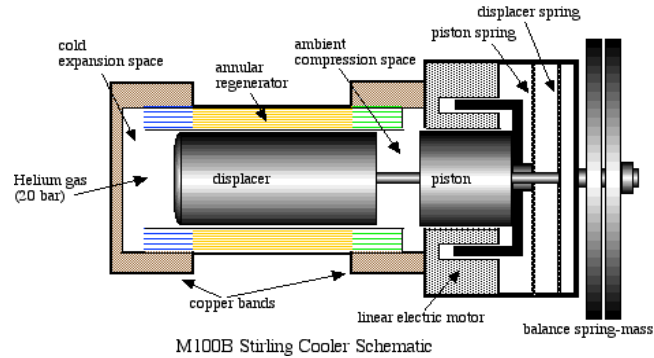

**Figure 6:** Schematic of Free Piston cooler [1].

Free piston designs are relatively simple and require only two moving parts. Figure 6 shows simplified arrangement of a free piston assembly combined with a linear motor configuration. The displacer and piston are linearly oriented along a common shaft while the regeneration process occurs in the annular space surrounding the main cylinder. Helium or air acting as working fluid is shuttled from cold to hot by motion of the displacer by way of the regenerator. Compression is applied by the piston and heat is dissipated and transferred to the surroundings via fins. The gas can expand in the cold space while the heat is removed from the gas in the regenerator media [1]. Springs are attached to the end of the shaft act as shock absorbers and produce a rebounding force to continue reciprocating motion to execute heat removal process.



**Figure 7:** Shuttle ULT-25N Ultra-Low Temperature Freezers, Stirling Ultracold # ULT25EXT (10027-524) - Model ULT-25N [10]

An example of a cooling device that uses Stirling cooling technology is manufactured by the Shuttle company and shown in Figure 7. This product is used for medical transport and provides solid function and proven performance. This design can be used as a benchmarking standard that is applicable to this project. However, the temperature range that this product provides is much

lower than what the customer requirements require. Figure 7 shows the portability and functional cold storage that can be incorporated into this design.

Bench top cryocoolers could be displayed with transparent mounting and equipped with monitoring instrumentation that displays amperage and temperature readings provided by multimeter and thermocouples. Existing arrangements of this type are rare but could be assembled using combinations of necessary devices that can be purchased. Figure 8 shows two critical components, cryocooler and power drive that could be attached to a framework constructed from clear acrylic material.

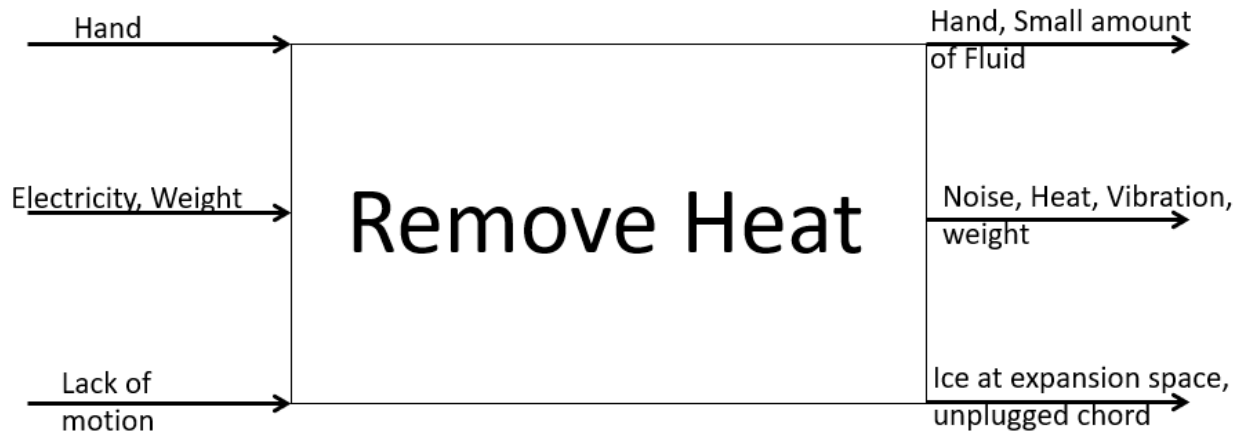

**Figure 8.** Twinbird Corporation, *Stirling Cooler Model: SC-TD08.* [7]

This Stirling cooling process suits the needs of this project to provide ample cooling to meet customer needs. Possible experimental lab assignments using this device include investigations relating power input to temperature change rate, working fluid properties, changing working fluid types, power source alternatives, thermodynamic processes observation and optimization. Simple display and arrangement of this type of cooling system design will easily be displayed in a benchtop configuration and could possibly be constructed from transparent materials that would allow a deeper understanding of the internal movement and function of the Stirling process.

### 3.3 Functional Decomposition

#### 3.3.1 Black Box Model

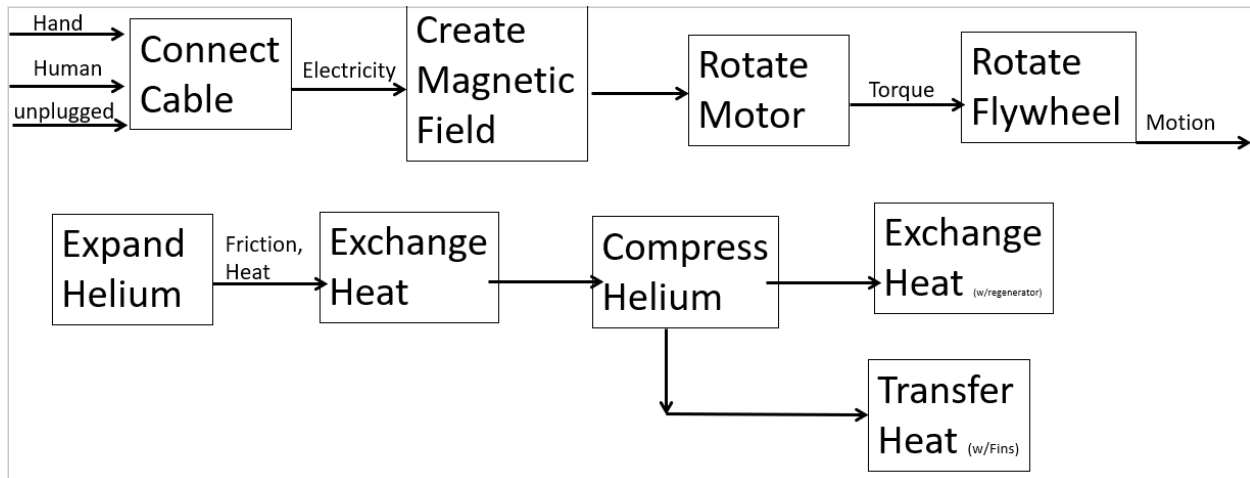

**Figure 9:** Black Box Model

The black box model was developed for a Stirling refrigeration system by first conducting some background research. After understanding a fairly comprehensive overview of the system, the group identified the inputs and outputs of the overall system. The inputs included a hand to plug in the power, electricity to power the motor, the weight to be oriented in an appropriate fashion and the lack of motion to indicate that the system is not in operation. The outputs include hand that is being removed, fluid that is leaking from the system, noise, heat and vibration stemming from the motor/system's imperfections. The presence of ice near the expansion space would indicate that the system worked, and the unplugged chord would indicate that the system is off.

#### 3.3.2 Functional Model

This functional model was developed by using the inputs and outputs from the black box model and expanding on it. The following sequence of events are represented in the Functional Model in Figure X. Namely, cable is connected to the wall in order to supply electricity/energy to the motor, which will create a magnetic field that induces rotational motion. This motion will drive the flywheel and cause a piston to expand the working fluid. The action performed by the piston will lead to energy inefficiencies (i.e. friction & heat) which will affect the system's overall performance. The motion of the flywheel will then induce the motion of the working fluid to travel through the regenerator and exchange heat with the regenerator material. Subsequently, the fluid will be compressed by a piston and will lose energy in the form of heat, through its fins. The cycle then continues by the working fluid being forced through the regenerator again for another exchange of heat.



**Figure 10:** Functional Model

### 3.4 Subsystem Level

Subsystems of the Stirling Cryocooler exist in similar configurations among each system type. Displacers, pistons, seals, regeneration sections, and working fluid are similar for each system and perform the same function in each. The following sections describe in detail the individual working of each subsystem followed by examples of existing designs as they pertain to a Stirling cycle cooling device.

#### 3.4.1 Subsystem #1: Displacer

Stirling cooler designs utilize displacers as a means of transferring the working fluid between the cold and hot regions of the device. The importance of this subsystem is critical to the basic operation of any Stirling engine or cooler. The displacer provides no work since the pressure of the working gas remains constant on either side of the displacer piston [3]. The working gas is transferred from hot to cold zones by ducts that are incorporated within the displacement cylinder that house the regeneration material. Figure 3 shows this system as it applies to a free piston system.

Project requirements are met by including an effective displacer subsystem that plays a key role in the Stirling cooling cycle. Transference of working gas from the hot to cold areas of the assembly along with the position of these zones is critical to the effective cooling characteristics of this model. Movement of the Displacer piston is explained in section (3.4.5.4) referencing the linear motor description. The design of this motion combined with a notably longer size and thinner wall thickness is primarily to isolate the two thermal regions and minimize conduction between the two [4].

#### 3.4.2 Subsystem #2: Piston

Each configuration must achieve the compression stage of the Stirling cycle using a piston that is attached to the reciprocating shaft much like the other systems. Its purpose is to create pressure on the forward stroke and receive force from expanding gas pressure which in turn translates to torque or is absorbed by a spring.



### 3.4.3 Subsystem #3: Flywheel

It is the sub-system in the engine, which rotates with the help of some external source or from the internal source and flywheel uses to rotate the piston connects with it. It stores the rotational energy and it stores the inertia as well during the rotation. Moment of inertia cause the flywheel to keep rotating and moving the piston to create the expansion and compression. Flywheel needs the torque to rotate and that torque provides initially from external source and then because of moment of inertia it needs little amount to torque to keep rotating. It should also be noted that this component is not necessary for every design (e.g. Refrigerator powered by a linear motor).

### 3.4.4 Subsystem #4: Gaskets & Seals

Efficient compression in the free piston system depends on effective seals between the piston and cylinder. This project will require seals that allow enough pressure to conduct the compression stage of the Stirling cycle while offering minimal resistance due to friction. Even the slightest amount of working fluid leakage dramatically decreases the ideal cold production [23]. When common seals like lip and ring seals are used, Stirling refrigerators often are troubled by working fluid leakage past the dynamic seal [21]. This leakage will cause a decrease in the mean pressure of the working fluid, which is known to deteriorate the seals over time, inducing a coupled decrease in the efficiency of the refrigerator [21]. As can be inferred, seals are a vital component in a Stirling refrigerator due to its function in preventing contamination as well as leakage of working fluid.

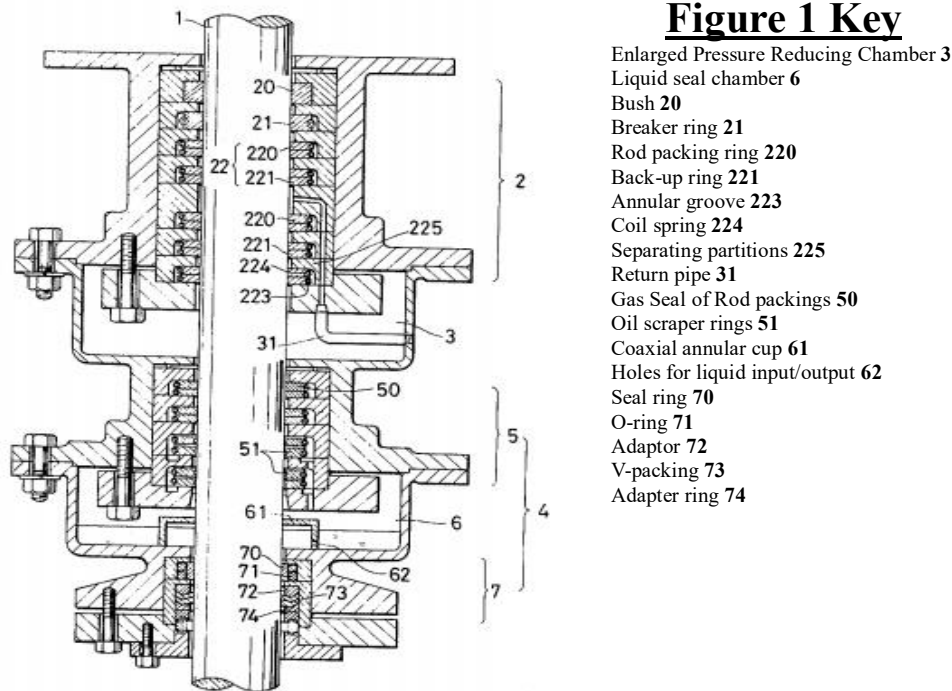

**Figure 11:** Piston Rod Sealing arrangement from Eisuke Sugahara [20]

Figure 7 shows a possible sealing arrangement for a system using a reciprocating Stirling cycle. This arrangement is comprised of a block seal port, a bush, breaker ring, and block seals [20]. The breaker ring is lubricated and helps the bush prevent leakage of the working fluid [20]. The rod packing ring contacts the rod and the back-up ring contacts the rod packing ring [20]. The oil scraper rings contact the piston rod to block the escape of fluid in the liquid seal chamber [20]. The liquid used in the arrangement (specifically in 6) should have a “low affinity for the piston rod material, a high viscosity, and large surface tension” (e.g. Mercury or oil) [20]. It should also be noted that liquid diffusion up the piston rod will be prevented by the oil scraper rings [20]. The most notable aspect about this design is the presence of a gas recirculation system in place to lead leaked gas into the return pipe to a compressor and finally into the working cylinder through the mechanism of a pressure sensitive control valve [20].

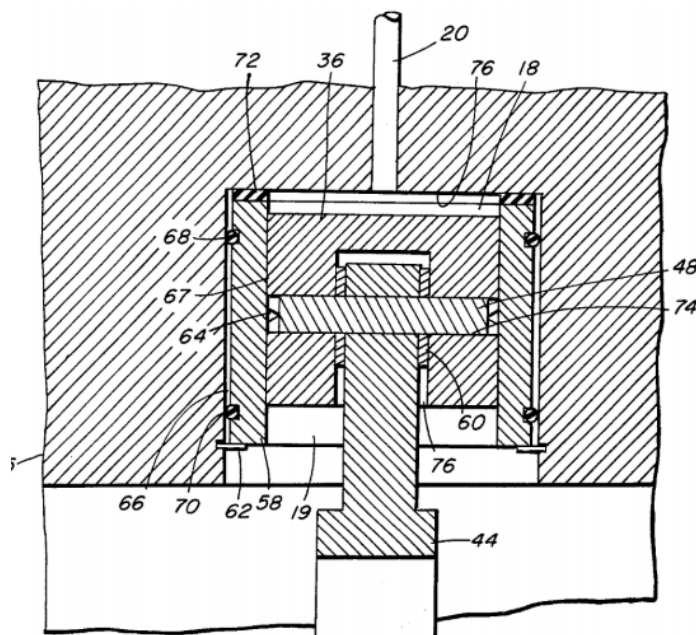

### **Figure 2 Key**

- Working Gas Space 18
- Dead Space Volume 19
- Supply Line 20
- Cermet Piston 36
- Connecting Rod 44
- Wrist Pin 48
- Ceramic Sleeve 58
- Spacers 60
- Snap Ring 62
- Pressure Equalization Groove 64
- Radial Clearance/Gap 66
- Clearance Seal 67
- Gas Blow-by Elastic O-ring 68
- Dead Space Minimizing Elastic O-ring 70
- Sleeve Elastic O-ring 72
- Wrist Pin Bearing 74
- Surface 76

**Figure 12: Clearance Seal & Piston Arrangement Drawing [21]**

Figure 8 above shows an example of a Clearance piston seal invented by Peter Bertsch. The piston is of cermet or ceramic and reciprocates within a ceramic sleeve [21]. The use of ceramic is instrumental in providing a smooth surface, while the radial gap is filled with the working fluid to act as a lubricant and minimize wear [21]. The snap ring keeps the sleeve in place, with some freedom for thermal expansion supplied by the elastic O-rings [21]. The Floating sleeve also serves to absorb some of the load created in the reciprocating motion [21]. This patent also mentions that this mechanism can be used with a displacer in this kind of system, as well [21].

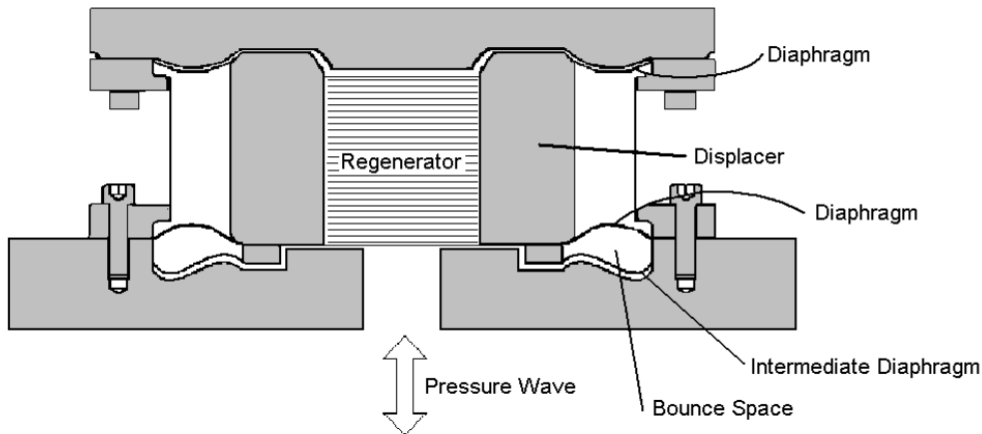

**Figure 13:** *Diaphragm-contained displacer [22]*

The above figure shows an alternative to conventional lip seals and piston rings. Specifically, A. Caughley et al described a “concept of using metallic diaphragms to seal and support the displacer in a free piston Stirling cold head” [22]. This reference describes the diaphragms as functioning to seal and suspend the displacer while also balancing the compressive loads subjected to the displacer [22]. These diaphragms’ stiffness is such that it provides spring-like characteristic to center the displacer [22]. This type of design would minimize the amount of seals we might need, while also eliminating the clearance gaps and rubbing [22].

### 3.4.5 Subsystem #5: Fin Types

For a Stirling refrigeration cycle, the objective is to move heat against a temperature differential. Moving heat against the temperature gradient requires an input of work. The larger the temperature gradient, the more work required to be inputted to the system. To minimize the power consumption of the refrigeration system, one must attempt to maintain and/or decrease the temperature gradient between the hot and cold reservoirs. To prevent the hot reservoir from increasing temperature over the course of the cycle(s), one can implement fins on the outside surface of the hot reservoir. The implementation of fins on this surface will allow for the hot reservoir to dissipate heat to the atmosphere at a high rate, due to fins’ high wetted area. Different fin types can be found in the book *Fundamentals of Heat and Mass Transfer*, where their effectiveness, efficiency, and relevant geometric considerations can be quantified [15].

There are straight, circular and pin fins. While circular fins don’t get any more specific, the straight and pin fins can be rectangular, parabolic or triangular. While parabolic has the highest heat transfer per unit volume compared to the other fins, the manufacturing costs associated with fabricating a parabolic profile outweighs the superior heat transfer rate. Manufacturing costs are why simpler geometries are elected over more complex ones, despite heat dissipation advantages. Figure 14 below shows the different pin fins and their respective geometric considerations.

**Pin Fins**

*Rectangular<sup>b</sup>*

$$A_f = \pi DL_c$$

$$L_c = L + (D/4)$$

$$V = (\pi D^2/4)L$$

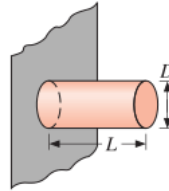

*Triangular<sup>b</sup>*

$$A_f = \frac{\pi D}{2} [L^2 + (D/2)^2]^{1/2}$$

$$V = (\pi/12)D^2L$$

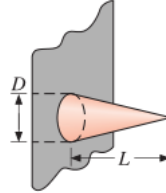

*Parabolic<sup>b</sup>*

$$A_f = \frac{\pi L^3}{8D} \{C_3 C_4 - \frac{L}{2D} \ln [(2DC_4/L) + C_3]\}$$

$$C_3 = 1 + 2(D/L)^2$$

$$C_4 = [1 + (D/L)^2]^{1/2}$$

$$V = (\pi/20)D^2 L$$

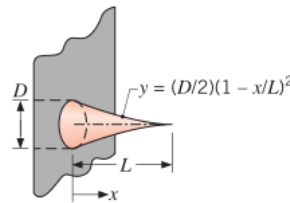



---

<sup>a</sup> $m = (2h/kt)^{1/2}$ .  
<sup>b</sup> $m = (4h/kD)^{1/2}$ .

**Figure 14:** Pin Fin Variations. [15]

**3.4.6 Subsystem #5: Linear/Rotary Motor**

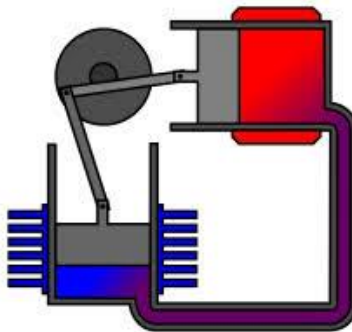
Using a linear motor is a common source of piston actuation in free piston system. Many types of linear type electric motors are available with a range of actuation displacement. This project proposes either the use of a high efficiency, small volume, linear motor (Figure 11) or a rotary motor that utilizes that would require a flywheel and connector rods (Figure 10). Both types are feasible however the linear motor would allow for a more compact “built-in” aspect rather than an extensive connection assembly that requires more space, parts and ultimately, cost.



**Figure 15:** Idealized flywheel, connectors, piston and displacer assembly for Alpha system. [13]

Piston actuation is the primary goal of either the linear or rotational electric motor. Displacer

and piston motion generally actuate in a synchronized and unilateral manner. A rotational motor type is feasible to reach system design requirements for the Alpha, Beta, and Gamma configurations. Since they rely on separate piston/cylinder configurations requiring connector arms attached to a flywheel. The Free Piston system commonly uses linear motors to achieve shaft motion that results in piston/displacer motion (Figure 4).

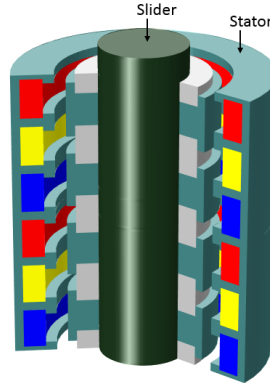

**Figure 16:** A 3D view of the tubular generator [12]

Electrical needs for this project place motor requirements to be able to receive power from a standard 120 volt alternating current outlet. Project variations may require motors that could utilize 12v direct current that allows for either solar or vehicular alternative power sources.

### **3.4.7 Subsystem #6: Regenerator Material**

The regenerator in a Stirling refrigeration system serves to act as a thermal sponge in the scheme of the cycle. Namely, the regenerator matrix will function to accept heat from the working fluid when it is translating from the hot reservoir (compression space) to the cold reservoir (expansion space) and reject heat to the working fluid when it is moving in the opposite direction (expansion to compression space). As such, properties that are relevant to the optimization of this system include heat capacity, porosity, and density of the regenerator material. Additionally, the size of the regenerator and the viscosity of the working fluid will certainly affect the regenerator's performance.

It should also be noted that the regenerator is one of the most important components in a Stirling refrigerator. Namely, the regenerator is typically the largest source of power loss in the system, due to "Axial heat conduction, imperfect gas-solid heat transfer, and frictional losses" [16].

The heat capacity of the regenerator material should be maximized as to maximize the amount of heat energy extracted from the working fluid and by extension, to minimize the temperature of the working fluid when it enters the expansion space. Conversely, a high heat capacity of the regenerator material will also allow for more heat energy to be potentially transferred to the working fluid on its path to the compression space, where heat dissipation to the environment will be exploited using fins.

It is known that the pressure drop across a porous media is related to the viscosity & porosity of the solid phase [16]. Namely, the higher the viscosity, the higher the associated pressure drop. This relation is provided below in Equation 1, where the above proportions can be extracted from. It should be noted that pressure drops are associated with an increase in power

consumption, which is not desirable [16].

$$\frac{dp}{dx} = -\frac{\mu}{K} \varepsilon u + \frac{c_f \rho}{\sqrt{K}} \varepsilon^2 u |u| \quad \text{Equation 1 [16]}$$

Additionally, the above equation states that density is directly proportional to the pressure drop, which might indicate that we want to minimize the density. Increasing the density will also increase the heat capacity of the solid phase as well as the working fluid's flow impedance. With opposing property optimizations, the density will be optimized by paying attention to the other optimizable characteristics and properties of the system.

Porosity should be maximized to decrease flow impedance and to maximize the rate at which heat is transferred to and from the solid phase. Equation A also indicates that the pressure drop magnitude increases as porosity increases. Moreover, minimizing the size of the regenerator subsystem will minimize the heat dissipation from the system to the atmosphere (heat leakage), minimize the flow impedance that the working fluid is subjected to (through the regenerator material's boundary layers) and minimize the dead volume, which is directly related to the overall efficiency of the refrigeration. It should also be noted that the longer the regenerator, the bigger the pressure drop across the regenerator [16].

There are a variety of different materials and configurations used in regenerators. Examples of solid matrices used in regenerators include wire-mesh screens, perforated disks, spherical powders, foam metal, foils and composites [16]. Wire mesh screens are the most common among Stirling refrigerators, which come in two varieties: plain and twill [16].

As far as optimizing the geometric considerations of a wire-mesh screen are concerned, the length and diameter of the wire are the relevant dimensions with respect to the regenerator's performance.

Namely, as the ratio of the length to the diameter of the wire  $\left(\frac{L_w}{D_w}\right)$  increases, the convective heat transfer coefficient and area increase. The increase in the convective heat transfer coefficient and area also indicates that there will be a corresponding increase in the heat transfer from the fluid to the solid (and vice-versa) [16]. Additionally, increasing the wire diameter at a given  $\frac{L_w}{D_w}$  ratio and decreasing the  $\frac{L_w}{D_w}$  ratio at a given wire diameter results in a decrease in the frictional power dissipation and compressor power consumption. As wire diameter increases, the compressor's power consumption decreases while the pressure drop's magnitude will increase due to an increase in porosity for larger wire diameters [16]. These contrasting relations infer the fact that for a given  $\frac{L_w}{D_w}$  ratio, there exists a unique wire diameter that corresponds to a maximum value for the coefficient of performance (COP) [16].

NASA's contract report ("Composite Matrix Regenerator for Stirling Engines") provides the following tables that shows the relevant material properties for different regenerator materials:

**Table 2** Material Properties of Selected Regenerator Materials at T = 750K [17]

Material	$k$	$d$	$c_p$	$c$	$kc$	$k/c$	$kc$	$k/c$
	(W/K-cm)	(g/cm <sup>3</sup> )	(J/g-K)	(J/cm <sup>3</sup> -K)			(normalized to steel)	
Stainless Steel	0.14	8.00	0.66	5.28	0.74	0.027	1.00	1.00
Graphite (crystal)	5.20	2.10	1.81	3.80	19.77	1.368	26.74	51.60
Carbon (amorphous)	0.02	2.10	1.81	3.80	0.09	0.006	0.12	0.24
Silicon	0.30	2.33	0.94	2.19	0.66	0.137	0.89	5.16
Boron	0.06	2.34	2.32	5.44	0.34	0.011	0.46	0.43
Beryllium	0.87	1.85	3.05	5.64	4.90	0.154	6.63	5.80
50%Graphite/Carbon	2.61	2.10	1.81	3.80	9.93	0.687	13.43	25.92
50%Graphite/Boron	2.63	2.22	2.08	4.62	12.15	0.570	16.44	21.48
50%Graphite/Silicon	2.75	2.22	1.35	3.00	8.24	0.918	11.15	34.61

**Table 3** Carbon and Steel Thermal Properties [17]

Material	heat capacity (J/K-g)	thermal conductivity (W/K-m)	density (kg/m <sup>3</sup> )
felt carbon	0.712	0.035	1570
316 stainless steel	0.494	16.23	9058
Inconel-600	0.456	15.00	8498

According to Q. Zhou, L. Chen et al,  $Er_3Ni$  is a great material for regenerators operating at a temperature of 20 K because of its high ratio of thermal conductivity to specific heat capacity [18]. Its thermal diffusivity is comparable to that of a stainless-steel wire mesh, while its flow resistance is much larger than that of a stainless-steel wire mesh (especially for spheres with diameters less than 100  $\mu\text{m}$ ) [18]. Finally, Q. Zhou, L. Chen et al compared 500-mesh SS plus 9mm  $Er_3Ni$  to 500-mesh SS and the following results were obtained [18]:

**Table 4** Performance of Different Regenerators [18]

Regenerator materials	no-load temperature	Optimum frequency
	K	Hz
500-mesh SS	17.4	35.5
500-mesh SS+ $Er_3Ni$	16.5	31.5

M. Tanaka, I. Yamashita, and F. Chisaka presented the geometric parameters relevant for the different regenerator materials they investigated, which are provided below in Table 5.

**Table 5** Tested Regenerator Materials [18]

Material	Symbol	Dia. (mm)	Porosity* (-)	Porosity** (-)
Wire Netting	WN 50	0.23	0.645	
	WN100	0.10	0.711	
	WN150	0.06	0.754	
	WN200	0.05	0.729	
Sponge Metal	SM15	0.30	0.956	0.920
	SM30	0.14	0.936	0.897
	SM50	0.08	0.940	0.903
	SM50a	0.08	0.887	0.806
	SM50b	0.08	0.819	0.702
	SB	0.45	0.372	

\* Calculated from bulk density

\*\* Calculated from water replacement

Finally, Table 6 shows more materials that could be used for the regenerator, which was taken directly from the literature [19].

**Table 6** Additional Regenerator Material Properties [19]

Matrix no.	1	2	3	4	5
Material	Stainless steel screens mesh #400	+ Cu screens mesh #80	+ Brass screens mesh #353	+ Perforated Cu-plates	+ Brass screens + perforated Cu-plates
Length fraction (%)	100	50	45	4	15 + 2
Porosity of added component	0.59*	0.62	0.62	0.20	0.62 0.20
Total radial conductivity at 100 K (W/m K)	3	89	15	18	25
Total axial conductivity at 100 K (W/m K)	0.7	1.4	1.3	0.8	0.9



## 4 DESIGNS CONSIDERED

### 4.1 Design #1: Benchtop Apparatus

This idea incorporates a recreation of existing Stirling cooler apparatus and incorporates a framework that the unit is mounted to. Power would be provided from a standard 120-volt outlet to power a linear motor connected to the free piston system as described in section 3.2.4. The device would be arranged so that multiple thermocouples could be attached at both cold and hot regions of the cooler. Voltage, amperage, and motor speed monitors including digital readout will be mounted to the frame assembly. Motor speed will be regulated using a variable frequency drive (VFD) attached to the frame.

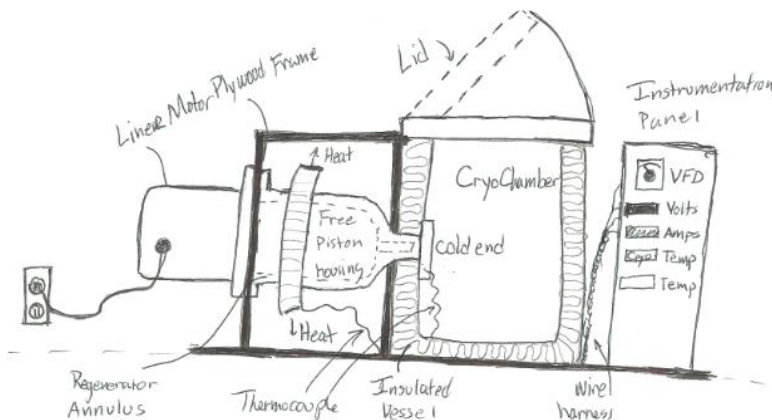
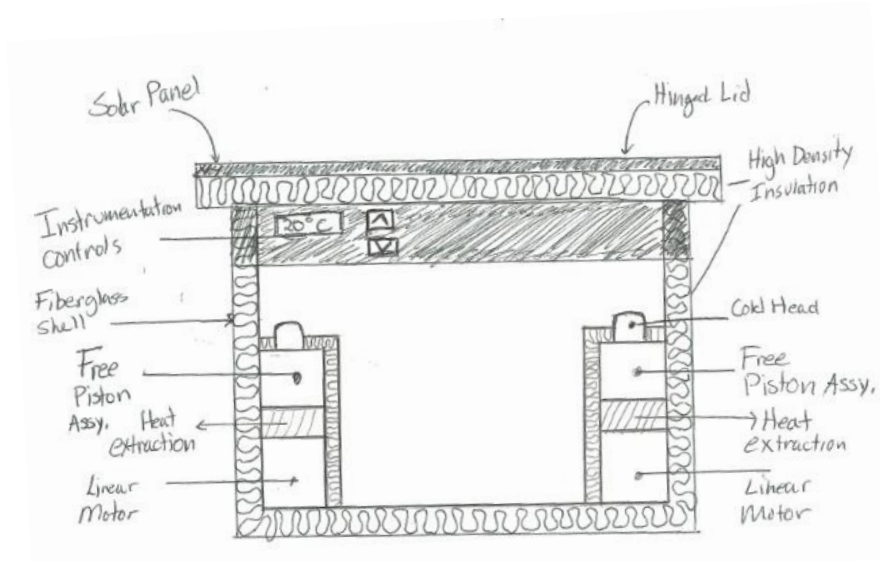

**Figure 17:** Benchtop concept with instrumentation panel and cold chamber.

Advantages of this design include functionality as a demonstration tool, efficiency regarding fewer moving parts, portability, and adaptable to different experiment designs. Data can be gathered from multiple thermocouples placed in critical locations along with voltage inputs from the motor. This data can be compiled by LabVIEW software that can be directly monitored via USB or better port. Disadvantages would begin with a high cost of materials and instrumentation components. Complication of connections and proper power sizing, transformers, VFD drive requirement would also add to difficulty of successful design.

## 4.2 Design #2: Solar powered Ice-Chest

Creation of cold space in sunny hot environments can be accomplished using a solar powered Free Piston Cryocooler. This design would require a very well insulated, air tight, cooling vessel that incorporates one or more linear motor actuated Stirling coolers. Solar panels that are attached to the cooler lid would provide power to the linear motor(s) and any other control instruments.



**Figure 18:** Solar powered Ice-Chest.

Self-sustaining cooling using solar radiation is a challenge that would be met by this design concept with vigor. Having the ability to generate low power consuming electric motors and eliminating dangerous refrigerants, complete freedom to keep items cold would be achieved. Advances in motor efficiency, thermo insulation, and photovoltaic panels could make this design feasible. Challenges include keeping consistent temperatures when sun is not present. Utilization of specialized insulating materials that are efficient enough to keep constant temperatures. Weight of the cooler in addition to contents, and cost.

### 4.3 Design #3: Dual Piston Cryocooler

This is a design in which there are two pistons connecting with the heat exchanger. A cold finger with the bouncing volume attach with the displacer, when the piston moves by the source of heat it creates the compression and expansion and cause the displacer to generate the power. The pros of this design are high power, low cost, and easy to operate. The con is that this design is less efficient. It can see in the following figure

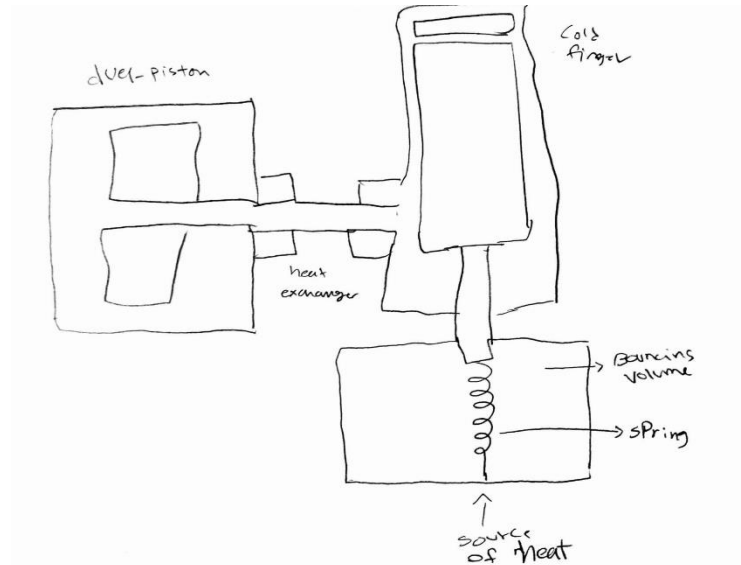

Figure 19: Dual piston

### 4.4 Design #4: Inline regenerative cryocooler

In this design concept, there is a regenerator with the cooler in the single line, it has heat input and heat output with the displacer. In this system, the displacer connects with the heat input and the piston is in opposite to the displacer. Heat rejection is the excess heat from a cooler system. Heat rejection is the total amount of heat energy which is transferred from the cool side to the warm side. All the parts are in the same line therefore it provides the cryocooler with easy operation and it provides high power with less consumption of fuel. The pros of this design are small and low in cost. The con of this design is that it has less power production.

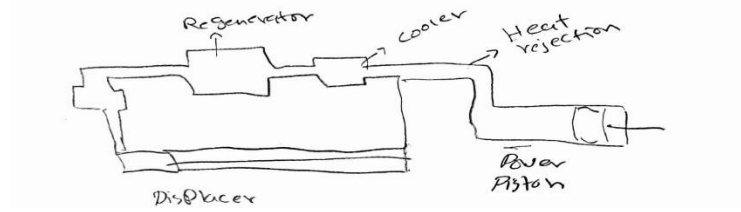

Figure 20: Inline regenerative cryocooler

## 5 DESIGN SELECTED – First Semester

In this is chapter the best design will be selected based on the pugh chart and the decision matrix among all ten considered design that the team came up with. Below are the pugh chart and the decision matrix analysis.

### 5.1 Rationale for Design Selection

**Table 7** Pugh Chart

	Transfers Heat	Manufacturability/Size	Minimizes Seals	Power Input	Sum of +	Sum of -	Sum of S
Design 1	+	-	s	+	2	1	1
Design 2	+	-	-	s	1	2	1
Design 3	-	s	s	+	1	1	2
Design 4	s	s	-	+	1	1	2
Design 5	-	S	+	-	1	2	1
Design 6	S	S	-	+	1	1	2
Design 7	+	+	S	S	2	1	2
Design 8	\	\	\	\	\	\	\
Design 9	s	s	-	+	1	1	2
Design 10	+	-	-	s	1	2	1

**Table 8** Decision Matrix

		Sketch #1		Sketch #2		Sketch #7	
Criteria (Objectives)	Weight (100 %)	Score (Out of 1)	Weighted Score	Score (Out of 1)	Weighted Score	Score (Out of 1)	Weighted Score
Transfers Heat	35	0.75	26.25	0.75	26.25	0.75	26.25
Cost	25	0.5	12.5	0.25	6.25	0.75	18.75
Power Input	25	1	25	0.5	12.5	0.25	6.25
Size	15	0.5	7.5	0.25	3.75	0.25	3.75
Total	100 %		71.5		48.75		55

First, we created the pugh chart and tried to evaluate all ten considered designs to select the best three designs that we will be focusing on in our decision matrix. These designs were evaluated based on their heat transfer, Manufacturability/Size, number seals, and power input. Design one (Benchtop Apparatus) was selected to be considered as the best design. Evaluating designs 1, 2 and 7 in the decision matrix led us to the fact that design one's power input and heat transfer is the best, compared to two and seven.

The advantage of using this free piston design is the power we can get from the electric linear motor that is connected to it is much simpler than that of a rotary motor. Additionally, this design will

## 6 APPENDICES

### [Appendix A: References

- [1] I. Urieli, "Chapter 3b - The First Law - Closed Systems - Stirling Engines (updated 7/5/2014)", *Ohio.edu*, 2018. [Online]. Available: [https://www.ohio.edu/mechanical/thermo/Intro/Chapt.1\\_6/Chapter3b.html](https://www.ohio.edu/mechanical/thermo/Intro/Chapt.1_6/Chapter3b.html). [Accessed: 24- Jun- 2018]
- [2] Y. Guo, Y. Chao, Z. Gan, S. Li and B. Wang, "Performance analysis on free-piston Stirling cryocooler based on an idealized mathematical model", *IOP Conference Series: Materials Science and Engineering*, vol. 278, p. 012174, 2017.
- [3] C. West, *Principles and applications of Stirling engines*. New York: Van Nostrand Reinhold, 1986.
- [4] G. Walker, G. Reader, O. Fauvel and E. Bingham, *The Stirling alternative*. Yverdon, Switzerland: Gordon and Breach Science Publishers, 1994.
- [5] "SGC-4000HG: Stirling Gas Cooler - Apex Instruments", *Apex Instruments*, 2018. [Online]. Available: <http://www.apexinst.com/product/sgc-4000hg>. [Accessed: 24- Jun- 2018]
- [6] E. Loktionov, A. Martirosyan and M. Shcherbina, "Solar Powered Free-Piston Stirling – Linear Alternator Module for the Lunar Base", 2018.
- [7] Twinbird Corporation, *Stirling Cooler Model: SC-TD08*. 2018 [Online]. Available: [http://file:///C:/Users/johnTwiley/Desktop/Free%20Piston/manual\\_SC-TD08.pdf](http://file:///C:/Users/johnTwiley/Desktop/Free%20Piston/manual_SC-TD08.pdf). [Accessed: 24- Jun- 2018]
- [8] C. Song, J. Lu and Y. Kitamura, "Study on the COP of free piston Stirling cooler (FPSC) in the anti-sublimation CO<sub>2</sub> capture process", *Renewable Energy*, vol. 74, pp. 948-954, 2015.
- [9] W. Martini, National Aeronautics and Space Administration, "Stirling Engine Manual", Richland, Washington, 1983
- [10] "GLOBAL Accessory for Shuttle ULT-25N Ultra-Low Temperature Freezers, Stirling Ultracold # ULT25EXT ( 10027-524 ) - Model ULT-25N One-Year Warranty, Each", *Careforde Scientific*, 2018. [Online].
- [11] Z. Wengeng, Z. Yuejin, Z. Zhou and S. Wei, "Design and study of a novel linear motor for Stirling Cryocooler", 2018. Research Institute under China Electronics Technology Company, China 2 School of Mechatronics and Automation, Shanghai University, China
- [12] "Modeling Linear Motors or Generators in COMSOL Multiphysics", COMSOL Multiphysics©, 2018. [Online]. Available: <https://www.comsol.com/blogs/modeling-linear-motors-or-generators-in-comsol-multiphysics/>. [Accessed: 27- Jun- 2018]
- [13] "Stirling engine", *En.wikipedia.org*, 2018. [Online]. Available: [https://en.wikipedia.org/wiki/Stirling\\_engine](https://en.wikipedia.org/wiki/Stirling_engine). [Accessed: 27- Jun- 2018]
- [14] I. Urieli, "Beta Type Stirling Engines - updated 12/30/2011," Stirling Cycle Machine Analysis, 2010. [Online]. Available: <https://www.ohio.edu/mechanical/stirling/>. [Accessed: 28- Jun-2018].
- [15] T. L. Bergman, A. S. Lavine, F. P. Incropera, and D. P. Dewitt, *Fundamentals of heat and mass transfer*. New York, NY: John Wiley & Sons, 2011.

- [16] A. Boroujerdi and M. Esmaeili, “Characterization of the frictional losses and heat transfer of oscillatory viscous flow through wire-mesh regenerators,” *Alexandria Engineering Journal*, vol. 54, no. 4, pp. 787–794, Jun. 2015.
- [17] T. R. Knowles, “Composite Matrix Regenerator for Stirling Engines,” NASA, San Diego, CA, rep., 1997
- [18] Q. Zhou, L. Chen, C. Pan, Y. Zhou, and J. Wang, “Experimental Investigation on Regenerator Materials of Stirling-type Pulse-tube Refrigerator Working at 20K,” *Physics Procedia*, vol. 67, pp. 530–535, 2015.
- [19] M. Dietrich, L. Yang, and G. Thummes, “High-power Stirling-type pulse tube cryocooler: Observation and reduction of regenerator temperature-inhomogeneities,” *Cryogenics*, vol. 47, no. 5-6, pp. 306–314, Mar. 2007.
- [20] E. Sugahara, “PISTON ROD SEALING ARRANGEMENT FOR A STIRLING ENGINE,” 06-Jun-1978.
- [21] P. Bertsch, “CLEARANCE SEALS AND PISTON FOR CRYOGENIC REFRIGERATOR COMPRESSORS,” 11-Mar-1986
- [22] A. Caughley, A. Tucker, M. Gschwendtner, and M. Sellier, “Novel diaphragm based Stirling cryocooler,” *American Institute of Physics*, pp. 667–674, 2012.
- [23] J. W. L. Köhler, “The Stirling Refrigeration Cycle,” *Scientific American*, vol. 212, no. 4, pp. 119–127, 1965.

### 6.1 Design #5: Top Line Cryocooler

In this concept design a building shape system has piston, compressor, and it has a displacer on one side. When the piston will move the displacer will get the compression and expansion from the tube. There is a regenerator and displacer working together in this system to produce the power. The pros of this design are high power production, fuel efficient, less energy consumption, and high generation, and the con is high cost.

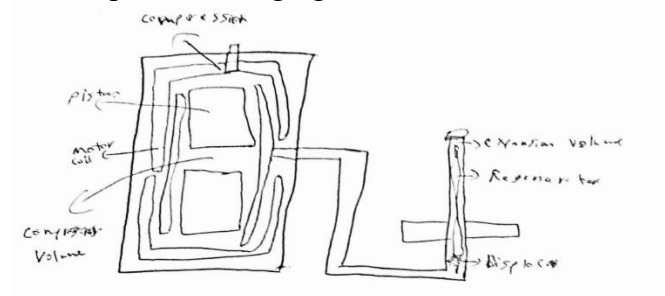

**Figure 21:** Top line Cryocooler

## 6.2 Design #6: Hut form cryocooler

The design is showing below in which a hut form system is showing with one piston and two compressor volumes. The advantage of this design is that it has the piston at top with the displacer connected directly with the piston through the tube. So, the power can easily generate in this design without utilizing high energy. The pros of this design are high power, efficient, and piston connects with displacer directly, and the cons are high cost, and larger in size.

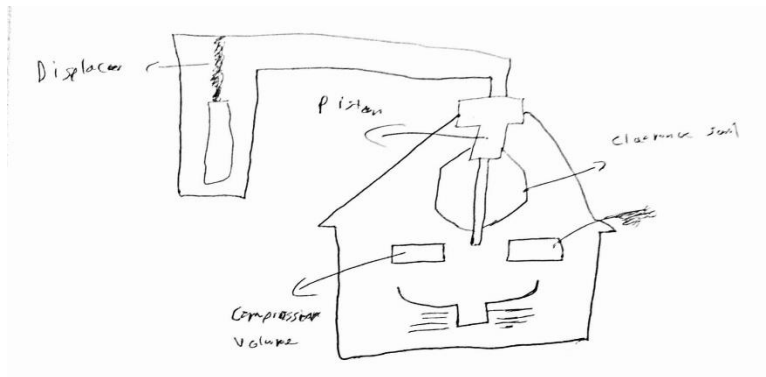

**Figure 22:** Hut form cryocooler

## 6.3 Design #7: Alpha-shaped cryocooler

There is one piston and displacer connected directly to each other. The flywheel moves the piston and that piston produce the compression in between the displacer. The design is showing below, which has the flywheel to produce the expansion and compression like the alpha engine. The pros of this design are high power, and efficient energy consumption and production. The con of this design is high cost.

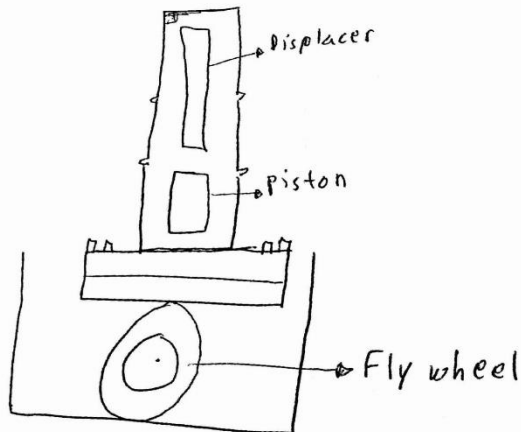

**Figure 23:** Alpha shaped cryocooler



#### 6.4 Design #8: Active cryocooler

In this design concept, the idea is to use the flywheel to move the piston, with the double side heat sink. In this idea, displacer has placed above the piston and the flywheel has connected with both the displacer and piston for rotating both at the same time. The concept is showing below. The pro of this design is highly efficient, and the cons are less power, and high cost.

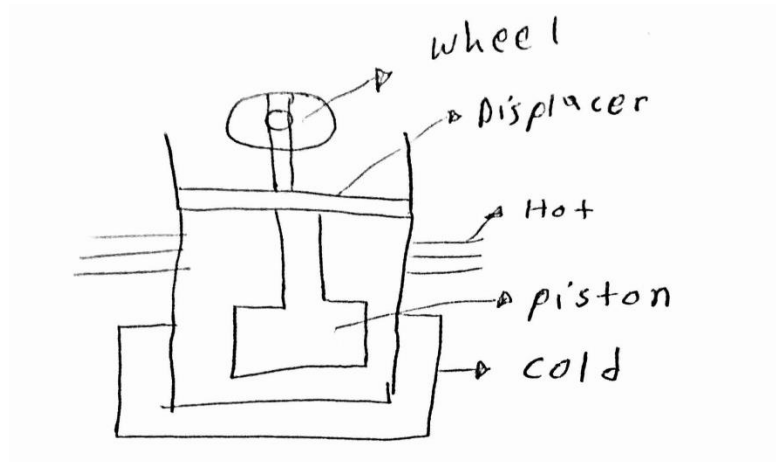

Figure 24. Active Cryocooler

#### 6.5 Design #9: Double Regenerated Cooler

This design is a variation of the alpha configuration. This design uses two regenerators instead of one to maximize the heat conserved by the cycle. This design also uses a flywheel, which is connected to a motor, to induce motion of the pistons. The disadvantages of this design are that a second regenerator introduces another source for heat dissipation. Another disadvantage would be that fact that it would add more to the cost of the device and more work in the analysis of the system.

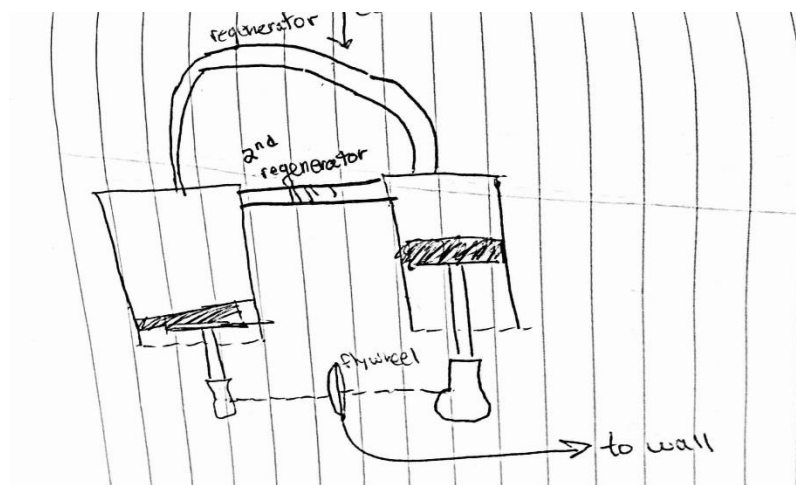

Figure 25: Design 9

### 6.6 Design #10: Water Cooled Compressor Cooler

This design is a variation of the beta configuration. Namely, it uses a linear motor to mechanically induce motion of the displacer and piston. This design uses stainless steel wire mesh for the regenerator material and has pipe surrounding the compression space that is constantly running with water, to remove more heat. The advantage of this design would be that the heat is being dissipated from the compressor at a faster rate, which would implicate less power consumption. The disadvantage of this design would be that more power would be inherently required to power the water pump.

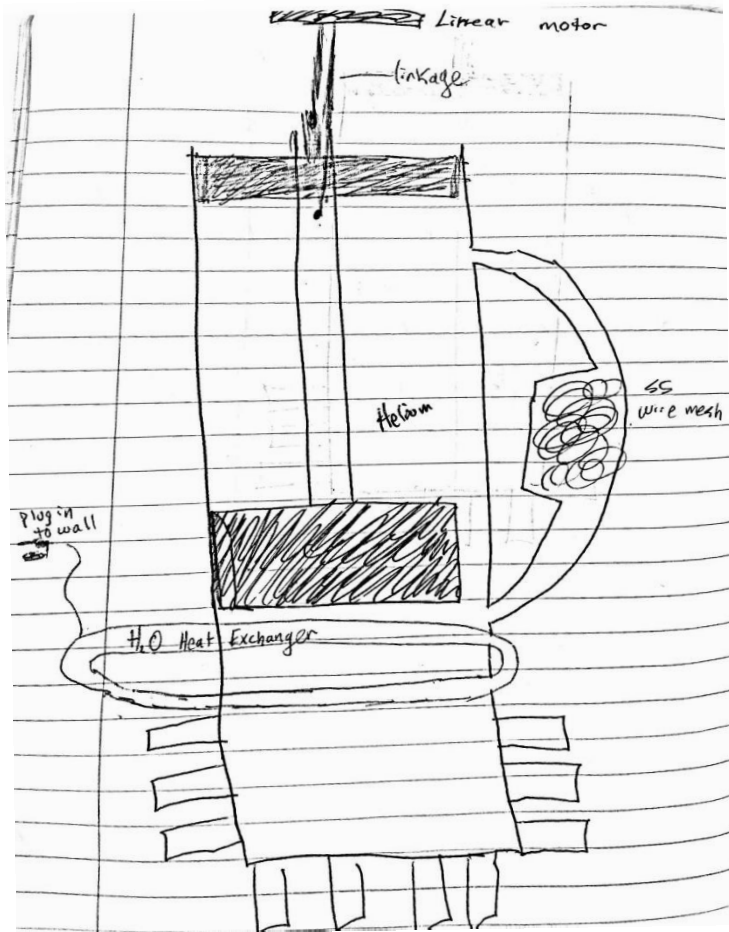

Figure 26: Design 10