

# GoBabyGo A Team 14

## Midpoint Report

**Abdullah Alajmi**

**Abdulrahman Almutairi**

**Ernes Distajo**

**Mohammad Aljuaidi**

**Samuel Williams**

2016-17



**NORTHERN  
ARIZONA  
UNIVERSITY**



**Project Sponsor: NAU ME Dept. & W.L. Gore and Associates**

**Faculty Advisor: Dr. Sarah Oman**

**Sponsor Mentor: Dr. Sarah Oman**

**Instructor: Dr. Sarah Oman**

## **DISCLAIMER**

This report was prepared by students as part of a university course requirement. While considerable effort has been put into the project, it is not the work of licensed engineers and has not undergone the extensive verification that is common in the profession. The information, data, conclusions, and content of this report should not be relied on or utilized without thorough, independent testing and verification. University faculty members may have been associated with this project as advisors, sponsors, or course instructors, but as such they are not responsible for the accuracy of results or conclusions.

# TABLE OF CONTENTS

## DISCLAIMER

## TABLE OF CONTENTS

<b>1. BACKGROUND.....</b>	<b>5</b>
1.1 INTRODUCTION .....	5
1.2 PROJECT DESCRIPTION .....	5
1.3 ORIGINAL SYSTEM .....	5-8
1.3.1 Original System Structure .....	6
1.3.2 Original System Operation .....	7
1.3.3 Original System Performance .....	7-8
1.3.4 Original System Deficiencies .....	8
<b>2. REQUIREMENTS.....</b>	<b>9</b>
2.1 CUSTOMER REQUIREMENTS .....	9-11
2.2 ENGINEERING REQUIREMENTS .....	11-12
2.3 TESTING PROCEDURES .....	12-13
2.4 DESIGN LINKS.....	13-14
2.5 HOUSE OF QUALITY.....	14-15
<b>3. EXISTING DESIGNS.....</b>	<b>15</b>
3.1 DESIGN RESEARCH .....	15-17
3.2 SYSTEM LEVEL .....	17
3.2.1 Existing Design #1: The Ultimate Toy Hack .....	17
3.2.2 Existing Design #2: Electric Car Jeep .....	18
3.2.3 Existing Design #3: Baby Mobility Robot .....	18-19
3.3 SUBSYSTEM LEVEL .....	19
3.3.1 Subsystem #1: Modifying or Creating a New Steering System .....	19
3.3.1.1 Existing Design #1: Mobility Assisted Driving Devices .....	19
3.3.1.2 Existing Design #2: Atari joystick .....	20
3.3.1.3 Existing Design #3: Learning by Leaning .....	21
3.3.2 Subsystem #2: Governing the Acceleration .....	21
3.3.2.1 Existing Design #1: A Shift Selector .....	21
3.3.2.2 Existing Design #2: DIY Remote Control Car .....	22
3.3.2.3 Existing Design #3: Different Tires and Reducing the Weight .....	22-23
3.3.3 Subsystem #3: Accessibility .....	23
3.3.3.1 Existing Design #1: Hand Controls .....	23
3.3.3.2 Existing Design #2: Seating Solution .....	24
3.3.3.3 Existing Design #3: Scoot .....	24
<b>4. DESIGNS CONSIDERED.....</b>	<b>25</b>
4.1 FUNCTIONAL MODEL .....	25
4.2 DESIGN #1: BELLY CAR.....	25-26
4.3 DESIGN #2: LAYING DOWN CAR .....	26
4.4 DESIGN #3: ROUNDED BASE CAR .....	27
4.5 DESIGN #4: TWO BUTTON CAR .....	27
4.6 DESIGN #5: SPRING CAR.....	28
4.7 DESIGN #6: DRAG CAR.....	28
4.8 DESIGN #7: SNAIL CAR.....	29
4.9 DESIGN #8: GRASSHOPPER CAR .....	29
4.10 DESIGN #9: OSTRICH CAR .....	30
4.11 DESIGN #10: G-HARNESSES/SENSOR CAR .....	30

**5. DESIGN SELECTED.....31**

5.1 RATIONALE FOR DESIGN SELECTED .....31-32

5.2 DESIGN DESCRIPTION .....33

    5.2.1 *Website Analysis* .....33

    5.2.2 *CAD Package Analysis* .....33-34

    5.2.3 *Plausibility Analysis* .....34

    5.2.4 *Cost Analysis* .....34

    5.2.5 *Material Analysis* .....34-35

**6. PROPOSED DESIGN.....35**

BILL OF MATERIALS.....36

FINAL DESIGN CAD DRAWINGS .....37

**7. IMPLEMENTATION.....38**

7.1 DESIGN CHANGES .....38-40

7.2 DESIGN OF EXPERIMENT.....40-41

**REFERENCES.....42-43**

**APPENDICES.....44-64**

APPENDIX A: CHARTS.....44-46

APPENDIX B: ANALYTICAL REPORTS .....47-64

# 1 BACKGROUND

Research was conducted in order to better understand the project presented. This project can be broken down into its structure, operation, performance and deficiencies. The following is the base information on which this project is constructed upon and helps to dictate the direction that the team has chosen to pursue.

## 1.1 Introduction

According to the United States Census Bureau there are “53.9 million school-aged children (ages 5 to 17) in the U.S. civilian noninstitutionalized population, about 2.8 million (5.2 percent) were reported to have a disability in 2010” [1]. Many of these children live with physically debilitating disabilities that affect their daily life. These disabilities range from minimal to severe physical barriers; spina bifida, cerebral palsy, down syndrome, hypotonia, and etc. GBG’s (Go Baby Go) purpose is to “foster [the children’s] physical and cognitive development” [2] through the use of an assistive vehicle. The goal of the team is to create an adaptable product that can be easily modified depending on the child’s need. The team believes that it is important for children with limited mobility to be able to interact with the world through their own hands. Therefore, the product must not be very restricting but must also provide enough securement and support options. The team is also looking to create a product that will add a new dimension of safety and operation for the child and their parent.

## 1.2 Project Description

Following is the original project description provided by the sponsor:

“Children with limited mobility often do not receive the much needed exposure to socialization to appropriately cognitively develop. Existing research shows that enabling young children with self-control of their own environment can have meaningful impacts on the long term outcomes given such impairments as cerebral palsy or muscular dystrophy. The Go Baby Go (GBG) project that started at the University of Delaware has developed a set of DIY cars for families with children with mobility restrictions. These cars have been designed on commercially available ride on toy car platforms (like Power Wheels) and have been deployed worldwide by the GBG team. These cars have shown to be a cost-effective means of enabling young children to move and interact with their peers.

The goal of this project will be to design and build a new version of the GBG retrofits – specifically to design a universal control for children that extremely limited mobility of their arms and/or legs [3].”

This team hopes to take the platform of cars and previous designs and create something unique that will not only be adaptable to children with a variety of disabilities, but provides them with a new tool to develop more upon their cognitive, social, and physical skills.

## 1.3 Original System

This project is a re-engineering project that will take past designs and redesign, add and hopefully improve upon them to better fit the children and families using them. The original system of GBG ride-on cars can be broken down into four sections, the structure, operation, performance, and deficiencies.



*Figure 1: Original System [4]*

### **1.3.1 Original System Structure**

The base for practically all GBG ride-on cars is a single person power wheels car; depending on the car, it may be rated for kids 12-36 months up to 40 lbs or 2-6 years up to 65 lbs. These cars are available at retail stores such as Toys-R-Us. The frame is basically comprised of plastic and has a seat, steering wheel, and four rotating wheels, resembling a normal automobile. The cars either have a push button or foot pedal that when activated propels the car forward at 2-3.5 mph [4].

Past GBG projects have taken these power wheels cars and retrofitted them to the standards of the child whom they are providing it for. As seen in the picture in fig. (1) typically plastic railing, made of PVC wrapped in a pool noodle, and a harness or torso supporting seat is added to the car to offer more support and safety for the child. In many cases a big red push go-button is also attached to the steering wheel in order to make the action of putting the car in motion, more accessible and easy for kids to to operate themselves. These additions are the base retrofits that make these cars adaptable for children with less mobility abilities.



*Figure 2: System Structure*

### **1.3.2 Original System Operation**

The most important modifications to the power wheels cars is adding a go-button that moves the car and creating a steering system that are both operable and safe for the child. As stated before typically a big red button is attached to the steering wheel, but there are other cases in which the go-button has been strategically placed so that the child must do a small physical activity in order to push the go-button; a couple examples of this are: in one case a GBG car was modified so that the go-button was located under the feet of the child riding the car so that they would have to stand up in order to push the button, in another case a car was modified so that the go-button was located behind the head of a child, who had trouble keeping her head up, so that she would have to push her head back in order to push the button, these relative locations were chosen to help the children develop stronger muscles that they normally don't exercise [5]. Changing/adding a go-button can be challenging for a parent or person that has no prior experience with rewiring, so in many cases a project team will either, do the rewiring or create step-by-step instructions that one is easily able to follow in order to rewire the go-button themselves.

Another important aspect is the steering system of the ride-on car. In the cases where a child has some mobility with their arms and hands, the project designers may choose to keep the original steering wheel as to encourage more physical exercise, such as hand eye coordination and gripping. In the case that a child doesn't has the full mobility to use the original steering wheel, some projects have modified the wheel adding on mobility assisted driving devices, such as a quad fork spinner [6], or created a new steering system all together. These modifications have a lot of importance, because they not only allow the child to have physical control of the wheels and direction of the car, but this also gives a child the independence to move freely wherever they would like to go.

### **1.3.3 Original System Performance**

A common store bought 6V electric vehicle runs at 18000 RPM. Usually operated by a steering wheel and pedals, with a few exceptions: motorbikes, 4x4, and etc. Runs at a instant speed of 2 mph and can reach a top speed of 3.5 mph. These vehicles have a typical age limit of 18 months to 3 years old. An 18 month

old child has an average weight of 22.65 lbs. While a 3 year old child has an average weight of 26.5 lbs [7]. It is safe to assume that these vehicles operate within those range. With some vehicles that are rated for ages as up to 5 years old, roughly 75 lbs.

The vehicles are modified to fit the needs of the user. Usually using PVC pipes and pool noodles for added support. They are easily assembled and lightweight, with a few special cases. The overall performance, as seen in appendix A: table 1, of the current GBG vehicles are calculated by comparing these vehicles to seven criteria: cost, safety, transportable, lifetime, material accessibility, assembly, and control system.

The criteria are rated from a scale of 5. Each criteria is separated into a grading system, for a poor system the ratings are limited to (0 to 2.5) and for a system that are above decent the rating are (3 to 5). More information on the grading breakdown are provided in appendix A: table 1 . The overall performance of the system is decent but is in need of improvements.

### ***1.3.4 Original System Deficiencies***

There are many deficiencies that need improvements in GBG vehicles. They are limited from three to five years and there are few vehicles outside US that fit children as young as two to three years old. As a results, there are commercially available vehicles for children under two years old [8]. In addition, they can hold a weight of 75 lb maximum per child. For current vehicles, childrens are not able to touch and play with grass since they are stuck in the vehicle with PVC pipes surrounding them. Figure 5 represented a vehicle with a harness attached to pipes in the roof. This system will limit children's activities to be indoor and they will not be able to go outside and play. Another deficiency in GBG cars is the speed that these cars go when children press the pedal of the car or hit the button that makes the car moves. Theses cars go with 2 m/hr as soon it moves which makes the child snap back to his/her seat. This action would make the child scared and he/she might panic and start crying and start fearing this car. in addition, there is the weight limit that these cars can hold. Most of GBG cars run with 6v motor and this motor would make the car incapable of taking high weights. We were presented to the idea of using a 12v motor in our car by our client which will be the solution to this problem if we were able to replace the 6v motor with a 12v motor. In fact, there is an issue with the wires when considering to modify a larger ride-on car. The "Big Red" model adjusted switch utilizes wires that are too little in diameter to be utilized with a bigger 12v ride-on car. It is vital that the wire measurement of any new switch coordinates the wire diameter across the current wire inside the ride-on-auto. If this important issue was not solved, the wires would have a possibility of catching fire.





*Figure 3: Example of System Deficiency*

## **2 REQUIREMENTS**

Project requirements help to know what areas are important to focus on and how a project might be evaluated. This section has three parts: 1) customer requirements and weightings, 2) engineering requirements, absolute technical importance (ATI), relative technical importance (RTI), and targets/tolerances, 3) testing plans and design links. Below are each part broken down and explained, as well as a house of quality which gives an overview and relationship between each part.

### **2.1 Customer Requirements (CRs)**

After meeting with the client and discussing the project, customer requirements were developed to highlight what is most important to the client. These customer requirements, as well as their weightings as to how important customer requirements are displayed in table 1 and explained:

**Table1: Customer Requirements and Weightings**

<b>Customer Requirements</b>	<b>Weighting</b>	
<b>Cost</b>	4	11.59%
<b>Safety</b>	5	14.49%
<b>Quality</b>	4.5	13.04%
<b>Transportable</b>	3.5	10.14%
<b>Unique Solution</b>	4	11.59%
<b>Longlife Time</b>	3	8.70%
<b>Material accessibility</b>	4	11.59%
<b>Easy to assemble</b>	3.5	10.14%
<b>Control System</b>	3	8.70%
<b>Total:</b>	34.5	100.00%

**Cost** - Must be affordable for parents to purchase all materials, preferably much cheaper than a motorized wheelchair ranging from \$1,500-\$4,000 [9].

**Safety** - The product must be safe to use for the user and the guardian present. The team agreed that this will be a top priority and gave it the highest scale rating of 5.

**Quality** - The electronics and steering system of the product, along with the materials themselves need to be reliable, meaning they will last and work properly, and made so that they are safe for children.

**Transportable** - The product should be lightweight and have a compact design, that way the parent can be able to pick up the product and have it fit into the trunk of their car.

**Unique Solution** - The product should be innovative, as well as adaptable to children with a variety of disabilities, hopefully adding an aspect of being aesthetically appealing for the kid as well.

**Longlife** - The lifetime of the product, as explained from the information given to the team, fit a certain trend. Children that are given these vehicles tend to only benefit them from the ages of 2 to 5. Thus the lifespan of the product is not a big concern in the design process, but should still work and last for that time frame.

**Material accessibility** - The product must be accessible for all parents, meaning the team must find materials that are easy to find in stores located nearby and common to all parents, as they may be purchasing everything separately.

**Easy to Assemble** - Team should provide tips and instructions on how to build the final product as parents may be assembling the car themselves. The car shouldn't take a long time to complete assembling it and be so advanced that a person with no prior experience is unable to do it.

**Control System** - There are two components to this C.R.

1. The client's requested for a product that has a remote control capability. So that control of the product can be shared and thus increasing the safety of the user. As most of the children that use the product are young. For example: the child might not fully know the dangers of an open road or the potential dangers of untamed animals.
2. The control system should be adaptable or accepting to children with limited to no mobility with their arms and hands.

## 2.2 Engineering Requirements (ERs)

Engineering requirements is basically taking the customer needs and modify them. Every project's engineering requirements will differ from those of anyone else because ours is applied to a specific problem statement. These engineering requirements will specify how our design will meet our customer requirements. After meeting with our client, we were able of generating our project engineering requirements. Below, is a table with the engineering requirements generated.

*Table 2: Engineering Requirements with Targets and Tolerances*

Engineering Requirements	Target	Tolerance
<b>Material Cost</b>	\$350	< \$400
<b># of Securements</b>	2	> 4
<b># of Supports</b>	2	> 4
<b>Weight of Car</b>	60 lbs.	< 100 lbs.
<b>Material Access</b>	Local Stores	Shipping < 3 weeks
<b>Assembly Time</b>	2.5 hrs.	< 4 hrs.
<b>Significant Material Lifetime</b>	3 years	> 5 years
<b>Adaptability</b>	4	> 4
<b>Adjustable Speed</b>	Starting speed of 1 mph	< 2 mph
<b>Unique Solution</b>	Unique from past GBG solutions	Unique

The engineering requirements for this project were constructed based on the customer requirements seen in table 1. The engineering requirements were approved by the client, Sarah Oman.

**Material Cost** - The client had specifically asked to create a product that would be affordable for a typical family. The target cost is \$350 for all materials required and the car itself, with a tolerance of < \$400.

**# of Securements** - Securements refers to the number of seat belts or harnesses on the car for the child's safety. The target is 2 separate ways securing the child into the car, with a tolerance of  $> 4$  depending on the child's needs.

**# of Supports** - Supports refers to the number of safety equipment on the car that will help the child's posture. As well as equipment that offer comfortability. The target is having 2 support equipments, pvc and pool noodles, to help support the child while operating the vehicle, with a tolerance of  $> 4$  depending on the child's needs.

**Weight of Car** - The entire car will all and any modifications must be easily picked up by the child's guardian. The target weight is 60 lbs. which is a reasonable weight for the project's application, with a tolerance of  $< 100$  lbs.

**Material Access** - The materials needed to build the product must be easily obtained through local stores or online shops with a tolerance of 3 week shipping.

**Assembly Time** - The time required to modify the car, as well as build the necessary attachments in one sitting, should only take 2.5 hours, with a tolerance of  $< 4$  hours.

**Significant Material Lifetime** - The significant material for the project will be the main car itself. The car must have a lifetime of 3 years with a tolerance of  $> 5$  years.

**Adaptability** - The car should be adaptable for different users as the children who will be using the product have varying needs. This will be solved by having different options of how the child can be secured into the car. As well as having different options for how the child can operate the car. The target is 4 different ways, with a tolerance of  $> 4$ .

**Adjustable Speed** - Adjustable speed for the vehicle is for the CS team that is working on the project. For the purposes of this project adjustable speed will be a design option.

**Unique Solution** - The client has asked to create a product that is unique. This requirement cannot be quantified and therefore will be fulfilled by designing a solution that does not repeat previous GBG solutions.

### **2.3 Testing Procedures (TP's)**

Testing procedure is a standardized and documented process for performing an experiment. This step is important towards finding the best approach to maximize engineering requirements efficiency. After generating customer requirements, our team developed engineering requirements based on these customer requirements. After getting the client approval for the engineering requirements, we must set how we are going to test them in order to meet project outcomes. For our engineering requirements, our team generated ten engineering requirements. They contained all the necessary features that can reveal a GBG car that meets our client requirements. Testing procedures for all the engineering requirements are listed below.

**1 Selection of Materials:** The testing procedure for material selection would examine how accessible each material is as well, what is its lifetime, its cost and total weight of the car. Each component will be evaluated as to its accessibility to parents in Arizona, as to where each component is available in retail stores and if ordered online, that it will ship to everyone as well. If ordered online the time to ship will also be evaluated with a target time of less than three weeks. The target lifetime of the main body is three years and since we cannot test this lifetime. The PVC pipes and pool noodles are easily replaced, therefore their lifetime will not be included in the testing. As for the button and the parts that go along with it's

operation, their specifications will also serve as the testing procedure. As there is not enough time to properly place the button under constant usage and wait for it to fail. The cost would be by looking for different options for the material needed. For example, looking for different types of 6v motors and compare their efficiency and their cost and then decide what our team should select. The weight of car will be tested by weighing the car. The team is targeting to reach a weight of 60lb, <100lb, so that it will be easy to transport.

**2 Reliability of Securements and Supports:** The number of securements will be tested by visually inspecting all aspects of the car and evaluating which components count as a securement. Each securing component will be tallied up to get a target of three securements and with a minimum of two. The number of supports will be tested by checking every supports in the car which will be PVC pipes and seat belt (5 point or standard seat belt). Each support will be corresponded to a target of three supports and minimum of two, (3,>2).

**3 Control Reliability:** The unique solution will be tested by trying to run the car using two buttons. These two buttons will be added under the seat for children who can not stretch their arms. Each button will be linked to a motor, so the car would have two motors. Each button will have different direction to move the car when the kid press it. For example, the button on the right would move the car to the right side. The speed of the product will be tested by running the two 6V motors of the car. They will be run on a measured track and will be timed for 1 minute. The car distance will then be measured and converted into a mph reading. Adaptability will be tested by observing how the user would accept the solution. It depends on how the user is comfortable using the car. Also, The car should be adaptable for different users as the children who will be using the product have varying needs. This will be solved by having different options of how the child can be secured into the car. As well as having different options for how the child can operate the car. Assembly time will be tested by putting together the solution and seeing how long it would take. We must be able to put it together within the time proposed by our client.

## **2.4 Design Links (DL's)**

Design links is describing each engineering requirements and how our proposed design meets these engineering requirements. This step will allow our team to have full knowledge on how our proposed design will look like. In addition, this process featured all the necessary parts needed for our proposed design. Below are the engineering requirements described and how they meet the proposed design.

**1 Full Design:** The client had specifically asked to create a product that would be affordable for a typical family. The target cost is \$350 for all materials required and the car itself. The final version of the design proposed must meet the amount above after we put together all the components. All components will be included in the design link and related to engineering requirements, as all have affect the total weight. Therefore, it will be evaluated. Car weight must not exceed 100 lb in order for the parents to lift and carry the car easily. In addition, having heavy components will add more loads to the motors and it might affect their efficiency. All components in the final design are related to this engineering requirement and therefore will be evaluated. All materials used in the final design must be available for the parents. For example, parents should go to the local store and be able to find the material easily. In case of shipping the materials, shipping must not exceed three weeks to deliver the materials. The button and the main body of the vehicles will be the governing designs to satisfy the significant material lifetime of 3 years, with a 5

year tolerance. By targeting a lifetime of three years, we will be able to have parents purchasing the car once with no need to spend more money on purchasing it again. The time required to modify the car, as well as build the necessary attachments in one sitting. Our team targeting to make the assembly time is 2.5 hours. Furthermore, the materials must not be complicated to put together.

**2 Harness and Railing:** The safety of the door/frame itself, the seat belt (5 point or standard), and the railing wrapped in a protective material are possible components which could be evaluated on the final design. The proposed design will assure the safety of the child because safety is considered to be the first priority for the design proposed.

**3 Structural Supports:** The PVC pipes and the seat belt could be evaluated on the final design, also the structure of the seat and how it supports the the kid's back. In addition, if the seat is long enough, it can support the kid's neck. The PVC pipes must not block the view of the rider and they must secure the child.

**4 Two Buttons:** The idea of using two buttons would meet our customer requirement and client requirement because this idea has not been used before. This solution would help children who can not use their hand to move the steering wheel. In addition, it would not cost too much because we only need to link those buttons to the motors. The two motors will be the governing design for this requirement. A program that controls the speed of the two motors would also be a governing design to satisfy this requirement. Our team targeting to have four different options to meet client request where the car can be used by different needs. For example, the car would be adaptable for children who cannot use their hands and their legs. Moreover, the seating system will be adaptable for children who cannot move their arms/legs and who cannot set normally on their back.

## ***2.5 House of Quality***

The House of Quality (Appendix A: Table 3) was constructed based on the customer requirements (Table 1) and engineering requirements (Table 2). The engineering requirements were compared to the customer requirements and were given a scaling of 1 to 5. A scaling of 1 means that there were little to no correlation while a scaling of 5 means that there was a direct correlation between the two requirements. From this scaling the absolute technical importance, ATI, was calculated (Table 3). And from the ATI the relative technical importance, RTI, was constructed (Table 3). The RTI had a 1 to 10 scaling, 1 being the least important and 10 being the most important. House of quality helped the team in determining how our product meet our customer requirements. Also, it was an effective method of linking customer requirements to engineering requirements. By creating house of quality, our team was able to change/alter components, eliminate poor function of the design, and add more functionality to the design. Table 3 has concluded that our main focus shall be on the total cost and the lifetime of our final product. Second in importance was the safety of the child. The child must feel relatively safe and comfortable when operating our product. All other ER's have been concluded to be relatively important but are not the main focus for our project.

*Table 3: ATI and RTI*

<b>Engineering Requirements</b>	<b>ATI</b>	<b>RTI</b>
<b>Material Cost</b>	80.5	10
<b># of Securements</b>	44	8
<b># of Supports</b>	44	8
<b>Weight of Car</b>	32.5	6
<b>Material Access</b>	28	4
<b>Assembly Time</b>	17.5	3
<b>Significant Material Lifetime</b>	65	9
<b>Adaptability</b>	15	2
<b>Adjustable Speed</b>	44.5	5
<b>Unique Solution</b>	35	7

### **3 EXISTING DESIGNS**

In this part, our team gathered information that was related to our project. The goal was to spend a significant amount of time on locating information that helped us in understanding how previous design work. In addition, the team focused on the problems that previous designs had. By evaluating these problems, the team had avoided running into the same mistakes. This section provided more details on successes associated with existing designs, cost, and market needs.

#### **3.1 Design Research**

GBG have created many user fitted assistive vehicles for children. Cole Galloway with the help of GBG has created projects that have helped two particular children [10]. Xander (fig. 4) is one of those children. Xander is afflicted with low muscle tones in his legs. The Go Baby Go project fitted a vehicle to have a start button operated by the user's weight. This allows Xander to exercise his leg muscles helping him with his physical therapy, by allowing Xander to stand while operating his vehicle. Sarah (fig. 5) also has an individually fitted vehicle. Her vehicle differs in that her start button was located at the head rest. To allow her to exercise her neck muscle as she had never had a reason to. This particular GBG project implemented these user friendly design to the final product.



*Figure 4: Xander*



*Figure 5: Sarah*

In order to develop self-sufficiency, self-reliability, and Do-It-Yourself competencies, it was necessary that the design of the cars should not only be attractive but also easy-to-use. Keeping in view these two requirements, the search of the websites led the team to look for existing projects. It led us to see into and review at length the current availability of toy cars prepared for children restrained from movement through the project called DIYability. This project has been sponsored by the University of Delaware and is affordable. The cars prepared have two important objectives. One, primarily they are meant to ease the movement restrictions of the children due to their disabilities. Two, they are also meant to remove the social stigmas attached with disabilities. It is unfortunate that many children become a victim of social withdrawal and face additional problems in socialization and social integration due to their physical disabilities. These cars ease their movement and enable them live on themselves as much as they can.

There were, however, a number of things that our team found in need of improvement. In these cars, there are still restrictions and difficulties in terms of movement and children may still face problems in operating these instruments of their vital interest. Our project, therefore, was to review the positions of



facilities such as switching placement, comfortable positioning and seating, operating easiness, and so on. We also wanted to add ease for parents and siblings in dealing with the arousal of any possible problem. In this context, we were particularly concerned about the safety issues. The wiring of existing cars are open and can be touched from below. It can be hazardous and we should be particularly mindful of this fact because these toy cars are to be operated by children with physical disabilities. In this context, the team wanted to develop user-friendly but secure manual to be delivered to the users, their parents, and siblings in order to be informed of the technical details of operations. The team also wanted to improve the body design and overall appearance of the toy car in order to delight the children and facilitate them in developing skills and feelings to integrate into society.

## **3.2 *System Level***

System level was an important step towards our project because it provided us with an overview of the project. It helped us to identify and establish how components of existing designs worked and how to identify the system processes and functional components. In addition, it assisted us to define the components that were needed for our project. In the section, the team evaluated existing designs that were related to our project. After that, the team addressed requirements relevant towards the project. The goal of this section was to specify the overall purpose of this project. After analyzing each of the three designs below, our team focused on the mechanical components, power, and electronic components. For mechanical components, our team focused on how these systems fit together. For power, the team was focused on when the car would start to move and when it would stop. For example, when pressing a joystick forward, the car would move forward and so on. For electronic components, the team team focused on power of the car because most Go Baby Go cars only use six volts motor. The client of the project asked the team to try to implement a 12-volt motor because a 12-volt motor would allow the car to take higher weights. In the next section, the team moved into the subsystem level, which would be more in depth with the subsystems.

### **3.2.1 *Existing Design #1: The Ultimate Toy Hack***

In this design, Go Baby Go team modified the Lighting McQueen Disney character car in which to accept a standard mono plug capability/access switch. In addition, the car was adapted with a PVC pipe support system wrapped with swimming noodle for cushion. The noodle acted as a way to hide the switch wires. Furthermore, the noodle served as a safety in case an arm or head might be into contact with the PVC system. This design would help the team to develop the safety of our design because safety is the most important customer requirement and it has been rated five out of five when weighting each customer requirement. This design would helped us in dealing with the car's wires because the wires must be hidden so that the child would not be harmed [12].



*Figure 6: The Ultimate Toy Hack [12]*

### **3.2.2 Existing Design #2: Electric Car Jeep**

In this design, a light switch was adapted to replace the steering wheel in which the light switch would handle current that supplied the electric car motor. This light switch would help children who unable to use the foot pedal switch. Instead, they would use their hand to control the car movement through the light switch in which it would be available in front of their hands. This design helped our team to come up with ideas to replace the steering wheel. The idea of using a light switch will make children more capable of controlling the car. In addition, this design addressed how we could modify the car's speed in different speeds because our client had told us about some cars that go two miles in speed when children move the steering wheel which make them panic and afraid of the car [12].



*Figure 7: Electric Car Jeep [12]*

### **3.2.3 Existing Design #3: Baby Mobility Robot**

In this design, the original Go Baby Go team created a mobility robot car. This robotic car consisted of a joystick and infrared sonar sensors with obstacle-avoidance software. Then, they developed this robot and put more functions into it. They made the robot light in weight. In addition, they added a convertible power-chair/walker. This design improved the way our team think about stability of the car because

children were able to control the robot and make it move in the direction they wanted. This design gave the team an idea about how to reduce the weight of the car because the team wanted the car to be easy to carry in order to make the transportation of the vehicle effortless [13].



*Figure 8: Baby Mobility Robot [13]*

### **3.3 Subsystem Level**

There were three subsystems that were examined and researched to better understand each individual component and review some possible design routes the team may want to pursue. These subsystems included modifying or creating a new steering system, governing the acceleration of the vehicle, and the accessibility of the vehicle. Each one of these components had a unique purpose and with a well developed design that focused in each area, the overall experience for the kid would be improved.

#### **3.3.1 Subsystem #1: Modifying or Creating a New Steering System**

In the past, many steering systems of a GBG ride-on car have kept the original steering wheel, which may work for some children with arm/hand mobility, but it may not work for many children without those abilities. This subsystem explored the possibilities of other options for steering/control mobility from a mechanical standpoint.

##### **3.3.1.1 Existing Design #1: Mobility Assisted Driving Devices**

Many mobility assisted driving devices already exist for the purpose of assisting adults with a physical handicap to be able to drive a vehicle safely. Some of these designs have the potential to be modified to a child size and attached to the ride-on cars steering wheel to assist children with limited mobility. Three potential devices are a quad fork spinner, tri-pin, and a palm spinner [6]. All of these devices operate with the prerequisite that the child has mobility of their arms, but less mobility with their hands. They all attach to the steering wheel and are free spinning, meaning they are able to spin as the wheel turns and continually stay in the appropriate position for the user, but they don't require the child to have to grip anything in order to steer, simply just place their arm or hand in the device.



*Figure 9: example of quad fork spinner [6]*

### **3.3.1.2 Existing Design #2: Atari Joystick**

An atari joystick is a device that was created for playing simple video games on the t.v. (fig. 10). It has a basic mechanical design and electrical system that potentially could be modified and mounted on a ride-on car in place of a steering wheel. The system works by a stick connected to a circuit board that closes the circuit to complete the connection between two wires, when it is pushed in a certain direction [14]. The joystick connected with a platform such as an Arduino could be programmed and used to combine the operations of moving the car, replacing a foot pedal or go-button, and the steering system. If connected correctly, the child would simply have to push the joystick in the direction in which they would like to go and the car would move in that direction. It could also add an option of having a reverse gear as well, something that typically is not included in a GBG project design, which would be activated by pulling back on the joystick.



*Figure 10: Atari joystick [14]*

### 3.3.1.3 Existing Design #3: Learning by Leaning

In some cases, a child may have no real mobility of their arms and hands, this would make steering the car a real problem with the basic design ideas used in past projects. This brings up the idea of allowing the child to steer the car using the motion of their torso by leaning from side to side and thus turning the car in the direction in which they lean. A tricycle that was recently developed called the Dreisch leaning tricycle, allows a child to lean while turning to develop the muscle memory and skills to ride a bicycle. The tricycle “addresses the counterintuitive physics of muscle memory by shifting the steering to the rear axle via a hinge and a pivoting swing-arm that runs the length of the frame. The result is a 'natural' turning mechanism [15].” This mechanical system could be used in the design of a GBG car, where the hinge and pivoting swing-arm would allow a child to lean side to side, while still offering support so that they are able to easily return to a normal sitting position. This mechanism could be attached to a cable system or possibly switches on both sides, so that when the child leans to the side it activates the control system and turns the car in that same direction.

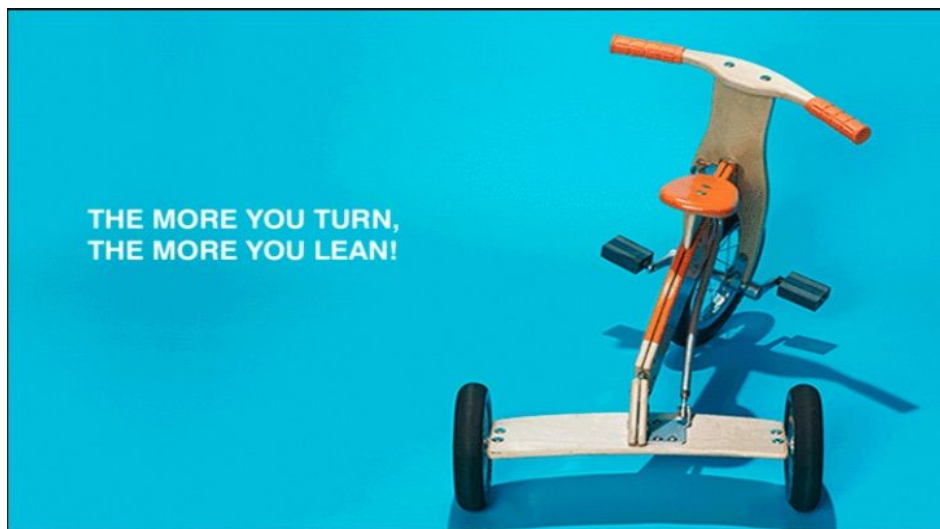

*Figure 11: Dreisch Tricycle [15]*

### 3.3.2 Subsystem #2: Governing the acceleration

Governing the acceleration is one of the most important aspects of GBG cars because it reflects on the overall performance of the car. If the user was able of controlling the acceleration, he would be able of improving the motion control of the car. There are some possible factors that can affect the acceleration performance which are pedal misapplication and unresponsive (entrapped) pedals. In GBG cars, the car goes with full 2 m/hr when pushing the pedal. This issue could be solved by suggesting existing designs that present the idea of controlling the acceleration.

#### 3.3.2.1 Existing Design #1: A shift selector

This design is for a children's car and it is almost similar to the designs that are used for GBG cars. This design uses a shift selector, which allows the driver to select forward or reverse direction. This feature is exactly what we are trying to implement into our design because it will help the child to control the car easily. In addition, it will prevent the car of taking sharp path, which might cause the car to flip [16].

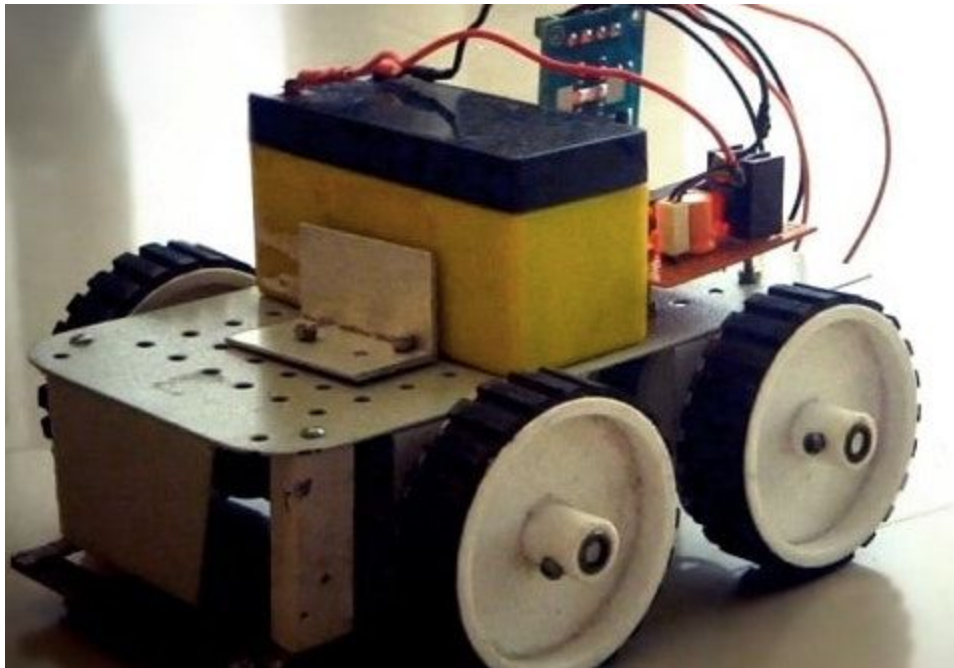



***Figure 12: Ferrari F12 Berlinetta 6V [16]***

### ***3.3.2.2 Existing Design #2: DIY Remote Control Car***

This design is useful to control acceleration on GBG cars. It uses a remote control in order to govern the acceleration. It transmits control signals through radio frequency and receives it through a receiver module in the car. This remote control will have two switches to power each motor of the car. The team could implement this idea into our project by having the created remote control in front of the child, so he/she would be able controlling the car by just pressing buttons on this remote controller [17].



***Figure 13: DIY Remote Control Car [17]***

### ***3.3.2.3 Existing Design #3: Different Tires and Reducing the Weight***

This website gives some great ideas about how to govern acceleration on racing cars. It presents the idea of using different tires for the racecar. It advises that using a larger diameter tires could help in controlling the car and prevent it from slipping. The second feature is reducing the weight of the car because reducing the car weight will make it easier to control and easier to change directions. The team

would take these ideas in consideration because these features will help us to have full control of the car acceleration by replacing heavy parts with light carbon, graphite or aluminum parts [18].



*Figure 14: Different Tires [18]*

### **3.3.3 Subsystem #3: Accessibility**

GBG cars makers care about how to make these cars accessible for children with disability. They want the process of using these cars to be simple and fast. In order to provide accessibility to the users, engineers must have full knowledge of the condition that they are dealing with. For example, the weight of the baby and what parts of his/her body they are able to move and which they are not able to use. By knowing this information, the solution would be found to fit the condition of the disabled child.

#### **3.3.3.1 Existing Design #1: Hand Controls**

This design is built for those who cannot use their legs for driving cars. It has the idea of replacing the pedal with a joystick that is built on the steering wheel so that they can control the car easily. This idea would help our team in providing more accessibility to the users depending on the condition. For example, if a child cannot move his/her legs, he/she will be able to have full control over the car by using his/her hands [19].



*Figure 15: Mechanical Hand Control [19]*

### 3.3.3.2 Existing Design #2: Seating Solutions

This design presents the idea of having the car seat moves and rotates in order for the user to enter and exit the car easily and without the need of the help of someone. However, the team could implement this idea into our project by having the car seat rotates when the child wants to exist the car. The opposite works as well if the child wants to ride the car, the seat would go either down or out the car so that he enters the car easily. The team want to make the car seat stable while driving the car by making sure that this feature will not affect the stability of the seat [20].



*Figure 16: Seating Solution [20]*

### 3.3.3.3 Existing Design #3: Scoot

Scoot is a famous design that helps children with different disabilities to explore their surroundings. There are three different designs of the scoot and each one is represented to a specific condition. One of these design where the child lays on his stomach and have control where to go. The team could benefit from this design by considering this kind of disability, so if the child is not able of sitting, he/she is still able to control the car and explore the surroundings [21].



*Figure 17: Scoot [21]*



## 4 DESIGNS CONSIDERED

Once data and information had been collected on past systems and on benchmarking past designs, the team took the time to do some concept generation and get some ideas down on paper, as well as create a functional model. Two approaches were used when conducting concept generation, the first method was creating morph matrices and the second method was a C-sketch. The team took 20 minutes for each team member to create their own morph matrix, which broke down the overall vehicle into different components: steering system, security system, movement of the vehicle, governing the speed, how the vehicle is activated (go button), and accessibility for the kid to interact with their surrounding environment. For each individual component different options/ideas were generated for each in the matrix. Once the 20 minutes had finished the team took another 15 minutes to create multiple vehicles mix matching the different options. The second method, C-sketch, began with all team members drawing a base design concept with small descriptions of components. The drawings were then passed around from team member to team member as each person took the time to understand and then add or alter the original design to make it more creative or improve upon the design. This second method resulted in five more in depth designs. These two methods of concept generation resulted in 21 designs, of which 12 were actually plausible. The top ten designs are listed below:

### 4.1 Functional Model

The functional model broke down the project based on what was done, not how. This makes the system into something simple and conceivable, allowing the team to focus on different aspects of the car. This process also helped in the concept generation using the morph matrix method. By creating the functional model the team was able to see the simple functions that make up our project and helped with deciding which areas the team wanted to focus its efforts; these areas are the safety of the vehicle, specifically the seat belt securement system and railing system that protects and supports, and the accessibility of the vehicle, how a kid is able to operate the vehicle and also interact outside of the vehicle.

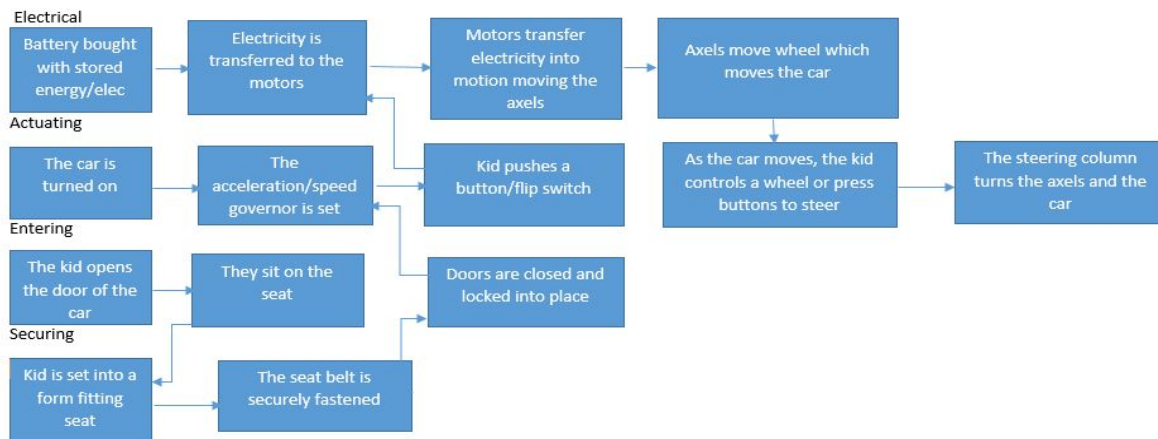

Figure 18: Functional Model

### 4.2 Design #1: Belly Car

This design reorients the kid so they would be laying down on their stomach, at an upward angle, and be supported by a unique seat that allows them to be comfortable. The participant controlling the vehicle would use either two joysticks (Figure 19), a steering wheel with their extended arms, or even sensors could be added at the points of contact with their shoulders allowing them to push down one side or the

other and turn the vehicle in that same direction. In this design the acceleration and different speeds are ungoverned. The shape of the vehicle would be smaller and lower in the front to allow for more visibility. The whole point of this design is to allow a kid to lean out of the vehicle easily and touch/interact with their surroundings. They would be supported by a harness that allows for movement but keeps them secure and safe. Doors could also be added to for more safety.

**Advantages:** Unique design and control system, allows for more accessibility to surrounding environment.

**Disadvantages:** Could potentially be unsafe, strays far from the powerwheels design and could be difficult to assemble, as well as material accessibility may be difficult.

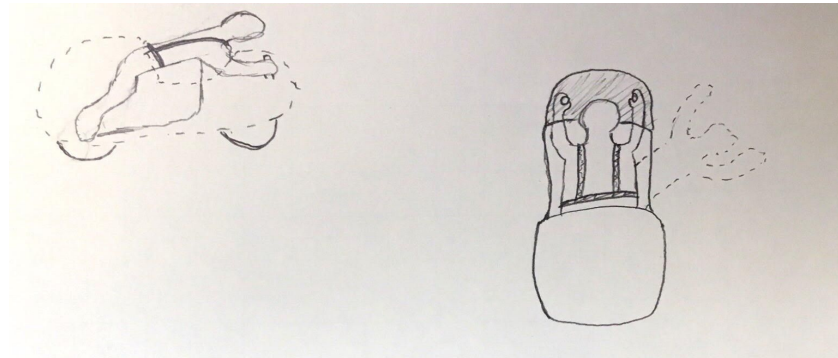

*Figure 19: Belly Car*

### **4.3 Design #2: Laying Down Car**

This design is based off of a soap box racer design, this concept allows the kid to lay down on their back at a comfortable position, while bringing them closer to the ground and closer to their surrounding environment. The shell of the vehicle is a simple plastic design, with limited siding near the kids torso and arms. The control system is a normal steering wheel and the acceleration or speed of the car is ungoverned. However, the advantage of this design is that as it brings the kid closer to their surrounding environment and has very open sides, this allows them to simply reach out and touch/interact with things around them.

**Advantages:** Accessibility and simple yet unique design

**Disadvantages:** Could potentially be unsafe and would require a build from the ground up, making assembly difficult

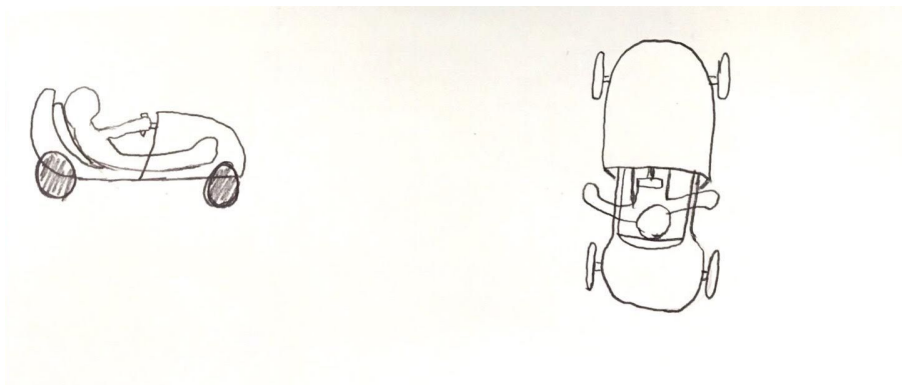

*Figure 20: Laying Down Car*

#### 4.4 Design #3: Rounded Base Car

A “rounded” car that has a weight activated “go” and an off toggle button for when the kid needs to stop. The car will move at a slow pace starting from 0.5 mph and reaching a maximum speed of 2 mph. The vehicle is operated using a standard steering wheel. The seat uses a supportive seat formed to the kid, with a seat belt. The kid is also secured using pvc pipes and pool noodles with an extra seat belt around the pvc supports. This design allows for more open space for the child to touch their surroundings.

**Advantages:** Accessibility and offers a simple solution to the restrictions of a standard shaped car.

**Disadvantages:** Would need to make or create the base, making the assembly difficult.



Figure 21: Rounded Base Car

#### 4.5 Design #4: Two Button Car

Armrests would be incorporated into this design, where two buttons would be located; these two buttons would control the steering of the car as well as activate the car to go forward. When the kid pushes one button, for example the one on the right, the car will respond and turn in that same direction, if both are pushed together then the car would move in a forward direction. The purpose of this control system is to allow the car to be more adaptable to kids who may not have a lot of mobility with their arms and/or hands. This car as it stands has no acceleration or speed governor. This design also includes two doors on either side in order to enter the car, but also to be easily opened so that the kid can reach out and interact with their surrounding environment.

**Advantages:** Adaptable control system for a variety of kids, comfortable environment, and accessible

**Disadvantages:** Costly design, involves more electrical components than most making it difficult to assemble correctly.

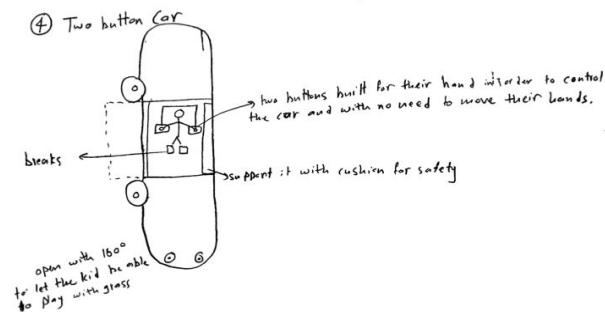

Figure 22: Two Button Car

## 4.6 Design #5: Spring Car

This design is solution #3 from the Morph Matrix that the team performed. This solution incorporates four options. It combines adding wheels that are far from the body of the car, a circle button to control the car, a door that makes the car stop whenever it opens, so the kid does not get hurt, springs that will be put under the seat and on the stick that connecting the wheels with the body of the car.

**Advantages:** This car will prevent the driver from feeling the bumps because the body is far away from the ground. Also, the springs under the seat would make it easier for the driver to lean on the side and touch the surroundings.

**Disadvantages:** Springs sometimes are not comfortable because they move as long the car is moving.

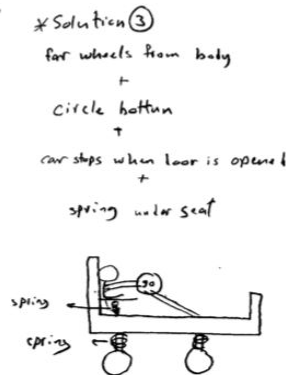

Figure 23: Spring Car

## 4.7 Design #6: Drag Car

This is a C-Sketch model where all team members added their ideas on the original one. The original idea was a design that is for children who cannot sit on their back and they have to lie on their stomach to move around. The design has two joysticks that will allow more control on the car. The Back tire is bigger than the front tire to allow more view of the surroundings. Team added flames on the car body for coolness.

**Advantages:** This design will be efficient for kids who cannot lie on their back since almost all GBG cars are built with a seat.

**Disadvantages:** This design will be cost effective because of the features added. Also, a cushion must be added as well as PVC pipes and noodles which would cost more.

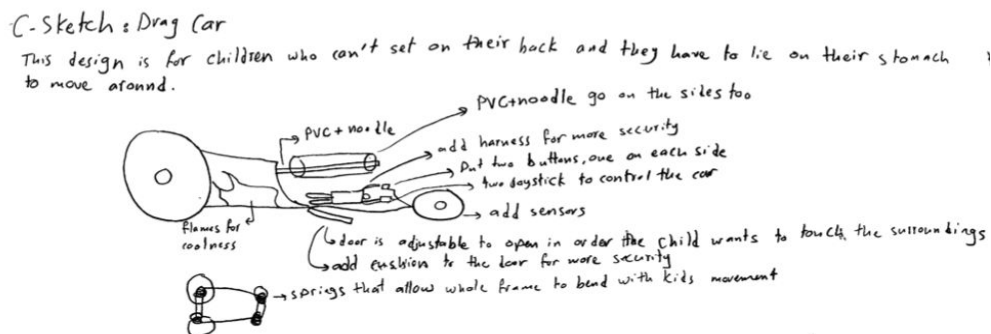

Figure 24: Drag Car

## 4.8 Design #7: Snail car

This is a Bio-Inspired design and it uses some snail features. A snail hides inside his shell whenever he sees danger. The shell keeps him safe and secured. The team would use this idea to create a car that has a glass shell to keep the kid secured from outside objects such as the rain and the sun. In addition, another idea to consider is the features could be used to add an umbrella to the car and this umbrella could be taken off when the kid finished playing with the car, so the car can fit in the back of parents' car.

**Advantages:** An umbrella would cost little to be added to the car. Protecting the kid from outside objects.

**Disadvantages:** If the glass shell added, we must have a way in order for air to enter the car. Also, the glass shell would cost too much and it must be shaped to fit the car. In addition, glass is not a good option because it breaks easily.

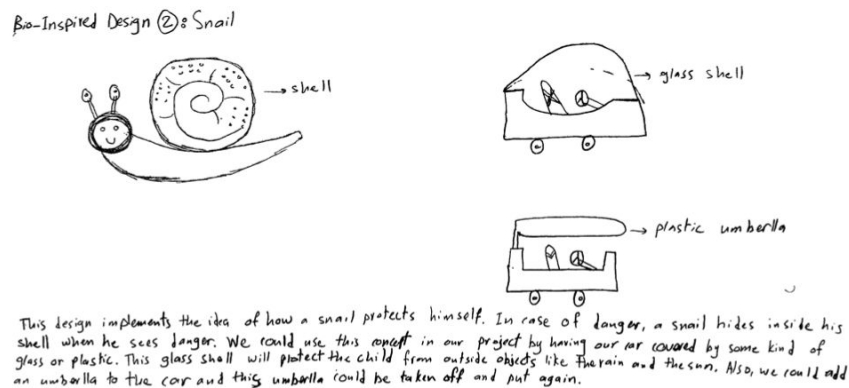

Figure 25: Snail Car

## 4.9 Design #8: Grasshopper Car

Grasshopper has big legs in its back and small ones on its forehead to allow it to see better. This feature would help us in making the rear tires for the car bigger than the front tires to give the kid better view of the road.

**Advantages:** Better view and more control of the car. Big tires allow for more safety in case of the rain.

**Disadvantages:** Big tires might not fit into the body of the car since we are limited to the car that we are buying. Big tires would require more power to have them work normally.

Bio-inspired: Grasshopper Car:

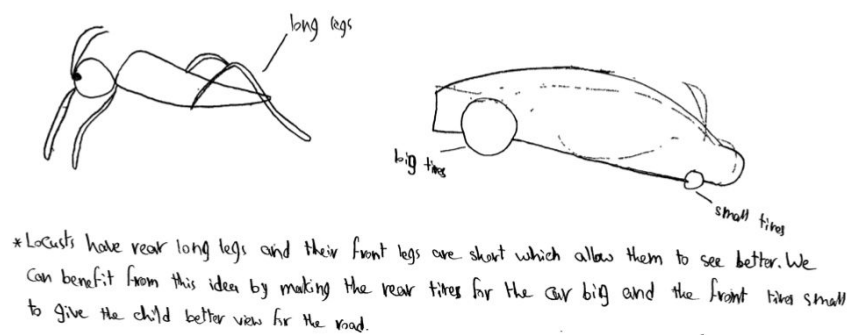

Figure 26: Grasshopper Car

#### 4.10 Design #9: Ostrich Car

Ostrich has long legs that make its body far from the ground which help it to avoid bumps that could affect its movement. The team can make the car body far from the ground, so the child will not feel any bumps. Furthermore, the team can add springs to the steering wheels in order to avoid the effects of the road.

**Advantages:** Not feeling the bumps and more security for the car.

**Disadvantages:** Having the car far from the ground will not allow the kid to touch the surroundings since this issue was brought from our client.

Bio-inspired: Ostrich Car.

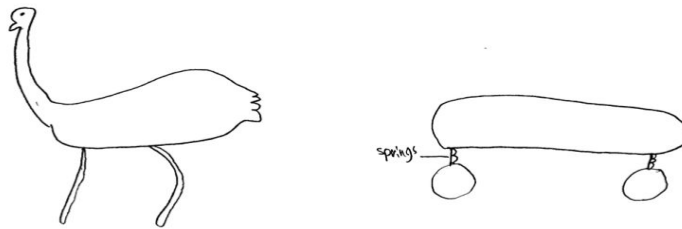

\*Ostrich has long legs that make its body far from the ground which help it to avoid bumps that could affect its movement. So, we can make the car body far from the ground so the child will not feel any bumps. Also, we can add springs to the steering wheels in order to avoid the effect of the bumps.

Figure 27: Ostrich Car

#### 4.11 Design #10: G-Harness/Sensors Car

This is a C-Sketch model and its main features are the harness system and the sensors system. The car has two buttons on each side. The buttons on the right are for speed switch and to take right. The buttons on left are for speed switch and to take left. The sensors were added to prevent collision. The harness system would place the kid inside the car and take him/her out of the car. In addition, the seat will be secured by adding PVC pipes and noodles.

**Advantages:** Sensors would add more safety to the car. Harness system would keep the child secured.

**Disadvantages:** Harness system would make the child feels trapped inside the car and it will not allow the child for more movement. In addition, sensors might need to be replaced regularly which will cost more.

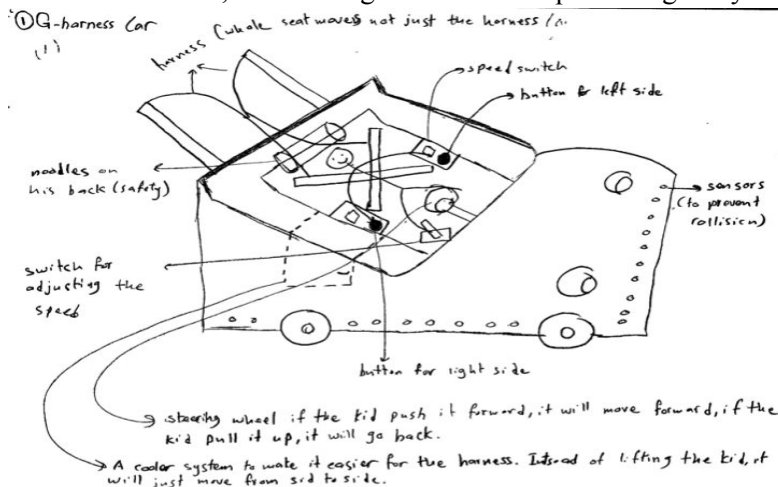

Figure 28: G-Harness/Sensors Car

## 5 DESIGN SELECTED

After collaborating and discussing different designs, the team selected one design to pursue with some different options in mind. The two-button design was selected as the design that the team would continue to work on. However, ideas such as the shell/cover idea from the snail car design, sensors from the gravity harness/sensors car design, and seat belts/supports from all designs are being considered as potential options to add on to the two-button car design.

### 5.1 *Rationale for Design Selection*

The Pugh Chart (Appendix A: Table 2) evaluated a total of 12 designs that were generated using concept generation methods, such as a C-Sketch and Morph Matrix. The designs were compared to a datum design, the Frozen car that the client has in storage. Using the CR's from table 1 each design was given a series of marks, -1, s, or +1. A -1 indicates that the design is worse than the datum at a particular CR. A s indicates that the design is similar or have little difference with the datum for a particular CR. Finally, a +1 indicates that the design was better than the datum for a particular CR. Based on the Pugh Chart the top four designs are: the drag car, the snail car, the 2 button car, and the g-harness/ sensor car.

The top 4 designs were then evaluated using a Decision Matrix (Table 4). Using the CR's from table 1 and their weightings the top 4 designs were evaluated at each CR. The scaling for each CR varies from 1 to its particular weighting. A scale of 1 indicates that the design is poor in a particular CR, while a scale that matches the CR weighting indicates that the design satisfies that particular CR. The totals were then calculated and a relative weight were given based on the final score of the design. The total relative weight has a scaling of 1 to 4. A scale of 1 was given to the design that had the lowest score and a scale of 4 was given to the design that had the highest. The top winner from the Decision Matrix was design # 4: The 2 button car (Figure 22).

**Table 4: Decision Matrix**

CR's	Weightings	# 6		# 7		# 4		# 10	
<b>Cost</b>	4	2	8	1	4	1	4	1	1
<b>Safety</b>	5	5	25	5	25	5	25	5	25
<b>Quality</b>	4.5	2	9	4.5	20.25	4.5	20.25	4.5	20.25
<b>Transportable</b>	3.5	1.5	5.25	1.25	4.38	1.25	4.38	1	3.5
<b>Unique Solution</b>	4	4	16	4	16	4	16	4	16
<b>Lifetime</b>	3	1.5	4.5	1.5	4.5	1.5	4.5	1.5	4.5
<b>Material Accessibility</b>	4	1	4	1	4	1.5	6	1	4
<b>Easy To assemble</b>	3.5	1	3.5	1.2	4.2	1.2	4.2	1	3.5
<b>Control System</b>	3	3	9	1.5	4.5	3	9	3	9
Total:	34.5	21	84.25	20.95	86.83	22.95	93.33	22	89.75
Relative Weight:		2		1		4		3	

Although the 2 button design was chosen the snail and g-harness/ sensor cars have components that could be implemented into the 2 button design. The snail car proposed a glass case that will surround the top half of the car this concept will be modified into the selected design, although instead of the glass case it will be modified into an umbrella attachment. Instead of providing an all around protection for the child the modification will protect the child from the weather. The g-harness/ sensor car proposed a different way for the child to be secured into the car this concept will be implemented into the 2 button car. By having different securement and support options for the parent to choose from. Making the product more adaptable depending on the needs of the child. Along with an adaptable securement and support, the 2 button design will have 2 separate button that control the two 6V motor individually. The buttons will be wireless and therefore movable around the car with an option to have the buttons fixed on a movable armrest. This armrest will rotate from the standard position to a position that rest over the child's lap. The sensors that were proposed for the g-harness/ sensor car will also be implemented into the 2 button design, but the sensors will not be all around the vehicle as that would be expensive and it's installation will be difficult. Instead two sensors will be placed in the front and the back of the car and will alert the parent when the child is near obstacles by sounding an alarm.

The overall selected design is a combination of the 2 button, snail, and g-harness/ sensor designs. It will provide protection from the weather. It will be adaptable depending on the child's needs. Lastly, it will



provide a new dimension of safety by using sensors to alert the parent when the car is approaching an obstacle.

Compared to the other designs this hybrid design is costly as it is not the basic build seen from previous GBG projects. This cost can be justified by the added safety factor that is very important for the project and for the client. It will also add a new way of operating the car with the 2 button system satisfying the unique solution from the CR (Table 1) and the ER (Table 2). As for the other CR's the selected design only varies slightly or not at all. The selected design excels at safety, unique solution, and control system.

## ***5.2 Design Description***

The two button car concept, demonstrated in the CAD package (Figures 29 and 30), show how the proposed car may look after completion. The design includes two armrests each housing different buttons on each side of the kid. The team has considered making these armrests moveable so that they can fit the needs of a variety of kids and allows them to be as comfortable as possible. The buttons will control two separate 6 volt motors on each rear wheel, allowing the car to move forward, with the push of both buttons, and be able to turn at the push of a single button. Sensors will also be added to each corner of the car, being able to detect if the kid is approaching an object and possibly on a collision course; as a safety feature these sensors will act as a kill switch when within a center distance from an object. Next additional railing will be added, made up of PVC pipes and wrapped in pool noodles. As well as a back support board will be added behind the child's head, acting as a headrest. Both the railing and back support add to the factor of safety provided by the car. Every component of the car serves a purpose whether it be safety, accessibility, or just for plain fun.

### ***5.2.1 Website Analysis***

The website is the page that presents the content of the team project for everyone in all over the world. It will let the users of the website to have an idea of what the project is about. However, the website is the gate of the project and the team must make it professional. To make the website professional, the team must think about what makes a website a good one, how does a website connect people and communicate, how far the team reaches in progress of the project, how can that be applied to our website, what improvements could be made, see what the website lack to be professional website.

As a result, comparing all professional websites allow us to learn how to organize and improve our website. In addition, this analysis gave us an experience of how to make the website easy to navigate so that the user will not get lost. For example, if the user wants to find our final proposal for fall 2016 they can go to document page. Document page has two different sections (Fall 2016 and Spring 2017) and all documents for Fall 2016 will be listed there. This example shows that the user can find what is he looking for easily.

### ***5.2.2 CAD Package Analysis***

Using the software SolidWorks a CAD package of the team's proposed design was created. Each component was individually drawn to specifications and put together in a final drawing. The drawings of each component is presented as a schematic with the front, top, and right views in the CAD Analysis report in Appendix B. This CAD drawing provides an actual physical image of the team's project as well as gives a better understanding of how a kid will fit into the car and how each component might be attached together properly.

The results of this analysis not only allowed for different ideas and parts, that the team would design and retrofit for the car, to be placed and attached to the car itself, but would serve as a tool to explain parts of

the car and demonstrate how each added part can be attached. This includes the armrests, sensors, buttons, seat belt, and support attachments. It also was realized that a new CAD package would have to be created in the future after the power wheels car, that the team is working on, was purchased.

### **5.2.3 *Plausibility Analysis***

Plausibility analysis is testing each system and subsystem level to see if the final design will succeed. Performing a plausibility analysis will determine all the advantages and disadvantages of each component of the final design. Also, it will allow to know what difficulties that our team might face, so our team will be prepared to overcome these difficulties. Also, plausibility assessment similarly determines if our process so far has attained expected goals and yet identifies changes that we should make.

The plausibility analysis results allowed the team to have more options about the alternatives that will be available when manufacturing the final design. Also, if any feature of the original design failed, it would be easy to replace it from the alternative options we have and they will be fully studied and prepared to be used at the moment. In addition, the results of this analysis will save time for the team as looking for replacements for the original design because the team will return to this analysis in order to see what options the team have. For example, the team is confused about the button that makes the car moves, but after referring to plausibility analysis, there is an idea about using joysticks instead of button because button are thicker than joysticks, so the idea of using joysticks will allow the team to make the joystick that controls the car movement to be movable and easier for the kid to control it.

### **5.2.4 *Cost Analysis***

The cost analysis part is to get a clear idea of minimum and maximum budget which can be spent on our product, which can go from a minimum of 1500 USD to a maximum of 3600 USD. It's all depend on the quality of parts we use in the development of our product. If we use inferior or low quality parts we can get them in minimum price and by using good parts we can go upto a maximum limit of 3600 USD to get a premium quality product. Another important thing is the use of parts like how many parts we use, for example for securements we can use them as much we want, we can use them in a range of 2-4, which will definitely impact the total price as well.

From this cost analysis, we know that we can find many parts in different price, but the quality will be the big difference between them. For example, we found a button which cost us \$22 and it does the job that we need it for. Also, in the same time we found another button which cost more than \$40, so there is \$18 difference between them for just one button. In our project, we need three buttons, so if we did order the one that costs \$40 then we have to pay \$54 more, so in this case we saved \$54 and if we do that with all parts we need, we will save a lot.

### **5.2.5 *Material Analysis***

The material analysis analyzes the lifetime of the significant materials of the proposed design. The report focuses on the main body of the car and the button that is to be used as the accelerator. As for the other components such as harnesses, supports, and fasteners that are easily replaceable and relatively cheap are insignificant and will not be included in the report. The report has analyzed two children's ride on car: the 12V ride on car, the Costzon Mercedes Benz R199 12V, and the big dome button. The two cars have been analyzed based on ER's and CR's of the project. The important requirements that are to be satisfied are the lifetime of the car, material accessibility, and weight. The 2 cars being analyzed have relatively the same specifications as for lifetime, material accessibility and weight. The two cars would be perfect to use

with our project but the Costzon Mercedes Benz R199 12V gave very little information on its true lifetime and therefore gave a very unclear estimation. However, the 12V ride on car provided a more detailed approximation on its lifetime, through customer reviews and specifications. As for the big dome button, it has given clear specifications and a clear estimation on its lifetime. In conclusion, the 12V ride on car and the big dome button will be used as materials for our project. (Appendix B: Report 5)

## **6 PROPOSED DESIGN**

The proposed final design will be implemented over the following semester. It will start by the team being potentially involved in a Go Baby Go build for a family with the GBG NAU Club, allowing the team to see exactly how a normal GBG car is constructed and the previous components that have been added to them. Then once all components have been purchased and received, the power wheels car, buttons, sensors, and 5-point seat belt will all be order online, the next step will be building multiple prototypes of different components, specifically the functionality of the armrest movement and location of the buttons, the two buttons and their operation with the separate motors, and easy clip-in seat belt types. Once prototyping is complete and all components meet the standards needed, the team will focus on building a car specific to the needs of one client's child, as selected by NAU and the project advisor. This will specify the type of seat, seat belt, and railing that may be needed depending on the child's disability and comfortability with the car. The team will either use the mechanical engineering fabricating shop tools and facility or the team members tools and personal living facilities to construct the car one component at a time ensuring that it functions correctly and is properly secured. Once the final design is fully constructed it can be tested and approved by the client and child. If anything needs to be modified, as requested by the client, the team will be ready to change anything on the car in order to fulfill every customer's requirements. The cost of the final car will be different than the total cost of the whole process of creating the solution needed. Our project funds amounts to \$1,500 and the final design target cost is \$350. This amount will allow the team to test many options as well as the opportunity to prototype in order to select the best overall design for the final product. Since we are performing many solution to each system and subsystem, we will be able to address and define all material costs and choose the best materials that meet the needs of the client, yet remain within the budget. The estimated total cost of the design (Table 5) is \$320, which is below our target cost and allows for some room if added costs arise.

**Table 5: Bill of Materials**

Part #	Part Name	Description	Qty	Item model number	Supplier	Cost
1	Power Wheels Car ✓	(2) 6v motors	1	SKY907	Amazon	\$ 159.99
2	Push Button ✓	Big Red Button	2	COM-09181	Amazon	\$ 44.00
3	PVC Piping	2 in. x 5 ft	2	P002FGP-WH-5	Home Depot	\$ 31.28
4	Pool Noodles	57 in x 2.3 in	2	ATB-73000WN-2pc	Walmart	\$ 21.98
5	Sensors ✓	Car Parking Sensor	1	B00XBXXOPU	Amazon	\$ 18.00
6	5 Point Seat belt	9.4 x 3.6 x 3.2 inches	1	2V-8TCC-ASKP	Amazon	\$ 18.88
7	Optional Cover	Umbrella	1	5J870181	Amazon	\$ 13.90
8	Foam board ✓	1 in. x 2 ft. x 2 ft	1	203553730	Home Depot	\$ 5.98
9	Double Sided Tape ✓	1 in. x 1.6 yds	1	207088689	Home Depot	\$ 4.98
10	Mini Hacksaw ✓	10 in	1	100026795	Home Depot	\$ 8.97
11	Kit	Ultimate Starter Kit	1	B00BT0ND88	Amazon	\$ 48.99
12	Wire ✓	White Primary Wire	1	48243000104	Home Depot	\$ 5.19
13	Splice ✓	15PK	1	32076075040	Home Depot	\$ 2.39
14	Disconn ✓	15PK	1	32076075217	Home Depot	\$ 2.99
15	Set of Nails ✓	125 Nails	1	100113374	Home Depot	\$ 3.87
<b>Total</b>			<b>18</b>			<b>\$ 391.39</b>

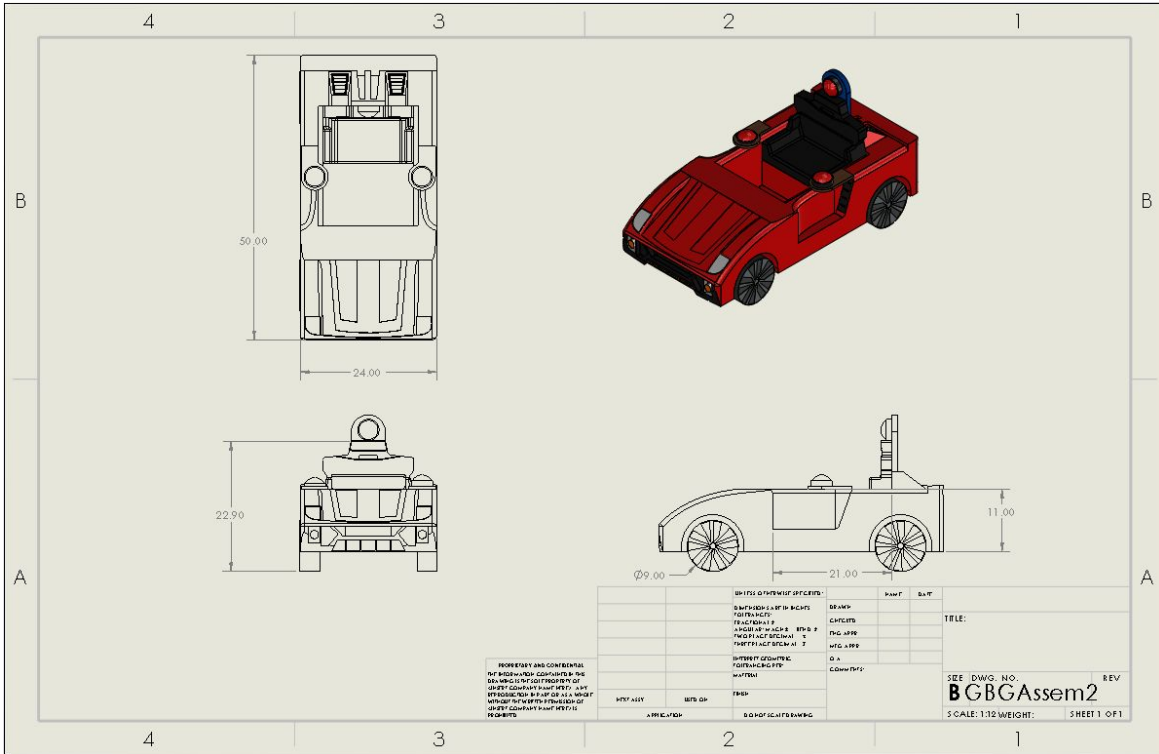

Figure 29: Final Design CAD Assembly View

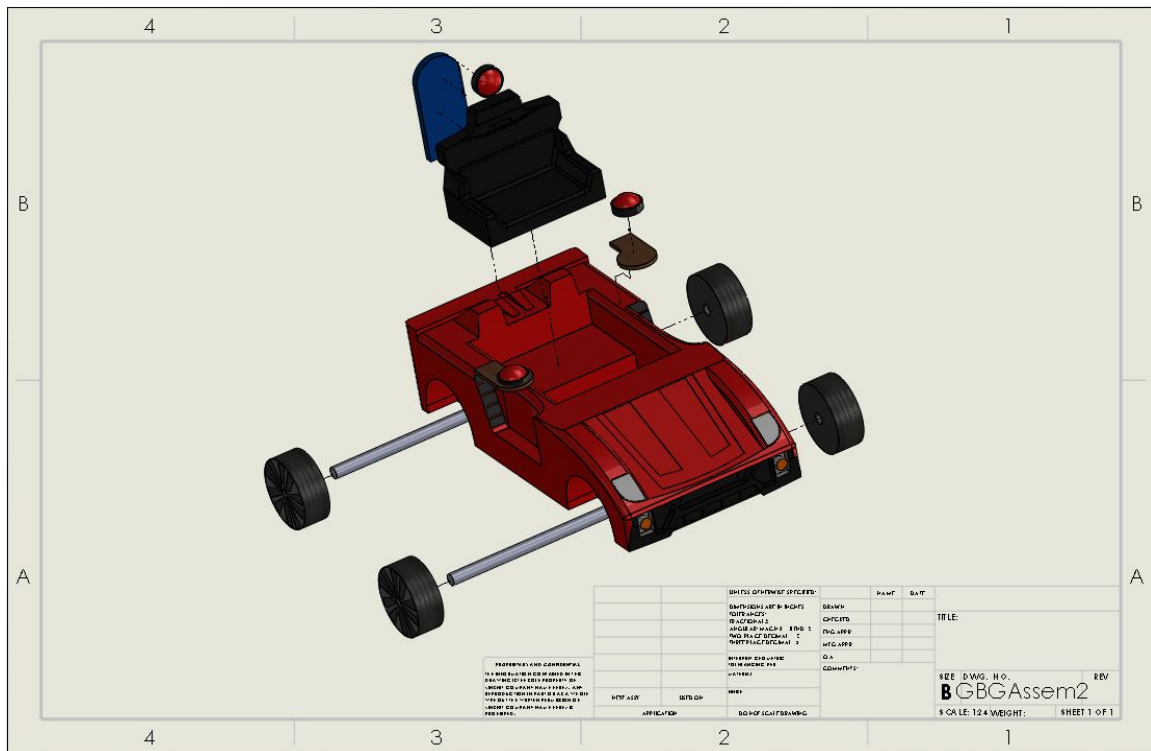

Figure 30: Final Design CAD Exploded View

## 7 IMPLEMENTATION

Implementations are the most challenging part of this project as the team has learned during construction and building of the final design. This section of the report explains how the team built and/or attached each component to the car, as well as how the team will perform a Design of Experiment (DOE) and what are the variables used in order to complete the DOE. One component, the armrests, were built at a team member's garage where the team used various tools in order to cut the wood into the shape that suits the car. The final prototype from last semester was revised, as many other components many need to be as well, to the shape where the two armrests will be separated and attached into the sides of the car.

### 7.1 Design Changes

Design changes is the part where the team makes changes to the original design that was proposed in the first semester from capstone year. The original design had the idea of attaching the armrest in the back of the car and these armrests will be connected together where they will act as a table. This table will have the two buttons on it where the kid can control the car movement by pressing these two buttons. Figure 31 shows a table that combines armrests with a table that was made from wood. However, the team had problems with the table which made it difficult to use the table. For example, the table was covering the stick shift and power button. Figure 32 shows how the team constructed the final prototype that was proposed last semester. After constructing the final prototype, the team did more research on how these armrests should be connected to the car. After discussing all option attached to this process, the team decided that building the table around the car seat would make the kid feels that he/she is trapped inside the car and the two connections that make the table connected would limit the team possibilities on how to add the Five-Point seat belt to the car because the seatbelt will be attached from the back of the car.



*Figure 31: Wood Table Prototype*

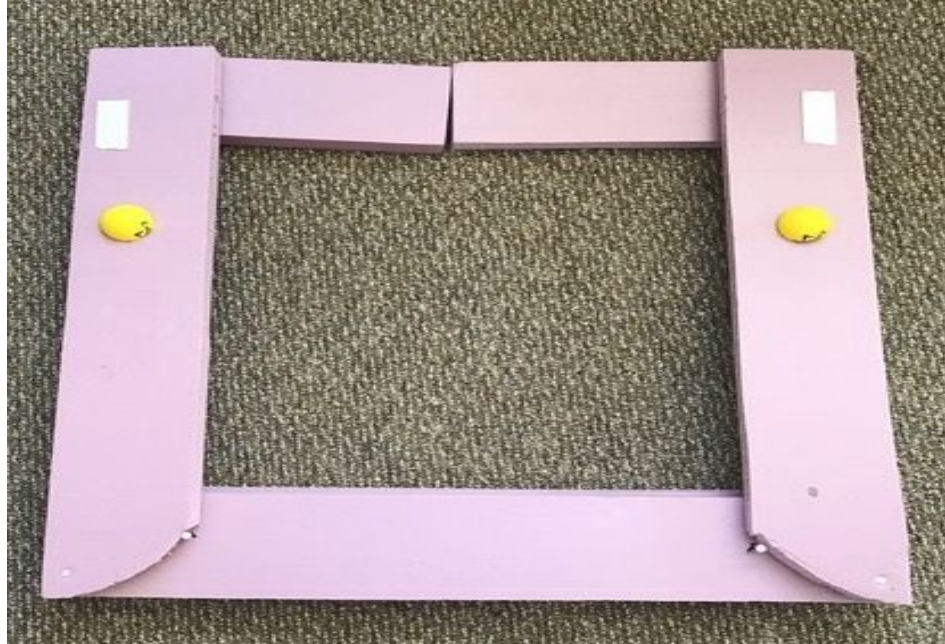

*Figure 32: Final Prototype completed*

At the beginning of week five of the second semester, the team decided to build the armrests for Hardware Review 1 where the team must complete the manufacturing of the design by 65%, so the team's main purpose was to build the armrests because they are the major parts of the design proposed. In order to build the armrests, the team decided to use wood as the material for the armrests because it would be accessible for parents. In addition, the wood can be easily cut and shaped. Moreover, the team decided to make the armrests to be attached to the car without connecting a table with it. Figure 33 shows the final build of the armrests and how they are attached to the car. Therefore, the changes that were applied to the design replaced the idea of having armrests with a table that connect them with just two separate armrests that are put on the sides of the car. This allows for more control on the car movement and helps the kid not to feel trapped inside the car. After Hardware Review 1, the instructor agreed that the team pursues with the idea of having two button that control the movement of the car, but she wants the team to add a third button. This button will control the motors in the back of the car and it will make the car moves forward. In addition, the instructor wants the team to have the car only moves forward and gets rid of the button that switches between moving forward and backward. Also, the team received the new sensors where they will help the kid to stop the car when necessary. After looking at the new sensors, the team decided to have two sensors attached in the front of the car because the arduino software only accepts two sensors which makes it appropriate since the car will be moving only forward.





*Figure 33: Complete Build of Armrests*

## ***7.2 Design of Experiment***

The design of experiment created will model the turn speed of the front steering motor on the power wheels car being used. The design variables include different variations in the Arduino code: built in delays and power directed to motor, as well as variations in the external power given to the motor from the Arduino and a 9v battery, making the number of design variables equal to three ( $n=3$ ). This DOE is two level, meaning each design variable will have two separate values tested and therefore resulting in 8 trials that will each need to be replicated.

These experiments will be done by attaching the 6v steering motor to the arduino, coding the different variations or attaching the different power sources and timing the resulting turn from 0 to 180 degrees. The delay is the amount of time it will take the arduino unit to respond to the button and will vary from 10 to 50 ms. The speed is the amount of power the arduino unit will supply the DC motor with will vary from 155 to 255, half speed or full speed respectively. The battery source will be the battery used to power the DC motor which will vary from 5 to 9 volts. With all these variations the turn speed will be determined using a digital stopwatch with a resolution and uncertainty of .01 seconds. Each trial will be done in a random order as to ensure that equal tests are replicated without the influence of another trial. What variations will be built into the final car will depend on the turning speed that results from these tests; if one set of design variables results in the smoothest reaction and desired turn speed, then the team will choose this set.



**Table 6: DOE Trial 1 Sample**

Turn Speed [s]	Delay [ms]	Speed	Battery Source [V]
Y	10	155	5
Y	10	255	5
Y	10	155	9
Y	10	255	9
Y	50	155	5
Y	50	255	5
Y	50	155	9
Y	50	255	9

## REFERENCES

- [1] Matthew W. Brault, "School-Aged Children With Disabilities in U.S. Metropolitan Statistical Areas: 2010," in [www.census.gov](http://www.census.gov), 2011. [Online]. Accessed: Sep. 25, 2016.
- [2] NAU, "NAU welcomes GoBabyGo mobility program for children with disabilities," 2015. <http://news.nau.edu/nau-welcomes-gobabygo-mobility-program-for-children-with-disabilities/>. [Online]. Accessed: Sep. 15, 2016.
- [3] Northern Arizona University, "GoBabyGo Project Descriptions: ME 476C," Flagstaff, AZ, 2016.
- [4] "Power Wheels®: Disney•Pixar cars 2 Lil' lightning McQueen - shop power wheels ride on cars & trucks," in Fisher-Price. [Online]. Available: <http://fisher-price.mattel.com/shop/en-us/fp/power-wheels%C2%AE%3A-disney%E2%80%A2pixar-cars-2-%3Cbr%3Elil%E2%80%99-lightning-mcqueen-w5541>. Accessed: Sep. 25, 2016.
- [5] TEDMED, "A movement for mobility," in YouTube, YouTube, 2015. [Online]. Available: <https://www.youtube.com/watch?v=joYgbUWiZAI>. Accessed: Sep. 25, 2016.
- [6] R & J Mobility Service Inc. 2016. [Online]. Available: <http://rjmobilityservice.com/mobility-products/driving-aids/steering-devices/>. Accessed: Sept. 21 2016.
- [7] The World Health Organization, Gerontology Research Center, and U. S. Centers for Disease Control and Prevention, "Average height to weight chart - babies to teenagers," in <http://www.disabled-world.com/artman/publish/height-weight-teens.shtml>, Disabled World, 2004. [Online]. Accessed: Sep. 15, 2016.
- [8] S. Logan, H. Feldner, C. Galloway, "Go, Baby, Go! Why the time is Right for a (Radical) Paradigm shift in powered mobility?" [Online]. Available: [http://gobabygo.pl/wp-content/uploads/2014/10/Logan\\_GoBabyGo.pdf](http://gobabygo.pl/wp-content/uploads/2014/10/Logan_GoBabyGo.pdf). Accessed: Sep. 24, 2016.
- [9] J. A. P. Wheelchair, "Power base wheelchair - motorized Wheelchairs," in 1800 Wheel Chair, 1997. [Online]. Available: <http://www.1800wheelchair.com/category/outdoor-power-chairs/>.
- [10] GoBabyGo-PL, "Go baby go PL - One man helped disabled kids with power wheels," in YouTube, YouTube, 2014. [Online]. Available: <https://www.youtube.com/watch?v=qcZtW18WgtE>. Accessed: Sep. 24, 2016.
- [11] DIYAbility, "Go baby go, the ultimate toy hack," DIYAbility. [Online]. Available: <https://www.diyability.org/blog/entry/go-baby-go-the-ultimate-toy-hack/82>.
- [12] "Electric car jeep adapted for special needs," [Online]. Accessed: Sep. 21, 2016. [http://www.scienceshareware.com/adpated\\_pedal.htm](http://www.scienceshareware.com/adpated_pedal.htm).
- [13] A. M. Kravetz and N. S. Foundation, "Toys cars offer mobility to children with disabilities," Live Science. [Online]. Available: <http://www.livescience.com/23572-assistive-robotics-aide-young-children-nsf-bts.html>.
- [14] T. Harris, "How Joysticks work," in Tech, HowStuffWorks, 2002. [Online]. Available: <http://electronics.howstuffworks.com/joystick.htm>. Accessed: Sep. 28, 2016.
- [15] R. Hu, "Learning by leaning: The Dreisch Tricycle rides like a bike," in Core77, 2014. [Online]. Available: <http://www.core77.com/posts/27841/Learning-by-Leaning-The-Dreisch-Tricycle-Rides-Like-a-Bike>. Accessed: Sep. 25, 2016.

- [16] "Ferrari F12 Berlinetta 6V electric children's battery powered under licensed ride on car with (blue) RC remote control radio car," Google+. [Online]. Available: <http://www.nitrorcx.com/28c-81900-ferrari-f12-blue.html>. Accessed: Oct. 1, 2016.
- [17] "DIY Remote Control Car: The Best Tutorial to build an RC Car!," *DIY Hacking*, 2016. [Online]. Available: <https://diyhacking.com/remote-control-car/>. [Accessed: 23-Nov-2016].
- [18] "How to make your rc car faster (electric cars)," [Online]. Available: <http://www.radiocontroltips.com/how-to-make-your-rc-car-faster-electric-cars/>. Accessed: Oct. 1, 2016.
- [19] "Hand controls for cars, trucks, SUVs and vans," [Online]. Available: <https://www.mobilityworks.com/hand-controls/>. Accessed: Oct. 1, 2016.
- [20] "MobilityWorks offers a variety of turning seat and transfer solutions," [Online]. Available: <https://www.mobilityworks.com/seating-solutions/>. Accessed: Oct. 1, 2016.
- [21] Eyekiller, "Scoot mobility rider," 2016. [Online]. Available: <https://www.fireflyfriends.com/us/>. Accessed: Oct. 1, 2016
- [22] Amazon, "Best choice products kids 12V ride on car with MP3 electric battery power, red," in Amazon.com: Toys & Games, Amazon, 1996. [Online]. Available: <https://www.amazon.com/Best-Choice-Products-Electric-Battery/dp/B003Y7NQFC>. Accessed: Nov. 22, 2016.
- [23] Amazon, "Big dome push button - red," in Amazon.com: All, Amazon, 1996. [Online]. Available: <https://www.amazon.com/Big-Dome-Push-Button-Red/dp/B00CYGTH9I>. Accessed: Nov. 22, 2016.
- [24] "2" - PVC pipe & fittings," in Home Depot, 2000. [Online]. Available: <http://www.homedepot.com/b/Plumbing-Pipes-Fittings-PVC-Pipe-Fittings/N-5yc1vZbuf5>. Accessed: Nov. 22
- [25] "2 swimming floating pool foam Noodle swim noodles water float Floatie crafts," in Walmart, 2016. [Online]. Available: <https://www.walmart.com/ip/2-Swimming-Floating-Pool-Foam-Noodle-Swim-Noodles-Water-Float-Floatie-Crafts/132751498>. Accessed: Nov. 22, 2016.
- [26] "Car Rover Car Parking Sensor Reverse Backup Radar Sound Alert LED Display 4 Sensors Black," *Amazon.com: Car Rover Car Parking Sensor Reverse Backup Radar Sound Alert LED Display 4 Sensors Black: Car Electronics*. [Online]. Available: <https://www.amazon.com/Car-Rover-Parking-Reverse-Display/dp/B00XBYXOPU>. [Accessed: 23-Nov-2016].
- [27] "Racing Seat Belt 4 Point Harness - Red," *Amazon.com: Racing Seat Belt 4 Point Harness*. [Online]. Available: <https://www.amazon.com/Racing-Seat-Belt-Point-Harness/dp/B006OVB8C8>.
- [28] "Robot Check," *Robot Check*. [Online]. Available: <https://www.amazon.com/Stephen-Joseph-Little-Friendly-Umbrella/dp/B004LQ1684>. Accessed: Nov, 23 2016.

## APPENDICES

### Appendix A: Charts

*Appendix A: Table 1 - Original System Performance*

		Criteria	Rating (1-5)	Percentage (based on rating)
0-2.5 if > \$200	else 3-5	Cost	2	40.00%
0-2.5 if no padding	else 3-5	Safety	3	60.00%
0-2.5 if not transportable	else 3-5	Transportable	3	60.00%
0-2.5 if <3 years	else 3-5	Lifetime	3	60.00%
0-2.5 if not easily available	else 3-5	Material Accessibility	4	80.00%
0-2.5 if assembly needs an expert	else 3-5	Easy to Assemble	3	60.00%
0-2.5 if there is no a control system for the parents	else 3-5	Control System	0	0.00%
		Total:	18	
		<b>Overall Performance</b>	51.43%	<b>Decent</b>

Appendix A: Table 2 - Pugh Chart

	Datum	Frozen GBG	Stomach	Laying Down	Grasshopper Car	Ostrich Car	Drag Car	Snail Car	Spring Car	Two Bilton Car	Rounded Seat Car	G-harness/Sensors Car	Rounded Base	Basic A4
1. Cost	0	-1	-1	-1	-1	S	-1	-1	-1	-1	-1	-1	-1	-1
2. Safety	0	-1	-1	-1	S	-1	1	1	-1	1	S	1	S	S
3. Quality	0	S	S	S	S	S	S	1	S	S	S	1	S	S
4. Transportable	0	S	S	S	S	-1	-1	S	S	S	S	-1	S	-1
5. Unique Solution	0	1	1	1	1	1	1	1	1	1	1	1	1	S
6. Long Life Time	0	S	S	S	S	S	S	-1	S	S	S	-1	S	S
7. Material Accessibility	0	-1	-1	-1	-1	S	-1	-1	S	-1	-1	-1	S	S
8. Easy to Assemble	0	-1	-1	-1	-1	S	-1	S	-1	-1	-1	-1	-1	S
9. Control System	0	1	S	S	S	S	1	S	S	1	1	1	S	1
	Negative (-)	4	4	4	3	2	4	3	3	3	3	5	2	2
	Same (s)	3	4	4	5	6	2	3	5	3	4		6	6
	Plus (+)	2	1	1	1	1	3	3	1	3	2	4	1	1

**Appendix A: Table 3 - House of Quality**

Customer Requirement	Weight	Engineering Requirement	# of Securements	# of Supports	Weight of Car	Unique Solution	Adjustable Speed	Material Access	Assembly Time	Adaptability	Significant Materials Lifetime
1. Cost	4	Material Cost	3	3				2			3
2. Safety	5		5	5	3						4
3. Quality	4.5						3				4
4. Transportable	3.5				5						
5. Unique Solution	4					5	4				
6. Long Life Time	3										5
7. Material Accessibility	4		5					5			
8. Easy to Assemble	3.5			2					5		
9. Control System	3					5					5
Absolute Technical Importance (ATI)		80.5	44	44	32.5	35	44.5	28	17.5	15	65
Relative Technical Importance (RTI)		10	8	8	6	7	5	4	3	2	9
Target(s), with Tolerances)		\$350, < \$400	3, >2	3, >2	60 lb, <100 lb	Unique from past GRG solutions, Unique	Starting speed of 1 mph, < 2 mph	Local store, <3 weeks	2.5 hr, < 4 hr	4, > 4	3 years, > 5 years
Testing Procedure (TP#)		1	2	2	1	3	3	1	3	3	1
Design Link (DL#)		1	2	3	1	4	4	1	1	4	1

## Appendix B: Analytical Reports

### APPENDIX B: REPORT 1

#### Website Analysis

The website is the page that presents the content of the team project for everyone in all over the world. It will let the users of the website to have an idea of what the project is about. The first thing that comes to mind when a person has not heard of the project is to look at the project website. However, the website is the gate of the project and the team must make it professional. To make the website professional, the team must think about what makes a website a good one, how does a website connect people and communicate, how far the team reaches in progress of the project, how can that be applied to our website, what improvements could be made, see what the website lack to be professional website. One of the ways is to go to professional website like (Gore) and see how they designed their website to get more idea of how to improve our website. Another way is to give the website users an idea of our project by uploading a video of our design and how we implemented it. All of these are ways to improve our website.

To make the website a professional one, the team should upload a video that explains how the team implemented the project. The video will summarize all the progresses that the team went through to design the car. In addition, selecting the right images for the website will attract the users. In Figure 1, Gore company uploaded a video on the home page to make it easier for the users to know their work.

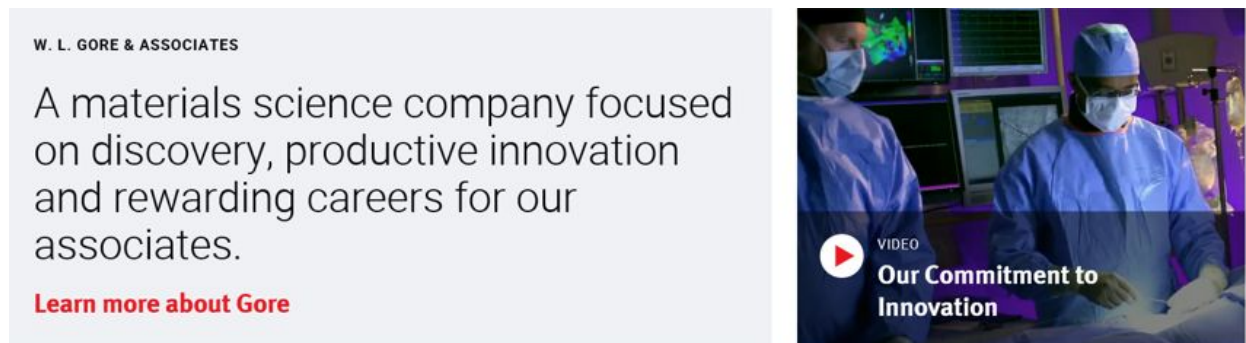

Figure 1: video uploaded in homepage for Gore website [1]

Since the website gives an idea for the users, it is important to provide a way for users to communicate with the team if they have any questions or want information and there are many ways to do that. One of the ways is providing a contact section on the website which has emails for questions or suggestions. As seen in Figure 2, the team can provide options before they ask to know exactly what do they need for example: project information, budget, etc.

Navigations is an important thing since it is hard to find information in some websites. The team focused on how to make the website clear as much as possible so that users can move around the website easily. Following the 'three click rule', which means users will be able to find the information they are looking for within three clicks [2].

# Contact

Gore has built a worldwide reputation employees.

**What can we help you with? \***

- Product information / a quote
- Career opportunities at Gore
- Verify employment of a Gore associate
- Accounts payable / accounts receivable
- Become a vendor / supplier
- Corporate address
- Other

Figure 2: Gore contact section [1]

For homepage, the website must have a brief summary of the project and logo that presents the team and the goal of the project. The team added documents section, so that the users can look for a final report of the project, gantt chart, etc. In addition, adding a gallery section is an easy way to talk about the project in terms of pictures. By comparing GobabyGo website and Gore website, we can see that they both have almost same categories, video tape in homepage, and contact information. Since Gore is a professional website, the team should improve similar things between GobabyGo website and Gore website to reach the professional level. In addition, both of them have a description on the home page which describes their work in a brief paragraph.

By comparing the differences between both websites, Gore has a resources category which helps users to find more information about what they are looking for. As seen in Figure3, they have provided multi-languages which make it easier to read for users from all over the world instead of using one language. Gore website provides images on the homepage about their products and achievements which will attract the users to spend more time moving around the website.

### Language

- CHINESE (6)
- DUTCH (5)
- ENGLISH
- FRENCH (10)
- GERMAN (11)
- ITALIAN (3)
- JAPANESE (7)
- KOREAN (3)
- POLISH (9)
- PORTUGUESE (6)
- RUSSIAN (14)
- SPANISH (11)
- SWEDISH (6)

Figure 3:languages preference for Gore website[1]



The reason of looking for similar and different things between GobabyGo and Gore website is to help the team to find what the website needs to be professional and how it can be improved. However, having a professional website will attract more users and will help the project to succeed because every successful company have a professional website. For example; having the contact section will let the users send their questions and suggestions which will help the team improve the project.

### **Work Cited**

[1] Gore.” Improving lives through advanced materials”. [online], (2016). Available: <https://www.gore.com>. Accessed: [Nov 13,2014].

[2] S.Wood,” 10 Top Principles of Effective Web Design “. SHORTIE DESIGN, (March 4,2014).[Online] Available: <http://shortiedesigns.com/2014/03/10-top-principles-effective-web-design/>. Accessed: [Nov 12,2014].

## ***APPENDIX B: REPORT 2***

### ***CAD Package Analysis***

This analysis takes into consideration the design of the team’s final proposal and brings it to life. Up to this point the team has only produced rough sketches and written down different concept ideas of what the final product might look like, however with the use of the program SolidWorks a computer aided design (CAD) was produced to demonstrate how the final product might actually look. This CAD drawing will allow the team to design and try out different components, some of which are included already, on the final car to evaluate if they will actually function, in theory.

The CAD package created assumes that the team will be using a single seat power wheels car with two 6 volt motors. It takes into consideration the basic dimensions of a basic power wheels car [1], but has a basic overall frame of a sports car. It also takes into consideration some of the key components that make this design unique from past GoBabyGo (GBG) designs.

The frame or base of the car is dimensioned off of a mustang power wheels car and with appropriate wheels [2]. The car follows the model of other GBG cars, but incorporates the new two-button seat, 5-point seat belt, and the protective/more accessible PVC doors. The seat is built with arm rests that house the two button system; this two button system will operate the different motors to move and steer the car, replacing the standard steering wheel. The standard doors on the car have been removed and replaced with PVC doors that are wrapped in pool noodles, for safety, and have the ability to swing 180 degrees when they open. These CAD drawings is seen in the appendix on the following page. Some components that have not yet been built into the system are the sensors that will help to indicate when a kid is too close to another object and the different harnesses or seat belts.

The process of creating this design started with the base of the car and making appropriate dimensions. From there all other components were dimensioned and built based upon the frame of the car. All parts were created separately and even added had some color added to them to make them appear as they would when the final product is actually constructed. Once all parts had been built, the final CAD package was assembled so that all parts came together to display the final design.

This CAD package design not only brings the team's ideas closer to reality, but it also provides some insight as to some challenges they may face. After examining the CAD package the team came up with multiple components that could be prototyped to better understand if and how they will actually function. In particularly the harnessing system and how it will be attached to the vehicle, and what type of arm rests that could be built either directly attached to the seat or ones that attach to the frame and fold up. Realizing these potential problems will help the team to have less difficulties and struggles down the road to the final completed design.

### Appendix: CAD Drawings [dimensions in inches]

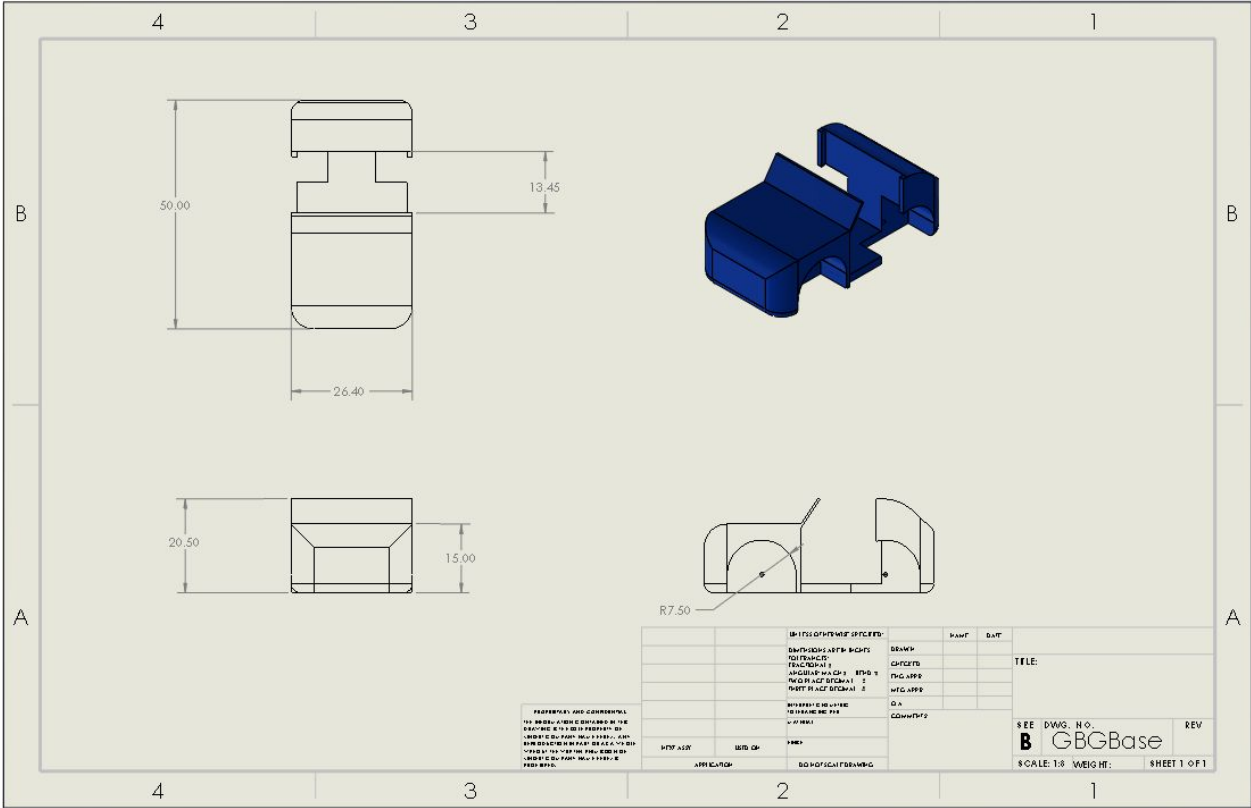
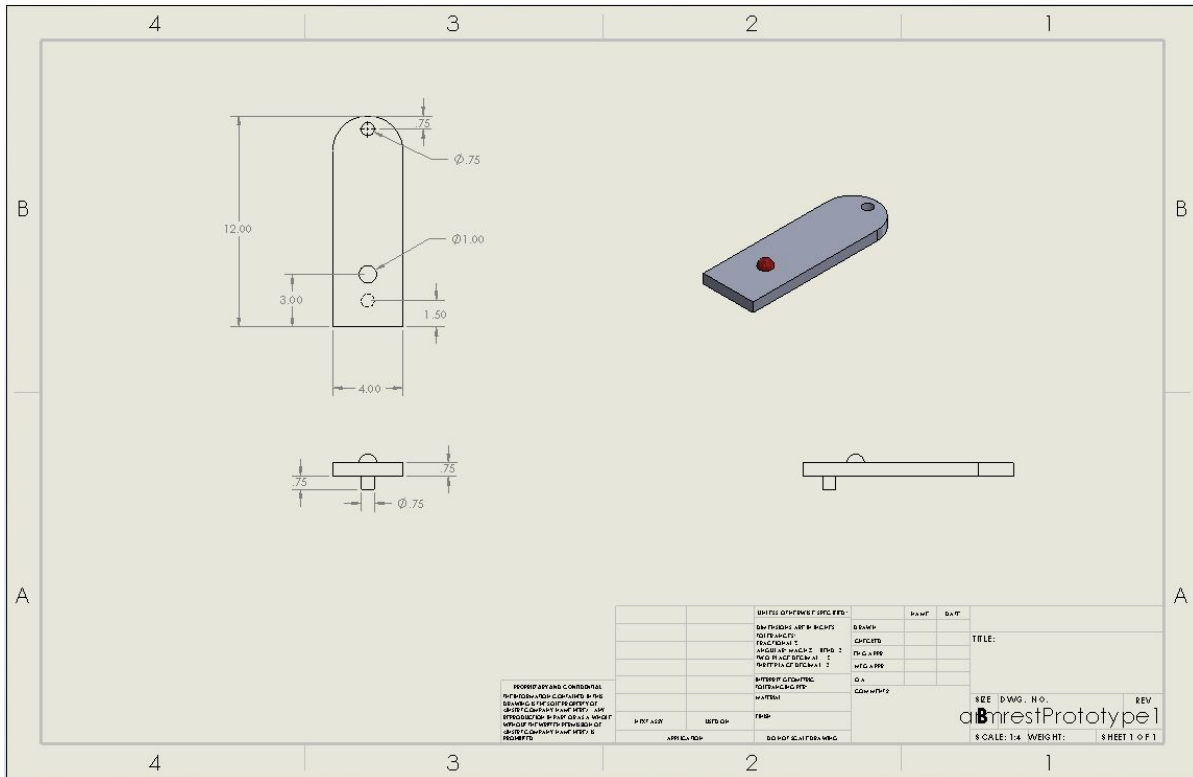
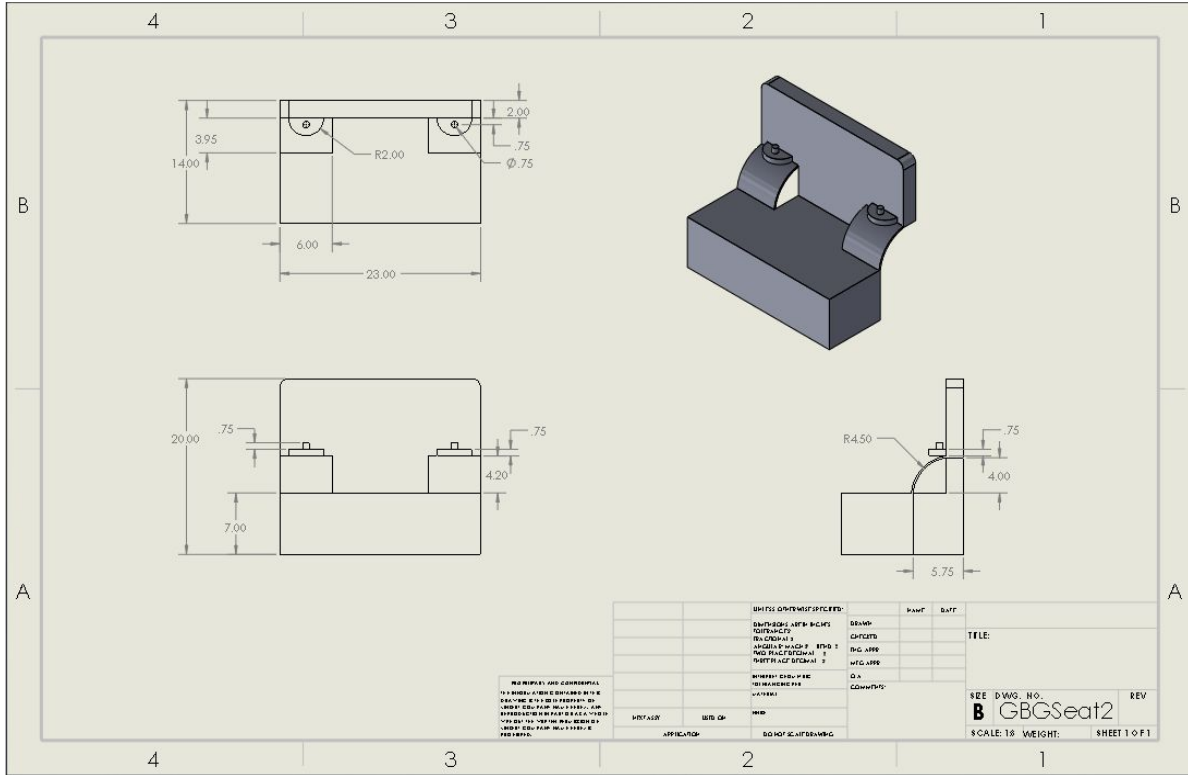

Figure 1 – Car Frame



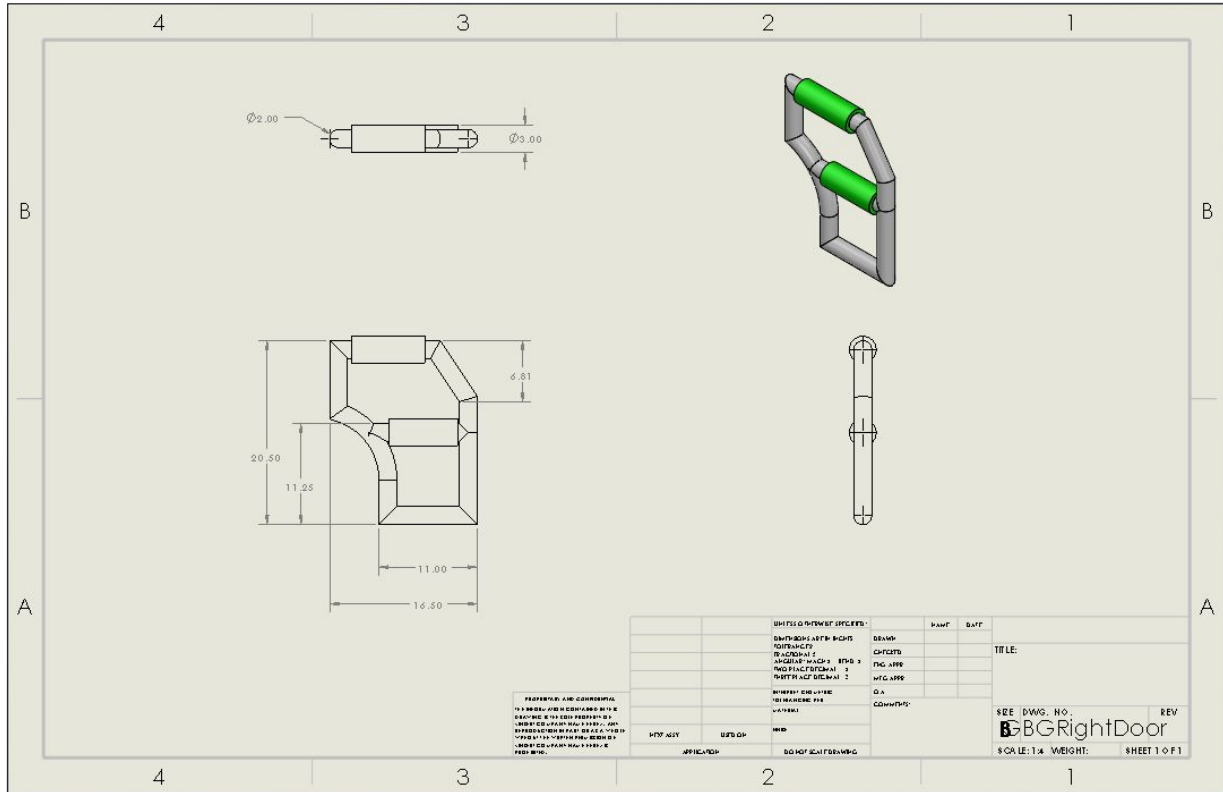

Figure 3 – PVC and Pool Noodle Car Door

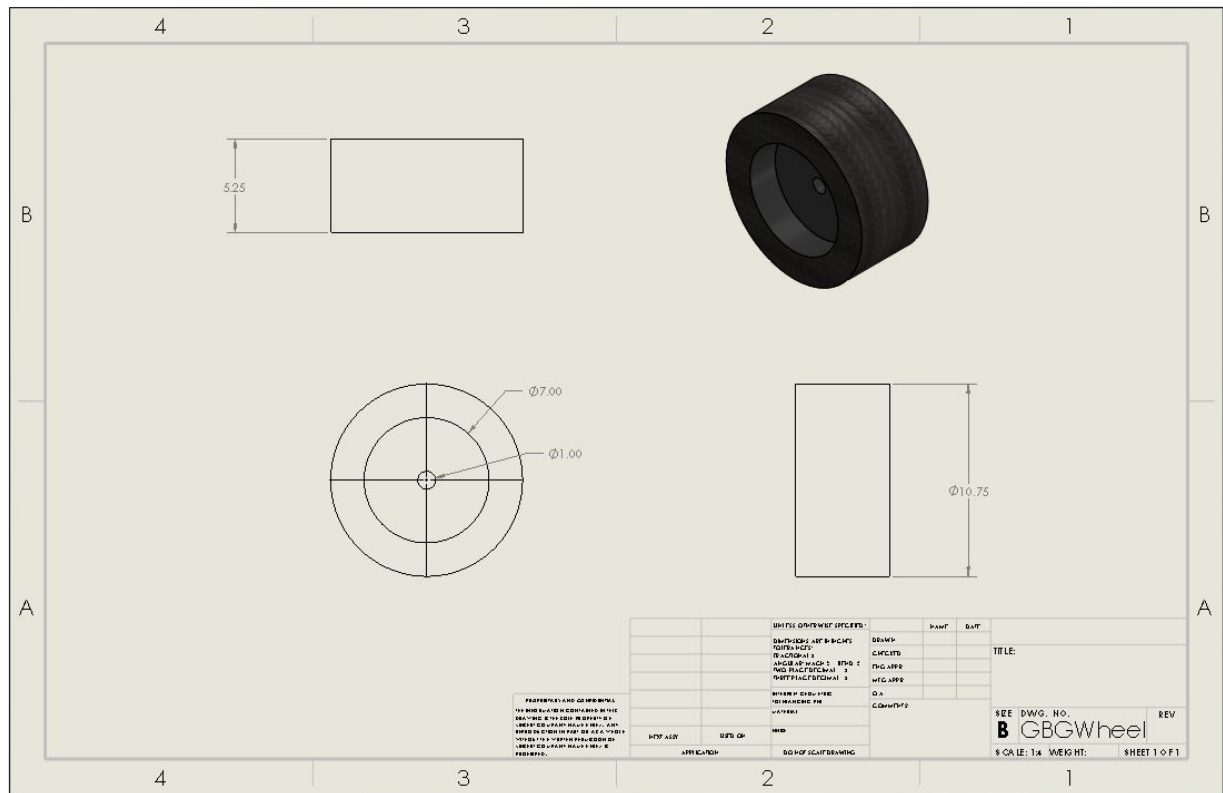

Figure 4 – Car Tires

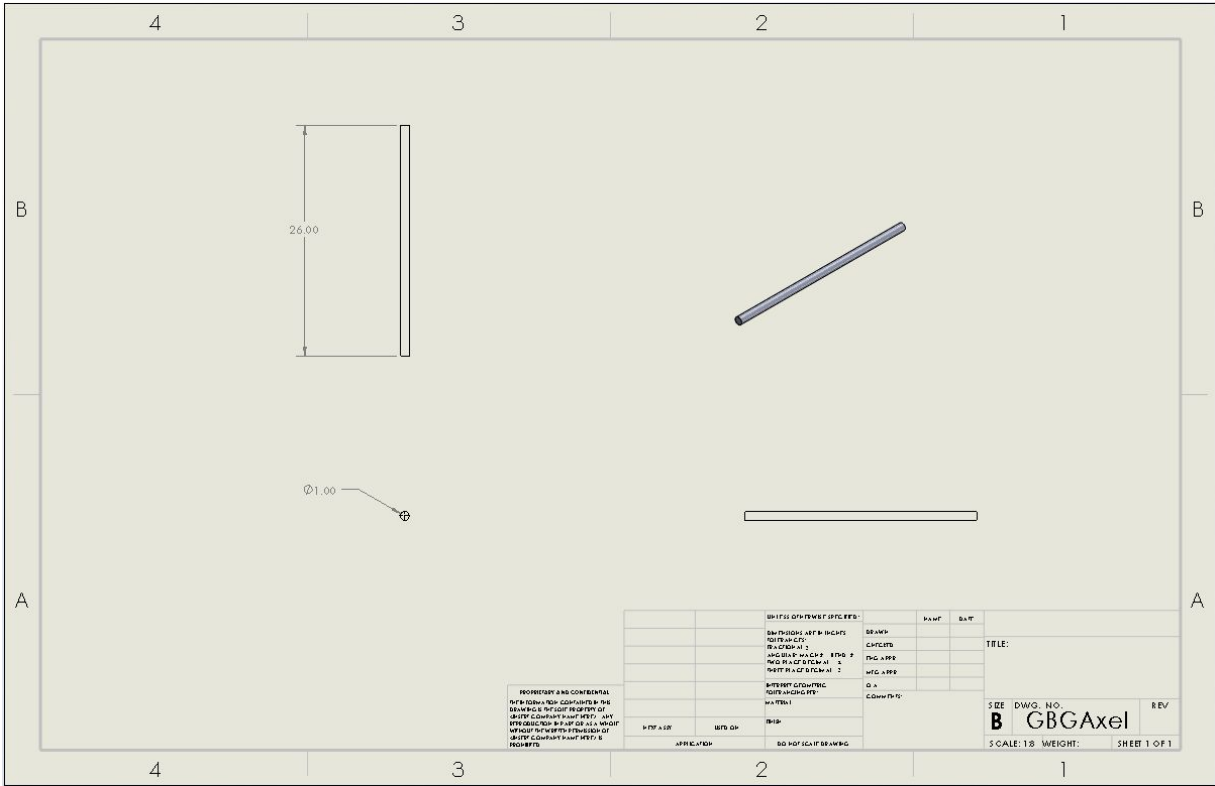

Figure 5 – Car Axle

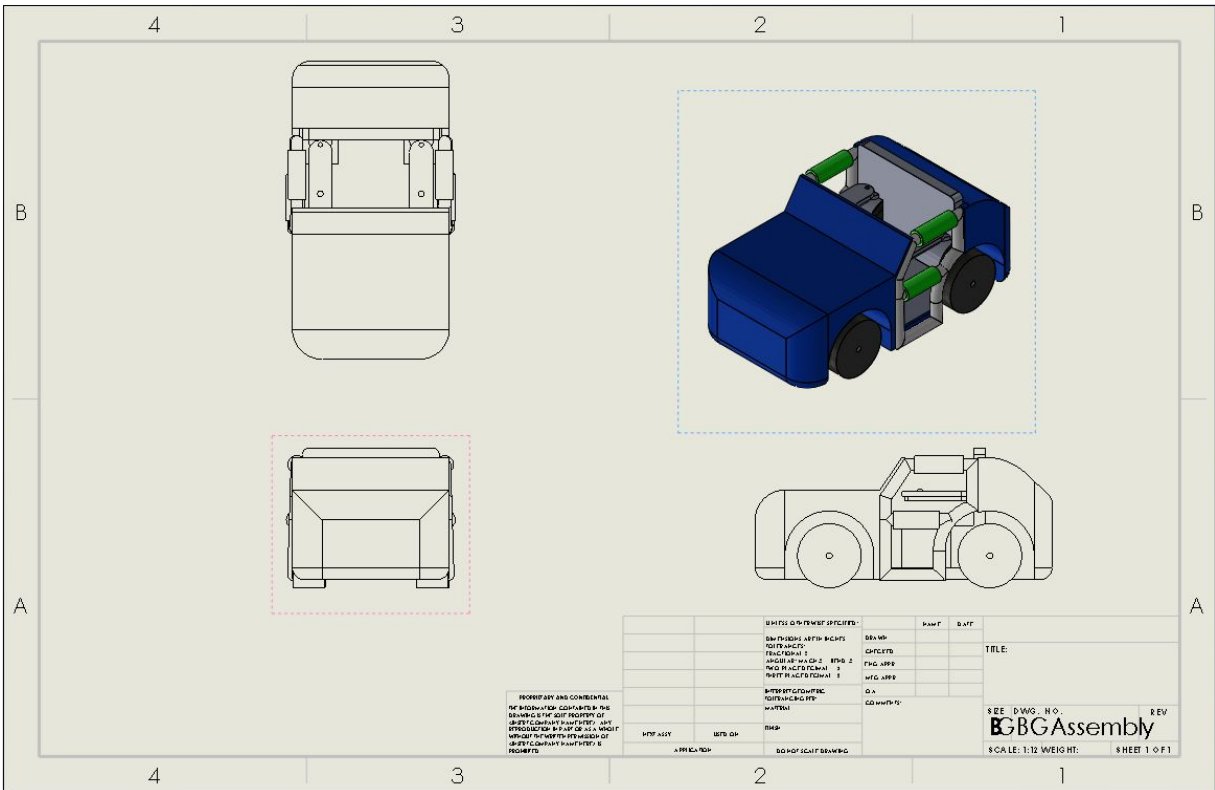

Figure 6 – Final CAD Design Assembly

## References

- [1] "Power wheels Ford Mustang powered ride on," in *Toys-R-Us*, 2016. [Online]. Available: <http://www.toysrus.com/buy/powered-riding-toys/power-wheels-fisher-price-ford-mustang-p5920-3909348>. Accessed: Nov. 17, 2016.
- [2] "Power wheels H8256-2459 wheel-tire," in *Hobbymasters*, 2016. [Online]. Available: <http://hobbymasters.com/power-w>

### ***APPENDIX B: REPORT 3***

#### ***Plausibility Analysis***

Disability is defined as a person who has a physical or mental impairment that substantially limits one or more major life activity. Many children around the world are born with different disabilities. These disabilities prevent children from having a normal life and make them feel isolated from their surroundings. Enabling those children to have self-control of their surroundings will have great impacts on the long term and not to feel inferior from their peers. GO Baby Go (GBG) foundation was created in 2012 at the University of Delaware. They started with developing a set of Do It Yourself (DIY) cars. These cars were created to enable young children to move and interact with their peers. The goal of our project is to design and build a new version of the GBG retrofits for children that limited mobility of their arms and/or legs.

This report will be talking about plausibility analysis. The aspects of different options, what would be realistically possible to do with our design and what have less plausibility. Analyze each subsystem that would be in our design and how to avoid failure of those subsystems. Analyze design selected and how it could be put together. What difficulties might our team face when putting together the final design? What options our team have to overcome those difficulties?

The purpose of this report will be to relate the outcome of this report to our project and how we can implement these outcomes to benefit the purpose of this project to come up with the best solution that would help disabled children to have a better life. Also, plausibility assessment similarly determines if our process so far has attained expected goals and yet identifies changes that we should make. For this assignment, we are developing Plausibility Analysis, Cost Analysis, Materials Analysis, and CAD package Analysis. Putting together all the outcomes of these reports will benefit the process of creating the best solution for GBG cars. Also, it would determine what materials that we will need for prototyping. Each analysis is important towards our project, so we are putting huge efforts in it.

In the Preliminary Proposal, our team developed a set of concept generation. We used some methods to come up with as many as concepts we can. This is a complicated project and in order to create the solution needed, we had up to 25 concepts. Each concept represents a solution by itself. We used some creative techniques to generate these 25 concepts. We used C-Sketch techniques where team member drew a full concept and then the other members added to or modified the concept. Also, we used Bio-Inspired designs technique to relate the nature to our project. In addition, we performed a Morph

Matrix technique in order to have more options of the subsystem level of our design. After gathering all the concepts, we created a Pugh Chart and Decision Matrix to evaluate all the concepts. Our datum for the Pugh Chart was the previous frozen car that the previous GBG team created. After evaluating all the concepts, we found that not all the concepts can be implemented towards our design, so we started gathering ideas from all the concepts and tried to put what we need in our final design. This process will allow us more alternatives if any of these ideas failed.

Performing the Pugh Chart analysis led the team to what is the main idea of our final design would be. Most of the concepts selected for the Pugh Chart were new solution that never been used in a GBG cars before which makes it more complicated to adapt. Then, we did the decision matrix analysis after picking up the top five concepts from the Pugh Chart. In the end, the concept with the idea of using two buttons was selected for the final design. Now, I will discuss each idea we have for the selected design and what advantages and disadvantages each idea have. Also, I will discuss ideas that were not selected for the final design because they might be considered as alternative options in case the selected ones flailed.

### **Design Selected: Two-Button Car**

Steering wheels sometimes can be difficult for children with disabilities to control the car because their disability prevent them from having a full control of the car. The solution proposed by our team is to have two buttons to control the car instead of the steering wheel. River is one of the cases that were presented by our client. Rives cannot use her arms to control the steering wheel because her arms are bend in a way she cannot rise them for a long time. So, the idea of using two buttons would be a replaceable option for the steering wheel. These two buttons can be put on the armrest in the car or they can be put under the seat, so the location is dependable of the child condition. Each button would be connected to a 6V motor. The process of moving the car would be the right button would make the car move to the right and the left button would make the car move to the left. Another feature of the design is to add an umbrella to the car. This idea came from a Bio-Inspired design where snail hides inside his shell in case of danger. This umbrella will protect the child from sun in case of hot days and also will protect him in rainy days. The last feature proposed to the final design is having 180° doors. This feature will allow the kid to interact with the surroundings in case he/she wants to touch the grass around. Below is Figure 1 (Two-Button Car) and main feature discussed.

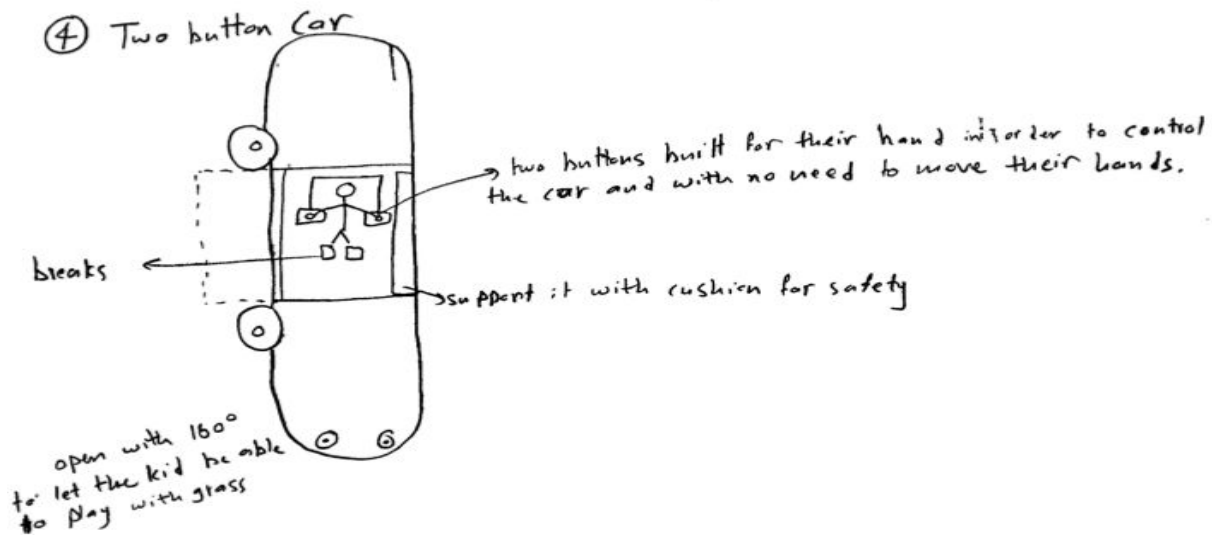

Figure 1: Two-Button Car

## Two-Buttons

**Advantages:** It would be suitable for children who cannot raise their hand and it would make them have full complete of the car movement. Also, GBG club has reached a solution for the button size. They tested a button that is smaller in size and much cheaper than the current one. The button they tested is worth 8\$ and the current one is worth 80\$.

**Disadvantages:** The location of the buttons would be an issue because if we put them on the armrest, the size of the buttons would make it difficult to make the buttons fit within the car body.

## Umbrella

**Advantages:** It would protect the child from outer objects. For example, it would protect him/her from sunrays in hot days and from rain. Also, we are thinking to make the umbrella not to be attached to the car to give parents more options about adding it to the car when needed. An option for the umbrella material would be plastic because it is light and can be shaped and modeled to fit in within the car.

**Disadvantages:** The materials used to create this umbrella would be an issue because we need to use light material that can stand still when the car is moving. The maximum speed that that the car can go is 2.5 mile/hour, so we must use materials that can stand still that speed.

## 180° Doors

**Advantages:** It will allow the child to get out of the car easily and it would make it easier if the child wants to touch the grass or the ground. Adding a hinge to run the doors smoothly.

**Disadvantages:** Adding two doors to the car would interrupt the wiring system of the car. For example, if the door is added, we must find a different path for the wires, which will be the sill.



## **PVC Pipes & Swimming Noodles**

**Advantages:** They will provide more safety to the rider and they will prevent him/her from getting hurt in case of collisions. Also, adding swimming noodles to the car from inside will help the child to have more control over the car and not to move back and forth.

**Disadvantages:** We must implement the size of the PVC pipes and the noodles to make them fit in within the car which will take more time to model them to fit the car as wanted. Also, having more pipes and noodles in the car would make the child feels trapped inside the car and not having more space to move.

### **Different Options to Consider in Case Design Selected Failed:**

Since our selected design has not been created and tested yet, we must have some alternatives to replace the original design because at that time we will not have enough time to generate a new design because next semester we will be too busy working on the original design and how to make it works. This step will save us time and money because having alternatives will benefit the final design as a whole and it will not make us panic because the original design failed. Also, if any feature of the original design failed, it would be easy to replace it from the alternative options we have and they will fully studied and prepared to be used at the moment. Below are the alternative options discussed.

### **Joysticks**

**Advantages:** In case of the button solution failed, adding one or two joysticks will be a perfect alternative. Joysticks are easy to control and they can be moved in all direction. When using the button, we have to come up with a way to make the car move backward not just forward and joysticks do the same feature perfectly.

**Disadvantages:** The size of the joystick would be a problem because it must be suitable for children's hands in order for them to control the car. Also, connecting the joysticks to the motors require more knowledge of how the system would work when using them.

### **Glass Shell**

**Advantages:** Glass shell is a secure feature that can be used to have more safety for the rider. In case of strong collision, the child would be secured inside this shell. Also, it would make him/her feel secured inside it.

**Disadvantages:** The material that would be used to create this shell might be expensive. For example, using glass would cost much money because it needs to be shaped to fit the car body. In addition, adding this glass shell would make the car heavier and it would take long time to assemble it.

### **Sensors**

**Advantages:** Sensors are used in the new car designs. They provide more securement to the rider. We would add sensors to the car to have the car stops when the kid does not stop and he/she is about to hit something. Also,

**Disadvantages:** Connecting the sensors to the car system would be an issue because we must find a way to cut the power as long as the car approaches an object. Also, the quality of the sensors must be high which will cost more money.

### **Remote Control**

**Advantages:** This remote control will allow the parents to turn on and turn off the car. Also, it would give them more option to modify the car path. In addition, it would make the parents feel safe and not to worry about the car movement.

**Disadvantages:** It might make the child hates riding the car because someone else can have control over it. Most importantly, the distance where the remote control works is a huge problem because the parents must be near the car to have the remote control functions properly.

## ***APPENDIX B: REPORT 4***

### ***Cost Analysis***

We have analyzed the requirements of our customers and based on that we can say that cost is one of the most important factors for a client for purchasing any vehicle, based on it, purchasing quantity of a product can be increased or decreased. We have analyzed that the price of a product should lie between 1500 to 4000 USD.

According to our estimations the material cost for the vehicle should lie between 350 to 400 USD, we aim to create it in the lower threshold. The cost can also vary on the number of securements, which can based on customer need as well, we have decided to put 2-4 securements, and it depends on the need so its price should vary between 80 to 160 USD. Another important thing for a vehicle is the availability of supporting parts, we will be using PVC and pool noodles, which will help child to operate the vehicle. If we use good quality parts it will cost a bit higher while if we use low quality or intermediate quality parts, they can reduce the cost to a great extent. Depends on the quality we parts used, it can cost between 500 to 900 USD.

Weight of the product must be between 60 to 100 LBS, but it should be minimum so that a child can easily bear the weight and can control the vehicle easily, it will also put an effect on the material used, because quality of material can increase or decrease the weight of vehicle accordingly. The material used by the vehicle should be available easily at local stores, but if it's not available easily and if needs shipment, it will put an overhead of price and a shipment price will be needed and will also take some time for shipment. The target lifetime of the vehicle is at least 3 years so parts used in manufacturing must be good so that it can easily fulfill the lifetime of vehicle.

Let's have an overview of the cost which we will need in order to develop a vehicle.

Requirement	Price Range
<b>Material cost should be between</b>	300 – 400 USD
<b>Securements</b>	400 – 1000 USD

<b>Support Parts</b>	500 – 1200 USD
<b>Material accessibility</b>	0 - 200 USD
<b>Adaptability</b>	100 – 400 USD
<b>Others</b>	200 – 400 USD
<b>Cost Analysis</b>	<b>1500 – 3600 USD</b>

Based on the above calculations we can see the vehicle can be prepared in the range given above.

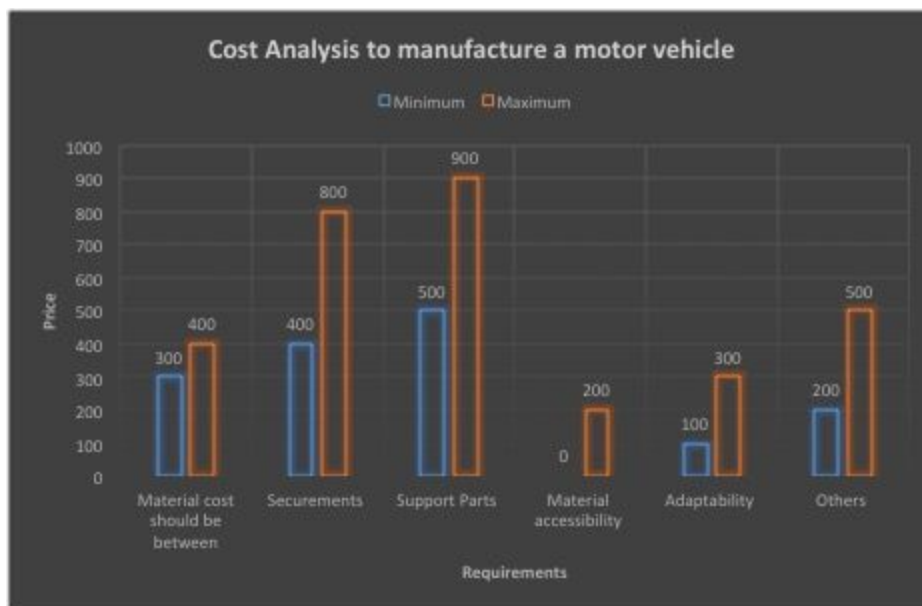

The above given chart represents the cost analysis to manufacture a motor vehicle in a graphical form, As we can see that the blue bars represents the minimum cost level for a certain category, whereas orange bars represents the maximum cost for the category which can be applied to assemble a motor vehicle for children.

To manufacture a motor vehicle minimum cost for the material to purchase is 300\$, at least 400\$ are required for the securements of the vehicle like seat belts, noodles e. t. c. Minimum 500\$ will be the cost for the support elements in the vehicle. Accessibility of the material depends on your location if you are living in an area where these kinds of things are easily available then there would be zero charges for the shipping. Moreover adaptability and other such components will require 100\$ and 200\$ for the motor vehicle at least. So at the end of our cost analysis we can say that minimum 1500\$ are required to manufacture a motor vehicle for the children. Just by looking at the graph we can see that if we wanted a premium style vehicle with maximum comfort and supports it will cost up to 3600\$.

## ***APPENDIX B: REPORT 5***

### ***Material Analysis: Lifetime of Significant Materials***

## **1 BACKGROUND**

According to the United States Census Bureau there are “53.9 million school-aged children (ages 5 to 17) in the U.S. civilian noninstitutionalized population, about 2.8 million (5.2 percent) were reported to have a disability in 2010” [1]. Many of these children live with physically debilitating disabilities that affect their daily life. These disabilities range from minimal to severe physical barriers; spina bifida, cerebral palsy, down syndrome, hypotonia, and etc. GBG’s (Go Baby Go) purpose is to “foster [the children’s] physical and cognitive development” [2] through the use of an assistive vehicle.

### **1.1 Project Description**

Following is the original project description provided by the sponsor:

“Children with limited mobility often do not receive the much needed exposure to socialization to appropriately cognitively develop. Existing research shows that enabling young children with self-control of their own environment can have meaningful impacts on the long term outcomes given such impairments as cerebral palsy or muscular dystrophy. The Go Baby Go (GBG) project that started at the University of Delaware has developed a set of DIY cars for families with children with mobility restrictions. These cars have been designed on commercially available ride on toy car platforms (like Power Wheels) and have been deployed worldwide by the GBG team. These cars have shown to be a cost-effective means of enabling young children to move and interact with their peers.

The goal of this project will be to design and build a new version of the GBG retrofits – specifically to design a universal control for children that extremely limited mobility of their arms and/or legs [3].”

This team hopes to take the platform of cars and previous designs and create something unique that will not only be adaptable to children with a variety of disabilities, but provide them with a new tool to develop more upon their cognitive, social, and physical skills.

## **2 Customer Requirements**

The customer requirements shown in table 1 were taken from the previous preliminary report. The CR’s listed are the CR’s that pertain to the selection of the main body.

***Table1: Customer Requirements and Weightings***

<b>Customer Requirements</b>	<b>Weighting</b>	
<b>Longlife Time</b>	3	8.70%
<b>Material accessibility</b>	4	11.59%

**Longlife** - The lifetime of the material is important as the child will need to be able to use the finished product for a number of years. As the finished product will help the child with their physical therapy and promote self decisions, as they use the vehicle.

**Material accessibility** - The product must be accessible for all parents. Therefore materials are limited to pre made parts and must be available in local and web stores.

### 3 Engineering Requirements

The engineering requirements shown in table 2 were taken from the complete engineering requirements table from the previous preliminary report. The ER's listed are the ER's that are significant for choosing the appropriate main body for the proposed design.

*Table 2: Engineering Requirements with Targets and Tolerances*

Engineering Requirements	Target	Tolerance
Weight of Car	60 lbs.	< 100 lbs.
Material Access	Local Stores	Shipping < 3 weeks
Significant Material Lifetime	3 years	> 5 years

**Weight of Car** - The target of 60 lbs. considers the entire build of the car, including but not limited to PVC pipes, pool noodles, and different securements. For the purpose of the analytical report there will be a limit on the weight of the main car to 50 lbs. with the assumption that the other materials will weigh 10 lbs. combined.

**Material Access** - The materials needed to build the product must be easily obtained through local stores or online shops with a tolerance of 3 week shipping.

**Significant Material Lifetime** - The significant material for the project will be the main car itself. The car must have a lifetime of 3 years with a tolerance of > 5 years.

### 4 Material Analysis: Lifetime

The analysis will look at the proposed design and determine the significant components. Significant components are materials that are expensive and are difficult to replace. Therefore components such as PVC pipes, pool noodles, and securements, such as seat belts and locks, will not be included in the lifetime analysis.

#### 4.1 Proposed Design

The design that the team is proposing will be a modified 12V childrens' car. The car will be modified to have two separate buttons that will sit on an armrest on either side of the child. The two buttons will be hooked up to the 12V motor, two 6V motors, and will serve as the main steering of the entire vehicle.

There will also be 4 light sensors that will be placed on all 4 directions of the vehicle which will serve as the kill switch in the event that the child gets too close to an obstacle. The vehicle will have a base build

that is similar to past GBG projects but differs in steering, adaptability, and kill switch option.

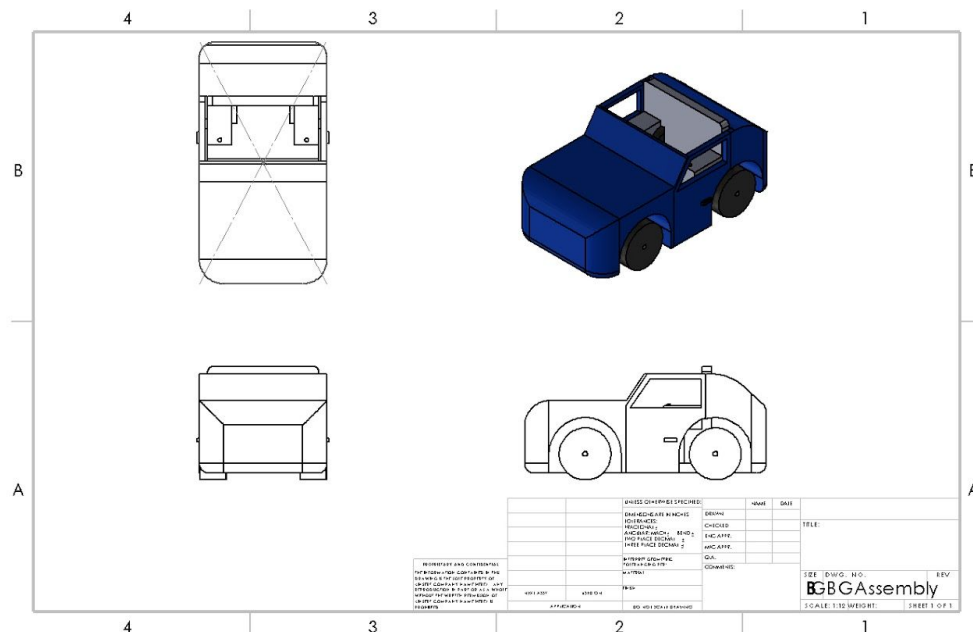

Figure 1: Two Button Car (created by Samuel Williams)

## 4.2 Main Body Analysis

The main body will need to satisfy the design as well as the CR's and ER's that were approved by Dr. Oman. To satisfy these criteria that vehicle must be easily accessible through local or online stores and must have a lifetime that is 3 years or more. The car must also be lightweight and must consist of a 12V motor, that is separated into two 6V motors. If the car does not meet all of these criteria then the car is not a viable material for this project.

### 4.2.1 Costzon Mercedes Benz R199 12V

The Costzon Mercedes Benz R199 12 V is rated for a single rider that is between the ages of 3 years and above [4]. The car can be purchased online at Amazon with a shipping time of 1-2 weeks and comes disassembled. It comes with a built in point harness and a 12 V motor that is separated into the back wheels of the vehicle. It is operated by a foot pedal accelerator and steering wheel.

The lifetime of the item is not specified but is estimated to be around 1-2 years as the age specification is rated for older children. Its weight specification is also not listed and therefore will be speculated to be around 60 lbs. as the car will need to support children 3 years and up. The lifetime of the item satisfies the lifetime criteria but is above the weight criteria. The item is a risky item for the proposed design as it has very little information.

The car itself is wide enough, 559mm, to modify the inside of the car to add armrest. With the addition of the armrest the age range will also change to a 1-3 years old, which is within the age range that the customers desired. Overall the car is not a terrible option but will be a risky choice.



*Figure 2: Mercedes Benz R199*

#### **4.2.2 12 V Ride on Car**

The 12 V ride on car is perfect for single riders starting at 18 months old to 6 years old. It is operated by a foot pedal accelerator and steering wheel [5]. The 12 V motor is separated into 2 separate 6V motor that is mounted to the back wheels with a speed option of high or low. The car itself is fairly lightweight only weighing 44 lbs. satisfying the weight limit of 50 lbs. The item can be purchased online through Amazon with a shipping time of 1-3 weeks which is within the material access criteria.

The lifetime of the item is not specified on the given specification from Amazon but through the comments of previous customers. It is estimated that the car itself has a lifetime of 3 years and if based on the age specification its lifetime is 5 years. Which is well within the lifetime criteria given in table 2.

Although the item satisfies all the given criteria the car itself does come with a few drawbacks. Through the comments from previous customers, the biggest problem with the car is that the battery is very sensitive to overcharging. Overcharging the battery seems to lower the vehicle's lifetime to a year at best. This vehicle's battery itself does not seem to be the problem but the fuse that starts the battery, which is an easily replaced component and therefore will not affect the item's lifetime of 3-5 years. Although the fuse will need to be replaced every year which is a small inconvenience to the parents.



*Figure 3: 12V Ride On*

### **4.3 Button Analysis**

The GBG club of Flagstaff is currently working on a different solution for the governing accelerator of the GBG vehicle. They are trying to implement the big dome button [6] which is much smaller than the previous button used. Unlike the previous solution this new button can be ran at 12V DC while the previous solution had a maximum operating voltage of 6V, due to the audio jack cable [7]. The proposed design will have two 6V motors that will be activated by a system of 2 buttons. The previous solution would work for this design but the size of the button does matter as a smaller button will have greater mounting options. As the design calls for two separate button on the armrest that will be mounted on either side of the child. The big dome button has a diameter of 60mm while the previous button has a diameter of about 180mm [8], the big dome button is about half the size of the previous solution. Both buttons are lightweight and can be purchased online at Amazon with a minimal shipping time of about 1-2 weeks. Although both buttons satisfy the CR's and ER's of this project the best choice for this design is the big dome button.

The lifetime for both buttons rest entirely on the wires that connect the button to the motors which are easily replaced and therefore is not a big concern for this project.



*Figure 4: Big Dome Button*



## 5 Conclusion

The button solution for the proposed design will be the big dome button as it will provide a wide range of mounting option. Rather than the previous button used in past GBG which was too big to mount anywhere else but the steering wheel and headrest of the vehicle. As for the main body of the design the best choice will be the 12 V ride on car as it provides a more detailed item specification and will have a more solid estimate on its lifetime.

## References

- [1] Matthew W. Brault, "School-Aged Children With Disabilities in U.S. Metropolitan Statistical Areas: 2010," in *www.census.gov*, 2011. [Online]. Accessed: Sep. 25, 2016.
- [2] NAU, "NAU welcomes GoBabyGo mobility program for children with disabilities," 2015. [Online]. Accessed: Sep. 15, 2016.
- [3] Northern Arizona University, "GoBabyGo Project Descriptions: ME 476C," Flagstaff, AZ, 2016.
- [4] Amazon, "Costzon Mercedes Benz R199 12V electric kids ride on car licensed MP3 RC remote control," in *Amazon.com: All*, Amazon, 1996. [Online]. Available: [https://www.amazon.com/Costzon-Mercedes-Electric-Licensed-Control/dp/B01IT8ZRV6/ref=sr\\_1\\_12?ie=UTF8&qid=1479343412&sr=8-12&keywords=12V+children+cars](https://www.amazon.com/Costzon-Mercedes-Electric-Licensed-Control/dp/B01IT8ZRV6/ref=sr_1_12?ie=UTF8&qid=1479343412&sr=8-12&keywords=12V+children+cars). Accessed: Nov. 10, 2016.
- [5] Amazon, "Best choice products kids 12V ride on car with MP3 electric battery power, red," in *Amazon.com: Toys & Games*, Amazon, 1996. [Online]. Available: [https://www.amazon.com/Best-Choice-Products-Electric-Battery/dp/B003Y7NQFC/ref=sr\\_1\\_5?s=toys-and-games&ie=UTF8&qid=1479497921&sr=1-5&keywords=12+V+%28+2+6V+motors%29+ride+on+toy](https://www.amazon.com/Best-Choice-Products-Electric-Battery/dp/B003Y7NQFC/ref=sr_1_5?s=toys-and-games&ie=UTF8&qid=1479497921&sr=1-5&keywords=12+V+%28+2+6V+motors%29+ride+on+toy). Accessed: Nov. 10, 2016.
- [6] Amazon, "Big dome push button - red," in *Amazon.com: All*, Amazon, 1996. [Online]. Available: [https://www.amazon.com/Big-Dome-Push-Button-Red/dp/B00CYGTH9I/ref=sr\\_1\\_3?ie=UTF8&qid=1479343310&sr=8-3&keywords=big+red+button](https://www.amazon.com/Big-Dome-Push-Button-Red/dp/B00CYGTH9I/ref=sr_1_3?ie=UTF8&qid=1479343310&sr=8-3&keywords=big+red+button) . Accessed: Nov. 10, 2016.
- [7] Amazon, "Battery Interrupter for adapted toys, size 'AA' or 'AAA'," in *Amazon.com: Office Products*, Amazon, 1996. [Online]. Available: [https://www.amazon.com/Battery-Interrupter-Adapted-Toys-Size/dp/B00B1P7600/ref=pd\\_bxgy\\_328\\_img\\_2?encoding=UTF8&pd\\_rd\\_i=B00B1P7600&pd\\_rd\\_r=ECC7MR40WGJQBFQKW290&pd\\_rd\\_w=Jvdo4&pd\\_rd\\_wg=MShcJ&pvc=1&refRID=ECC7MR40WGJQBFQKW290](https://www.amazon.com/Battery-Interrupter-Adapted-Toys-Size/dp/B00B1P7600/ref=pd_bxgy_328_img_2?encoding=UTF8&pd_rd_i=B00B1P7600&pd_rd_r=ECC7MR40WGJQBFQKW290&pd_rd_w=Jvdo4&pd_rd_wg=MShcJ&pvc=1&refRID=ECC7MR40WGJQBFQKW290). Accessed: Nov. 11, 2016.
- [8] Amazon, "AbleNet 5" big red twist switch," in *Amazon.com: All*, Amazon, 1996. [Online]. Available: [https://www.amazon.com/AbleNet-Big-Red-Twist-Switch/dp/B00CQCW1YI/ref=sr\\_1\\_4?ie=UTF8&qid=1479499288&sr=8-4&keywords=big+red+button](https://www.amazon.com/AbleNet-Big-Red-Twist-Switch/dp/B00CQCW1YI/ref=sr_1_4?ie=UTF8&qid=1479499288&sr=8-4&keywords=big+red+button). Accessed: Nov. 10, 2016.