

# Advanced SolidWorks course curriculum development

**By:**

Muhammad Alhajri

Naser Alhajri

Abdualziz Alajmi

Yousef Alhaddad

Mohammad Alfadhli

## **Project Group #F**

**Project Sponsor: NAU Mechanical Engineering Department**

**Faculty Advisor: Dr. Sarah Oman**

**Sponsor Mentor: Dr. Sarah Oman**

**Instructor: Dr. Sarah Oman**

*Submitted towards partial fulfillment of the requirements for  
**Mechanical Engineering Design I***

*“Senior Capstone Design”*

*August 7, 2017*



Department of Mechanical Engineering

Northern Arizona University

Flagstaff, AZ 86011

## **DISCLAIMER**

This report was prepared by students as part of a university course requirement. While considerable effort has been put into the project, it is not the work of licensed engineers and has not undergone the extensive verification that is common in the profession. The information, data, conclusions, and content of this report should not be relied on or utilized without thorough, independent testing and verification. University faculty members may have been associated with this project as advisors, sponsors, or course instructors, but as such they are not responsible for the accuracy of results or conclusions.

# EXECUTIVE SUMMARY

Considering the engineering graphics fundamentals, the course at NAU was able to meet its core objective. ME 180 resulted in students obtaining a basic understanding of engineering graphics. However, such students were unable to utilize the advanced features of SolidWorks and to draw advanced designs or systems by use of the hand. With the market demanding professionals in possession of advanced skills in engineering graphics, students who underwent ME 180 could not meet the market requirements. Some of the original course shortcomings included the lack of adequate drawing by hand to improve the students' skills and online classes to cater for the learners unable to attend physical meetings, in its design. Therefore, the NAU engineering department requested the TEAM to develop a course to follow ME 180 to equip the students with advanced engineering knowledge and skills that the market desired.

The project team, after a comprehensive research, created a course design building from the existing courses and adhering to the customer and engineering requirements, and assisted by the house of quality. Mainly, the course design was supposed to have five aspects, which are the project theme, time, homework, project, and lectures, that a student had to fulfill for them to be considered as having completed the course. Lectures were viewed as an avenue for the students to interact with the lecturers and acquire first-hand information regarding the course. Homework was supposed to help the student's practice skills acquired over the course. Also, the design was organized in a way to allow students use specially designed advanced SolidWorks tutorials to hone their abilities. Since the primary aim of the course was to enable students to develop advanced 3D models using a broad range of materials, the project theme was considered essential as it was supposed to assist students in practicing their abilities to create physical models, which was a fundamental course requirement. The aspect of time was considered essential to ensure that the time allocated for the course was adequate for the students to fulfill all the requirements. Finally, the exams were seen as a critical aspect of the course as they provided a measure of the students' proficiency.

After completion of the project, testing revealed that the selected course met most of the customer requirements apart from enabling the students to perform experiments and read scales. Therefore, some of the proposed improvement to the selected was to include lab sessions. Also, the number of videos was supposed to be increased to increase the course interactivity. Among the areas of improvement, there was adopting different teaching methods to enhance inclusivity.

## **ACKNOWLEDGEMENTS**

The team likes to express everyone who supported them on their project with greatness. Dr. Oman is the client and advisor to our team, we thank her on all of her supported tips to complete our project. She helped the team on creating the engineering requirements and providing more details on each section in the final report. Dr. Wade was helpful on commenting the customer requirements to be more specific for our project. Dr. Willey helped the team on choosing new topics for the lectures and provide us few ways to record video lectures. Finally, we thank mechanical engineering department on supporting the team in their project.

# TABLE OF CONTENTS

DISCLAIMER .....	i
EXECUTIVE SUMMARY .....	ii
ACKNOWLEDGEMENTS .....	iii
TABLE OF CONTENTS .....	iv
<b>1 BACKGROUND .....</b>	<b>1</b>
1.1 Introduction .....	1
1.2 Project Description .....	1
1.3 Original System .....	1
1.3.1 Original System Structure .....	2
1.3.2 Original System Operation .....	2
1.3.3 Original System Performance .....	2
1.3.4 Original System Deficiencies .....	2
<b>2 REQUIREMENTS .....</b>	<b>2</b>
2.1 Customer Requirements (CRs) .....	3
2.2 Engineering Requirements (ERs) .....	4
2.3 Design Links (DLs) .....	5
2.3.1 Design Link 1: Syllabus .....	5
2.3.2 Design Link 2: Pre-lecture quizzes .....	5
2.3.3 Design Link 3: Lectures .....	5
2.3.4 Design Link 4: Videos .....	5
2.3.5 Design Link 5: Homework .....	6
2.3.6 Design Link 6: Project .....	6
2.3.7 Design Link 7: Exam .....	6
2.4 House of Quality .....	6
<b>3 EXISTING DESIGNS .....</b>	<b>8</b>
3.1 Design Research .....	8
3.2 System Level .....	8
3.2.1 Existing Design #1: ME 105 from BSU .....	8
3.2.2 Existing Design #2: ME 186 from CSUN .....	9
3.2.3 Existing Design #3: ME 463 from NAU .....	9
3.3 Subsystem Level .....	10
3.3.1 Subsystem #1: Programs .....	10
3.3.1.1 Existing Design #1: Autodesk .....	10
3.3.1.2 Existing Design #2: AutoCAD .....	10
3.3.1.3 Existing Design #3: Catia .....	10
3.3.2 Subsystem #2: 3D Printing .....	11
3.3.2.1 Existing Design #1: Fortus 400MC .....	11
3.3.2.2 Existing Design #2: Maker Bot .....	11
3.3.2.3 Existing Design #3: Robo 3D R1 .....	11
3.3.3 Subsystem #3: Themes .....	11
3.3.3.1 Existing Design #1: Lego .....	11
3.3.3.2 Existing Design #2: Knex .....	11
3.3.3.3 Existing Design #3: Meccano .....	12
3.4 Work Breakdown Structure (WBS) .....	12
<b>4 DESIGNS CONSIDERED .....</b>	<b>12</b>
4.1 Ideas on Themes Project .....	12
4.1.1 Design #1: Lego .....	12
4.1.2 Design #2: Advanced Tutorials from SolidWorks .....	12
4.1.3 Design #3: Apply Real World Experiences .....	13

4.2	Ideas on Course Structures .....	13
4.2.1	Design #4: Syllabus A.....	13
4.2.2	Design #5: Syllabus B.....	13
4.2.3	Design #6: Syllabus C.....	13
4.3	Ideas on Outside Help.....	14
4.3.1	Design #7: TA Sessions.....	14
4.3.2	Design #8: Video Tutorials from Instructor .....	14
4.3.3	Design #9: Group Work .....	14
4.3.4	Design #10: Instructor Office Hours.....	14
4.3.5	Design #11: YouTube Videos.....	15
4.3.6	Design #12: Outside Help for 3D Sketching from Other Classes.....	15
5	DESIGN SELECTED.....	15
5.1	Rationale for Design Selection.....	15
5.2	Design Description .....	16
5.2.1	Time .....	16
5.2.2	Exams.....	20
5.2.3	Homework.....	22
5.2.4	Lecture .....	24
5.2.5	Project .....	26
6	PROPOSED DESIGN .....	29
6.1	Lectures .....	29
6.2	Homework .....	29
6.3	Project.....	29
6.4	Exam.....	30
7	Implementation.....	30
7.1	Analytical Analysis.....	31
7.1.1	Videos .....	31
7.1.2	Tutorials .....	32
7.2	Design Changes .....	32
7.2.1	Hardware review 1 .....	32
7.2.2	Hardware review 2 .....	32
8	TESTING.....	33
9	CONCLUSIONS .....	34
9.1	Contributors to Project Success.....	34
9.2	Opportunities/areas for improvement .....	35
10	REFERENCES .....	37
11	APPENDICES .....	39
11.1	Appendix A: Work Breakdown Structure (WBS).....	39
11.2	Appendix B: Exam.....	40
11.3	Appendix C: homework 9 .....	42
11.4	Appendix D: Lecture.....	43
11.5	Appendix E: Lecture Prototype.....	46
11.6	Appendix F: Homework Prototype .....	54
11.7	Appendix G: Project Prototype .....	55
11.8	Appendix H: Exam Prototype .....	56

# 1 BACKGROUND

In this section, we would introduce our project description. Then, the original system to our project and how it would help our project.

## 1.1 Introduction

The aim of the project was to design a new course of advanced SolidWorks. The objectives of the project were to come up with a course that will allow engineering students to do advanced engineering graphics using an available graphic software. At this stage, the student should have a basic understanding of engineering graphics and how to use computer-aided design. This new course will provide the student with advanced knowledge on design features and tools that will allow them to come up with more detailed and accurate engineering drawings using parametric computer aided design tools. This program is imperative for the engineering department and the university at large. The aim of the school is to produce competent students who can succeed in their various areas of specialization. This course is designed to allow engineering students to come up with advanced engineering graphics using parametric computer aided design software [4].

## 1.2 Project Description

The project for this class was to create a new course for advanced SolidWorks. The sponsor of the project wanted a new course created that built on SolidWorks. However, this was to be an advanced course allowing the student to learn about advanced aspects of SolidWorks. The course will focus on teaching the student advanced features, tools and techniques that enabled them to be more productive when using SolidWorks. This project description is the original description given by the sponsor. It aims to advance on several courses already available that introduce students to using parametric computer aided design software as well as SolidWorks software.

Our sponsor's directive about the project description is:

“The Mechanical Engineering Department at NAU is interested in creating a new course to follow ME 180: Introduction to SolidWorks. This newly developed course will expand on the harder features of SolidWorks such as rendering, animation, multibody features, advanced sweeping, equations, sketch blocks, assembly visualization, advanced drawings, etc. This project will require the team to become SolidWorks experts in these advanced skills through the use of SolidWorks built-in tutorials, but be able to create their tutorials and homework assignments.”

It will provide the student with the extra knowledge and skills needed to make them more efficient when using this software for their work. The final deliverable for this project will be a 16-week sophomore/junior level SolidWorks course. The course will outline all the course content for the 16-week program including tutorials, homework instructions, and assignments. The deliverable will also include a breakdown of the course into teaching, homework, quizzes, attendance, exams, and the final project.

## 1.3 Original System

The original system is the ME 180 (Engineering Graphics) course. It is one of the classes that were offered in Mechanical Engineering plan. The ME180 course consists of an introduction of the SolidWorks program and 2D, 3D sketches. SolidWorks program is one of the most important parametric computer aided and design software available in the market today. It has many features that allow a user to build, design, create, and print. These features make it more advanced than other programs available. ME 180 aims to teach the student the basic understanding of the fundamentals of graphical communication, computer aided design, drafting and parametric modeling.

### **1.3.1 Original System Structure**

ME 180 (Engineering Graphics) is a class that offers fundamentals of graphical communication including sketching, computer aided drafting, design and parametric modeling. The prerequisite for this course is MAT125 (Pre-Calculus) where some students should have qualified with a grade greater than equal to C. this will be a face-to-face instruction class with twice a weekly class each lasting 75 minutes. Typically, each week consists of one lecture, then one workday (the workday has little class instruction and more one-on-one help from the instructor and class aide).

### **1.3.2 Original System Operation**

The ME 180 course has two sessions weekly with a timeframe of 75 minutes each. The coursework included 12 homework assignments from the main instruction book and the teacher, which made an overall of 20% of the final grade. Fourteen class activities and nine online quizzes come up with another 20% of the final grade with three exams, the first two equal to 15% each and the final exam equals to 20% of the final grade. Class attendance and participation make up 10% of the final grade.

### **1.3.3 Original System Performance**

The objective of the original system was to provide students with fundamental knowledge of engineering graphics. It provided students with basic knowledge in parametric design, and computer aided drafting, design, and sketching. From these objectives, the system was successful. It was able to meet its aims. It resulted in students who were able to understand the basics of engineering graphics but was not professional enough to use SolidWorks advanced features and to draw advanced systems or designs by hand. However, the design of the course was acceptable to the students with clear workflow, which allowed the students to perform well in the course.

### **1.3.4 Original System Deficiencies**

The original design of the system had some deficiencies that prevented it from meeting certain market requirements. The original concept was basic in nature, which required that students were introduced to the fundamentals of engineering graphics. However, more professionals with advanced skills in engineering graphics were needed which resulted in the students who had completed the original course not being able to meet market demands. The employment market seeks graduates who could use advanced features of available programs and therefore produce drawings that are more sophisticated. The design of the class also had some problems with the lack of online classes being an issue for students unable to make the physical meetings. The design of the course also lacked sufficient drawing by hand which is an oversight as drawing by hand is necessary to improve the skills of the students.

## **2 REQUIREMENTS**

This subsection contains the customer, engineering requirements and house of quality that the project should be in a position to meet. These requirements will also help guide the project team when making appropriate selections regarding the best solution. The main reason for this observation is that the best possible solution should satisfy all the requirements. The house of quality table will organize our ideas and manage them.



## 2.1 Customer Requirements (CRs)

This section presents a detailed description of the customer requirements for NAU. Each customer requirement has been discussed and its importance to the students and institution.

- Ability to identify, formulate, and solve engineering problems

The customer, in this case, is the college students and requires that the course should be able to provide students with the necessary knowledge and skills. It ensures that they can identify engineering problems, formulate ideas, solutions, and develop real solutions to engineering problems. It will be beneficial in the real world where there are multiple challenges. This course should help a student to identify what are mostly engineering problems and be able to come up with solutions to the problems.

- Ability to design and conduct experiments, as well as to analyze and interpret data

When the students face real-life engineering problems, they should come up with solutions to the problems. In order to come up with practical solutions, the student should be able to test their solutions in experiments that mimic real world conditions. They must, therefore, be able to set up experiments, analyze, and interpret the data generated to tune their solutions to solve the problems identified.

- Ability to use the techniques, skills, and modern engineering tools necessary for engineering practice

In engineering, there are techniques, skills, and tools needed for practice. These help the engineer to achieve their full potential while working. The course is therefore intended to provide the student with the knowledge, techniques, skills, and ability to use engineering tools to achieve their full potential as an engineer.

- Use the solid modeling capabilities of a computer-aided design (CAD) package to generate a three-dimensional solid model.

One of the critical skills needed in this course is to provide the student with the knowledge to generate 3D solid models from computer aided design packages. It is vital, as most of the design work will involve the use of the software. However, the student needs to be able to reproduce the virtual model made using software into a solid physical model. This course seeks to provide the student with the knowledge and capabilities needed to ensure they can use CAD packages to produce physical models.

- Have a thorough understanding and be able to create engineering drawings

Engineering drawings are precise. They require drawing to scale because they represent real life objects. Therefore, it is imperative to understand their composition and the reasons behind the stringent requirements. This course aims to provide the student with a thorough understanding of engineering drawings and the ability to create them.

- Sketch freehand pictorials of three-dimensional objects

One of the most important skills an engineer should have is the ability to represent a problem on paper. In many cases, this requires that the engineer should be able to sketch a free hand drawing of something. These sketches are very important for an engineer as they provide a quick way of representing information that is useful in the engineering process. The course should, therefore, provide the student with the knowledge required to produce accurate free-hand pictorials.

- Read engineering scales and take driving dimensions from manufactured parts.

Scale is very important in engineering. This requires that an engineer is able to read scales and therefore relate the size of the model to the real-world item. This is one of the reasons why engineering drawings are drawn to scale and measurements indicated. This course should therefore provide a student with the knowledge required to read scales and derive measurements from manufactured parts.

## 2.2 Engineering Requirements (ERs)

The Advanced SolidWorks course has nine engineering requirements, which are in Table 1. In this section, we determined how each engineering requirements would relate to our project.

Table 1: Engineering Requirements

Engineering requirements
Three assignment based on 3D Drawing on paper
Eight assignments based on advanced features in SolidWorks
Three exams
Twelve pre lecture quizzes
Twelve lectures in the semester
Twelve class activity
Two themes for projects will be chosen by instructor and students
One extra credit will be chosen by instructor
Five outside class video tutorials

The first engineering requirement is that the class contains at least 3 assignments based on the 3D drawing on paper. It is explanatory 3D drawing will act as the base for the course. It will allow students to have the required knowledge on advanced engineering graphics, which mainly involves 3D drawing. The second engineering requirement is that the class contains at least 8 assignments based on advanced features in SolidWorks.

The course aims at enabling students to be able to use advanced features of engineering graphics. SolidWorks is the most appropriate program utilized in the field and being able to use its advanced features shows that the students have understood the course. The assignments on this course will ensure that progress can be tracked and performance assessed. The course should consist of at least three exams. The distribution of exams will allow student grading and offer an opportunity for students to identify their weak areas. The course should also consist of at least 12 quizzes. Quizzes are important in determining the progress of a student on a given task. It will help in their progression in the course. The course requires that there should be at least 12 lectures in the semester. It is crucial as it provides the instructor with the opportunity to offer instruction directly to the students. At least 12 class activity in the semester is also a requirement of the course. It provides the students an opportunity to practice what they have learned in the presence of tutors. It allows direct instruction and feedback on the more practical aspects of the course.

The course should also consist of at least 2 different themes. Different themes allow the students to be aware of various situations where the knowledge gained can be applied in the real world. It made learning more enjoyable and directed at real world problems. The course should also consist of at least 1 extra-credit homework assignments. It is imperative as they provide an opportunity for students who might have started slowly to catch up with the rest of the students and be able to complete the course successfully. The final engineering requirement is that the course should contain at least 5 outside class video tutorials. Outside of class, video tutorials are paramount as they show the students a real-life situation where the lessons they are learning are being applied. It provides motivation for the students and allows them to connect their theory and practical lessons with real world situations.

## **2.3 Design Links (DLs)**

The design meets the engineering requirements of at least nine quizzes. The main reason that it does is that the quizzes that the students will receive under this design will go towards contributing to the number of quizzes completed during the course. It will also meet the requirement of at least five and nine assignments based on 3D drawing and advanced features respectively, as well as, two extra credit homework in SolidWorks. The main reason that it meets these two engineering requirements is that the lecturer will provide assignments to students relating to the quizzes beforehand. The quizzes will also be part of the lectures hence will contribute towards meeting the six lectures proposed in the engineering requirements. Furthermore, the design also includes laboratory work, which meets the need for six labs in a semester. This design also includes examinations administered to the students; hence, it meets the need for at least three exams. The lecturer will also provide students with tutorials outside normal classroom hours. It will help meet the requirement for at least three outside class tutorials. Lastly, the design divides the content based on different emergent themes hence it meets the engineering requirement relating to having six different themes.

### **2.3.1 Design Link 1: Syllabus**

The syllabus contains what the student will read and how they will benefit from the content of this course. It also shows briefly how the grading will be done and how it will affect the student marks. It highlights the policy concerning attendance, academic integrity and dishonesty the issue of plagiarism and the consequences that come with engaging in such behaviors. These will help the student to understand the course outline and finally find comprehensive report regarding the course. The syllabus will contain seven quizzes that will assist the student in understanding this topic course in detail. There is also policy development that will guide the student on how they will conduct themselves. The syllabus will help in designing the course structure by analyzing and making it easier for the learners to understand.

### **2.3.2 Design Link 2: Pre-lecture quizzes**

Pre-lecture quizzes seek to enhance the understanding of the student in the class, as well as prepare them for a lecture. Before the class begins, the student already has an idea of what the lecturer expects him or her to have learned by the end of the special lecture. Pre-lecture quizzes will be designed to provide a link between a previous lecture and the current lecture. They will usually require the student to apply information learned in the previous class to understand the present class. The pre-lecture quizzes also provide a valuable guide for the student on what they should consider important in the reading material available for the current class. The quizzes will mainly point the students to the main requirements of the particular lecture and therefore the key points to be learned. Typically, they will require short answer questions that the student can quickly note as they go through the lecture or the associated reading material.

### **2.3.3 Design Link 3: Lectures**

This part will mainly focus on the lecture. It is the place where learners get information that will equip them to be expertise and professional in their field of interest. The focus here is to make sure what is being taught is more relevant to the student. It will cover advanced learning of SolidWorks. Elaborating more on 3D skills for example animation, foundering and weeping. In the end, the student will have learned something. The lecture will be more involving to the student to avoid boredom during class lessons. Finally, they will be assessed by what they have learned in class.

### **2.3.4 Design Link 4: Videos**

Another design link that can be used in the course is the use of video. The video is an excellent avenue for providing instruction. It allows the students to view the actual content of their studies in practice. The

video is preferred as it allows the lecturer to make demonstrations without having to set up all the equipment for the actual work done. For instance, a pre-recorded video of “water meter housing” can be shown to the students. It will contain all the steps required to make the housing, but the lecturer will not have to perform the work itself. It is a less expensive way of showing demonstrations to the students as opposed to actual lab experiments or projects. The use of these design links helps the student to understand the coursework better. Furthermore, the video provides an alternative way of instructing the student which away from lectures which can become monotonous and boring if not designed properly to use external design links.

### **2.3.5 Design Link 5: Homework**

The course will involve Advance solid works class (ME380). That will ensure students are well conversant with advanced techniques in using solid works and 3D drawing. The course is new, and it will act as a way of improving the current course on solid works. The course has incorporated 11 assignments for the student so that the instructor can be able to determine on the student progress in understanding the course. The original in which this course has been adopted from is engineering graphic also called ME 180. The course will deliver on the foundation and background of 2D and 3D drafts mostly used by engineers.

### **2.3.6 Design Link 6: Project**

In class, we will create an advanced solid work class (ME 380), that will be accompanied by some two projects and will be given to students to help them understand the syllabus more. The two projects will focus on the individual assignment, tutorials and class lecturers. With the aim of ensuring student, have knowledge and information that will prepare them to be expert and professional in the substantial works. Our team will further explain to student one of the project and how the structure should be.

### **2.3.7 Design Link 7: Exam**

The analysis will entail the examination of advanced solid works course. For one to be assessed, they will have done challenging test and some set of portfolio advancement. Evaluation will be done once a student is done with all units and will be recorded on the student's transcript. The assessment is done as a way of enhancing insufficiency and to advance the learner to another level. The examination will majorly focus on the current unit and mostly on SolidWorks field of mechanical engineering.

## **2.4 House of Quality**

The house of quality helped the team in determining the importance of the customer and engineering requirements needed in the design. It is mainly because from the table 2; the team could determine the full technical significance (ATI), relative functional importance (RTI), targets, and tolerances of each engineering and customer requirement. In the previous section, some customer and engineering requirements were identified. These requirements will find use in the development of the HoQ, which is in table 2. It will be added to the HoQ to determine their importance. It is achieved by assessing the relationship between the customers and engineering requirements. The HoQ is critical to the project since it determines the significance of the customer requirements as compared to the engineering requirements. Finally, the HOQ was critical to the team since it provided an overview of the requirements and their significance towards the final design. It was essential since it ensured that the final design selected met the customer and engineering requirements.

Table 2: House of Quality

<b>Customer Requirement</b>	<b>Weight</b>	<b>Engineering Requirement</b>	Three assignment based on 3D Drawing on paper	Eight assignments based on advanced features in SolidWorks	Three exams	Twelve pre lecture quizzes	Twelve lectures in the semester	Twelve class activity	Two themes for projects will be chosen by instructor and students	One extra credit will be chosen by instructor	Five outside class video tutorials
1. Ability to identify, formulate, and solve engineering problems	4		1	9	6	6	9	9	9	3	6
2. Ability to design and conduct experiments, as well as to analyze and interpret data	4		1	9	6	3	6	6	6	3	6
3. Ability to use the techniques, skills, and modern engineering tools necessary for engineering practice.	5		6	6	9	3	9	6	9	6	3
4. Use the solid modeling capabilities of a computer-aided design (CAD) package to generate three-dimensional solid model.	3		1	9	9	1	6	9	9	1	3
5. Have a thorough understanding and be able to create engineering drawings	3		9	3	6	3	6	6	6	3	6
6. Sketch free-hand pictorials of three-dimensional objects.	4		9	1	6	6	6	6	6	3	6
7. Read engineering scales and take driving dimensions from manufactured parts.	3		6	6	3	9	6	9	6	1	3
<b>Absolute Technical Importance (ATI)</b>			122	160	171	114	183	186	192	81	123
<b>Relative Technical Importance (RTI)</b>			7	5	4	8	3	2	1	9	6
<b>Target(s)</b>			4	9	4	13	13	10	4	3	6
<b>Tolerance(s)</b>			-/+ 1'	-/+ 2'	-/+ 1'	-/+ 2'	-/+ 2'	-/+ 2'	-/+ 2'	-/+ 2'	-/+ 2'

## **3 EXISTING DESIGNS**

This section examines the existing designs. It provides information relating to the research conducted to seek existing designs. In this case, three existing designs were considered (ME 105, ME 186, and ME 463). This section also presents the system-level description of the existing designs and their relationships with the requirements. The section also displays subsystem level descriptions for the existing designs. These include programs, 3D printing, and themes. Lastly, it shows the WBS of the new course.

### ***3.1 Design Research***

This project considered three existing course designs. ME 105 is a Mechanical graphics class in Boise state university. Students receive an introduction to drawing sketches and using the SolidWorks program. This class acts as a prerequisite for more advanced classes.

ME 186 (Computer aided design for mechanical engineering class) is offered at California State University at Northridge. This course introduces students to how to make parts, assembly, drawing sheet and 3D drawing. This class provides skills that are important in many advanced classes on the same subject.

Finally, ME 463 (Biomechanics) offered at Northern Arizona University is the last existing design. This class has been selected because it involves many SolidWorks. Specifically, it includes the creation of human bodywork, which will be designed in SolidWorks.

### ***3.2 System Level***

ME 186 (Computer Aided Design for Mechanical Engineers) is a course designed as an introduction to concepts in engineering graphics and their implementation with CAD parametric modeling tools. This course's design meets the requirements for the new system. The course design is designed in a manner that can meet the engineering requirements of the new course. For instance, it makes use of different exams, quizzes, projects, lab homework, and participation as all-important aspects to the final grade.

ME 105 is a class designed to introduce students to engineering design graphics theory and practice applied to manufactured products using hand drawing tools and SolidWorks CAD software. The course covers concepts required to transform a user from a novice level to the intermediate user of SolidWorks software. It is an alignment with the requirements for the new class.

ME 463 (Biomechanics) course is designed to provide students with an understanding of the mechanics and mathematical analysis of the musculoskeletal system, the materials used in orthopedic applications, and control system modeling of biological tissues for use in orthopedic devices. Most of this work will be achieved by the use of SolidWorks software at an advanced level and therefore meets one of the essential requirements for the course.

#### **3.2.1 Existing Design #1: ME 105 from BSU**

The system level existing design is directed towards introducing the students to a new dimension of graphic designing. The new design will rely on the use of SolidWorks during implementation. The students in the system level design will also use hand-drawing tools. The design relates to my requirements in the sense that, it will involve the application of technical skills and use of hand tools; it will, therefore, help improve manual abilities that will encourage technological innovation.

The key objectives for the system-level existing design are to introduce mechanical engineering students to engineering graphics by equipping them with the fundamental knowledge of graphical parametric modeling, design, communication, and computer-aided drafting.

ME 105 Engineering graphics, this course is to introduce students to engineering design graphics using hand drawing tools and SolidWorks. There is two lecture for this course that meets 75 minutes each week, and the prerequisites are math 170 (Calculus 1). Moreover, the syllabus of this course breaks down to attendance, design project, quizzes, in-class exams, and a final exam. The homework for this course will be assigned on the blackboard but is not required to turn in the homework, yet is necessary to understand the how to solve the problems because the quiz is going to be similar to it. The exams will consist of questions designed to test your knowledge of the material comprehensively. For the project, the student will create a 3D assembly, and on the last day of the semester, students are required to present the project to the instructor and save the project in his/her university account. The grading for this course is going to be ten percent of the attendance, twenty percent for the design project. For the quizzes, there are five quizzes each one 5 percent, so the total is twenty-five percent. For the exams, there are two in-class exams the total is twenty-five percent and twenty percent for the final exam.

The homework for this course is not required to submit it, which will make the student ignore the homework. Therefore, the homework has to be needed to do it so that the student will learn more from it to get a high score in the quizzes and exams in this course. Furthermore, the in-class assignment goes to the attendance grade. Also, it is required to buy a kit for the class to do the 3D sketches and measure the Lego parts to use it in SolidWorks for the dimension.

### **3.2.2 Existing Design #2: ME 186 from CSUN**

The system-level existing design is related to the requirements since it incorporates modern and more efficient ways of communicating engineering designs. It is also founded on the most recent developments in technology and design engineering. It is, therefore, a proper suit for inculcating skills that are aligned to the current demands in graphic engineering.

ME 186 Computer aided design for mechanical engineering, this course is to introduce to concepts in engineering graphics and their implementation with computer-aided design. This course has one lecture that meets for 210 minutes each week. The syllabus breaks down to lab homework, attendance, in-class quizzes, reverse engineering project, written exam, hands-on exam, final design project, final written exam, and final hands-on exam. The grading for this course for the lab homework, in-class quizzes, reverse engineering project, written exam, and the hands-on exam is ten percent. For the final design project, final written exam and the final hands-on exam is fifteen percent and five percent for the attendance.

This course has too many assignments for one lecture each week; there should be at least two lecture each week. Also, the exams should be two exams and final exam, one is written and two on SolidWorks. Moreover, for the project, the best thing is to combine the reverse engineering project and the final design project to one project for the course.

### **3.2.3 Existing Design #3: ME 463 from NAU**

The primary objective of this class will be to equip students with competency skills that reflect the current demands in biochemical engineering. ME 463 Biomechanical Engineering, this course is designed to provide students with an understanding of the mechanics and mathematical analysis of the musculoskeletal system, the materials used in orthopedic applications, and control system modeling of biological tissues for use in orthopedic devices. In addition, this course is two lecture 75 minutes each week with four prerequisites. The syllabus is homework and quizzes for fifteen percent, a design project

for ten percent, which includes SolidWorks on it, and three exams for seventy-five percent. There will be homework assignment every week. The quizzes will be one to two before each exam. The exams will be one in mid-semester and one before reading a week and the last one in the final week.

This course uses Top Hat that all class materials are in it, and it does not use Blackboard. The homework has a particular paper (engineering paper) and GIVEN-FIND-SOLUTION format. Additionally, all the quizzes are online on Top Hat.

### **3.3 Subsystem Level**

This section includes the subsystem level descriptions for the existing designs, which include programs, 3D printing, and themes. The three programs considered in this project are AutoDesk, AutoCAD, and Catia. Under 3D printing, the solutions selected are Fortus 400MC, MakerBot, and Robo 3D R1. Lastly, the themes considered are Lego, Knex, and Meccano.

#### **3.3.1 Subsystem #1: Programs**

The following existing design programs will be used in the implementation of the syllabus: AutoDesk, AutoCAD, and Catia. The programs are designed to improve the efficiency of engineering project planning, execution, and evaluation. The programs have also made a significant contribution to the ability of engineers to develop both diverse and complex designs.

##### **3.3.1.1 Existing Design #1: Autodesk**

Autodesk is a program that allows the design of complex models [5]. It has many advanced features and allows compatibility with other programs. The user interface is intuitive and easy to understand, making it suitable for engineers and architects to use with no help. It helps the team to benchmark since it is possible to determine whether it meets the customer or engineering requirements provided. Furthermore, it will assist in ensuring that the students are in a position to produce complex engineering designs.

##### **3.3.1.2 Existing Design #2: AutoCAD**

AutoCAD is a complex program that requires a lot of training to use and perfect. It has professional level tools and is difficult for many students to understand [9]. The program also has a problem with compatibility even with the most standard computer programs. The base views for the program are also very basic making the design of complex designs difficult. This subsystem is important to the team since it will assist the team in benchmarking by determining whether the existing design meets the needed customer and engineering requirements. This valuable tool allows students to improve their drawing and modeling skills, which are essential to the success of the project.

##### **3.3.1.3 Existing Design #3: Catia**

Catia is a professional level tool used to design a wide range of products. One of the major advantages of Catia is that it can model the item as well as its behavior in the real world making it easier to manipulate [2]. However, the program is highly advanced and requires a lot of training and learning to be able to use effectively. It helps the team to benchmark since it is possible to determine whether it meets the customer or engineering requirements provided. This tool will also assist the team in providing real-life experience to the students. It is mainly because it finds widespread practical use in engineering modeling and design.



### **3.3.2 Subsystem #2: 3D Printing**

3D printing is the use of special purpose printers to print three-dimensional objects from three-dimension measurements derived from computer software. The existing designs examined under this section are Fortus 400MC, MakerBot, and Robo 3D R1.

#### **3.3.2.1 Existing Design #1: Fortus 400MC**

It has exciting features that are compatible with most programs. However, better integration is needed by enhancing its features. It works well with other programs for 2D viewing but is hard to use with applications such as AutoDesk. It will, therefore, provide customers with a highly efficient interface unlike traditional programs [10]. It will help the team benchmark the system since it offers 3D printing solutions, which are an integral part of the engineering requirements for the project.

#### **3.3.2.2 Existing Design #2: Maker Bot**

It is an existing 3D solution that is compatible with most 3D graphics programs such as SolidWorks. However, it is proprietary which means that the level of integration is better suited for proprietary software owned by its owner [7]. It will help in benchmarking the system since it provides a 3D solution compatible with SolidWorks, which meets part of the project requirements. Although it has advanced features, it does not support much 3D software. It means that maximum utility for this system can only be obtained when using software provided by the manufacturer.

#### **3.3.2.3 Existing Design #3: Robo 3D R1**

This 3D printing solution offers compatibility with most of the available 3D graphics software. The company offers highly innovative 3D printers that provide plug and print options, as well as, allowing large build volumes [8]. The solutions provided by the company will be highly applicable in 3D printing. It makes it appropriate for benchmarking the systems since it offers and innovating 3D printing solution.

### **3.3.3 Subsystem #3: Themes**

The themes that will be used in the class are all based on construction sets designed to allow people to come up with three-dimensional models of real life objects. The themes selected are Lego, Knex, and Meccano. These three provide building block sets, which are critical to the construction of 3D models.

#### **3.3.3.1 Existing Design #1: Lego**

It provides building blocks that can be connected in multiple ways to come up with different three-dimensional models [6]. The use of various blocks in multiple combinations means that the number of possible models is limitless. It helps the team benchmark the systems since part of the customer requirements need to course to be structured around themes. Lego provides an excellent solution for building models. Lego bricks have been used in numerous projects. The different Lego kits offer options for various types that can be created. The interconnectivity of the different building blocks makes it possible for the user to recreate a model of almost anything in the physical world as long as the components are larger than a single Lego block. It is important as it will provide the students the much-needed skills in 3D modeling.

#### **3.3.3.2 Existing Design #2: Knex**

It provides building sets designed for different scientific projects that allow models of scientific objects to be created. The biggest problem is that the models are limited in number meaning that the numbers of

objects that can be modeled are limited [3]. The model will help achieve client design specifications more efficiently. It will also assist the project team benchmark the systems as part of the customer requirements need to course to be structured around themes.

### **3.3.3.3 Existing Design #3: Meccano**

It provides a set of color-coded building blocks that can be assembled to create intricate models. It allows for creativity by allowing builders bring their imaginations to life using the construction systems offered by the company. The company achieves this by providing building blocks that can find use in building models. It will help the project team benchmark the systems since part of the customer requirements need to course to be structured around themes. Despite the ease of use and color-coding, the number of options available with Meccano is limited. The products offer a limited set of building blocks that can only be used for specific types of models. It means that there would be a problem with the user if the design they would want to create cannot be accommodated by the building blocks available [14].

## **3.4 Work Breakdown Structure (WBS)**

The team developed a work breakdown structure (WBS) which is in Appendix A. It provides an overview of how the new course will be organized. It starts with the course outline, course materials, and course prerequisites and progresses systematically to the lowest level that will include individual tasks such as grading and TA sessions. The WBS provides an easy guide to determine how the work will flow in the new course and the people responsible for different tasks. It helped the team because it was possible to determine the course, materials, and pre-requisite classes needed for the Advanced SolidWorks class. It was critical towards the development of a solution meeting the laid-out requirements.

# **4 DESIGNS CONSIDERED**

In this section, a number of tools, programs, and a variety of user interfaces are described. It will also include the different kits that engineers and clients could use to analyze designs and the possible outcomes from projects depending on input from both engineers and client. Sources for insights and inquiry that could aid clients and engineers are also discussed. A description of the various merits and demerits associated with each is also included.

## **4.1 Ideas on Themes Project**

For this project, ideas on the themes it will be indicated on the new course that our team will structure like Lego, advanced tutorial from SolidWorks and apply real world experiences. Topic ideas will help the student to be more creative and smart.

### **4.1.1 Design #1: Lego**

Students can use Lego bricks in classrooms or as part of homework in building 3D models of different designs. The students could receive different Lego kits, and each kit can be used in multiple ways. It means that Lego kits can find use in creating a wide range of projects. The parts can be used in SolidWorks software and also be physically built using the kit. Lego kits are cheap and allow multiple designs to be used. Therefore, the institution can afford to provide each student with a Lego set.

### **4.1.2 Design #2: Advanced Tutorials from SolidWorks**

The students are going to use advanced tutorials from SolidWorks in the classroom to equip themselves with the skills taught. Furthermore, students will be required to review some of the advanced tutorials

outside the classroom as part of their homework. Advanced tutorial from SolidWorks can provide a lot of the instruction needed to use all the features of the software. However, it only provides instructions, and a person needs to practice and be guided through the more sophisticated features of the software. The advanced tutorial provides step by step instructions to use the advanced features of SolidWorks. However, if a student is unable to understand a problem, there can be a problem since they would not be in a position to interact with someone more knowledgeable.

### **4.1.3 Design #3: Apply Real World Experiences**

The students will be provided with problems relating to real-life examples as part of their assignments. They will be required to provide realistic solutions to the problems posed. Applying real world experiences is crucial for this situation as the course is designed to make students more productive in reality. However, replicating real world experiences can be difficult in the classroom especially for new students. It can more easily be achieved by providing the students with examples from industry that require the particular skill set they possess.

## **4.2 Ideas on Course Structures**

In our project, course structure will be the different types of a syllabus that the team creates like syllabus A, B, and C. It will help the student to finish the course with good grade and understanding.

### **4.2.1 Design #4: Syllabus A**

The first syllabus will be composed of Exams (60%), Quiz (5%), Homework (20%), Project (10%), and Attendance (5%). The syllabus consists of 4 exams, quizzes in each week out of 10 Q, homework will be in two part; first, 3D was drawing 5% and other SolidWorks 15%, one project, attendance.

Syllabus A concentrates mainly on the exam, which provides the biggest grading opportunity for the students. It can be a problem for the syllabus as this is a practical course and relying on exams can paint an inaccurate picture of the progress of students. However, if the exams concentrate on the most important aspects of the course, syllabus A can prove to be the best in examining these issues.

### **4.2.2 Design #5: Syllabus B**

The second syllabus will be composed of Exams (25%), Quiz (7%), Homework (50%), Project (15%), and Attendance (3%). It consists of 2 exams one 10% and the second 15%, quizzes in class 5% out of 10 and 2% online by a TopHat out of 5, homework 10% 3D drawing and 40% SolidWorks, project 15%, attendance 3%.

This syllabus mainly focuses on the homework bit, which provides the biggest percentage for grading. It can help students because homework is taking ways providing students opportunity for scoring highly. However, it can be inaccurate since homework can be assisted and would not paint the best picture of the progress of students. However, this syllabus is the most well rounded as it will cover every aspect of the course with the weight it deserves, including in exams, projects, and assignments.

### **4.2.3 Design #6: Syllabus C**

The third syllabus will be composed of Exams (30%), Quiz (15%), Homework (25%), Project (20%), and Attendance (10%). It consists of 3 exams each 10%, 10% quizzes in class out of 10 and 5% online out of 5, homework 20% SolidWorks and 5% 3d drawing, two projects each 10%, attendance 5% class activity and 5% top hat

It is the most evenly distributed syllabus with different aspects of the course contributing towards the final grade. The even distribution of grading makes this the most appropriate syllabus as it will test all the different dimensions of the course equally and has the potential of producing the most well rounded and therefore qualified students. However, there are some areas of the course that are considered to be more important than others. With the distribution of the syllabus, it can be difficult to correctly examine the proficiency of students in these aspects since they are best tested using exams and projects.

### **4.3 Ideas on Outside Help**

The project goal for our team is to make sure that the student gains more help and opportunity to understand the course, our focus is offering all the help outside and inside the class to meet all their needs to be professional.

#### **4.3.1 Design #7: TA Sessions**

Students will receive teaching assistance (TA) classes once every week. These courses will aim at ensuring that the students understand the contents of the course. TA sessions designed to help the students understand the course materials outside the class. It will include assistance in classwork and projects. Teaching assistant sessions are crucial as they provide the student an opportunity to interact with their instructors. They can allow for immediate feedback although they can be time-consuming.

#### **4.3.2 Design #8: Video Tutorials from Instructor**

The instructor will make videos and PowerPoint presentations. This material will be availed to the students as part of the tutorial aimed at ensuring students better understand the course content. It will contain the notes that he explains it to class with more details like showing how he did it step by step. It will help the students to understand the concept of the course. Teach the student new techniques for extra credit. Tutorials can provide the students with information to use the software and other resources for the course. However, they can be misleading or confusing for entry-level students.

#### **4.3.3 Design #9: Group Work**

Students will be required to form groups of between 4 to 6 students. The groups will be assigned assignments that they will submit for review. Students can help each other on homework but not copy their work, study exams, and quizzes together. Create new idea to apply it to SolidWorks. Group work is vital for students as it allows them to collaborate on ideas and build on their knowledge. Group work is also important in preparing students to work in teams, which is the reality of their jobs. However, group work can be time-consuming to organize.

#### **4.3.4 Design #10: Instructor Office Hours**

Students are allowed to use office hours in meeting instructors and asking questions relating to the content taught in class. They can also seek clarification, as well as, help regarding assignments. The instructor will be required to offer such students the assist the needy. Students can meet their instructor on office hours to help them with anything related to the course and make sure each student understand the course. The engineering department can assist any student on the course during office hours. It allows a student to identify their problem and seek assistance. It can be instrumental in addressing individual student problems.

### 4.3.5 Design #11: YouTube Videos

The instructor will find various videos on YouTube relating to the course content and make the links available to the students. In turn, students may also search and find videos on the platform that can help them learn new techniques in SolidWorks. YouTube can be an outside support resource. It is freely available and allows students to compare tips from different users of the same programs. However, the quality of material can be diverse, and students can end up using inappropriate material from the site. YouTube is mainly favored because it is available freely.

### 4.3.6 Design #12: Outside Help for 3D Sketching from Other Classes

Encouraging students to seek outside help for 3D sketching when they are having trouble would implement this. The use of outside help such as a separate 3D sketching class can be imperative. It would allow students who do not have the necessary knowledge to gain the knowledge without dragging the rest of the class behind. It is also important because it allows students to gain practical knowledge they will need in a new class independently. It means that students who have not had experience in 3D sketching can quickly join the new course.

## 5 DESIGN SELECTED

The design selected for the course is the option that is best able to fulfill both the customer requirements and engineering requirements for the course. There is different engineering, and customer requirements for the course and each of these requirements have a different weight that corresponds with their importance to the course. The best option selected is the one that can provide the best balance between all the requirements.

### 5.1 Rationale for Design Selection

The solution selected is the new course, Advanced Tutorial from SolidWorks. It has been achieved because the existing designs of solutions do not expressly meet both the customer and engineering needs of the new system. Pugh chart used in determining the best option contain six criteria. Each has a particular weight (percentage) that it contributes to the final score.

From the Pugh chart below the best design is design # 2 under themes, design # 6 under course structures, and design #9 under outside class help. These solutions had the highest number of positives in the chart. It implies that it is better than the baseline in each of the criteria they received a positive. However, it is important to note that even though the Pugh chart narrows each category down to one idea that only means team is focusing on those ideas now. However, the team will revisit the other ideas as the project progresses. It allows the team to not eliminate the other options for themes and outside help, but allows our team to determine how to create a theme (homework, exams, etc. that revolve around that theme) and how to develop outside help options.

Table 3: Pugh Chart

Ideas	Themes project			Course structures				Outside class help				
	1	2	3	4	5	6	7	8	9	10	11	12
Criteria \ Design #	1	2	3	4	5	6	7	8	9	10	11	12
More advanced work than ME 180	+	+	D	-	D	+	+	-	+	-	D	+
Hand drawing 3D skills on paper	-	-	A	-	A	+	+	-	+	-	A	+
Quizzes and tests on their ability on Solid Work	-	+	T	+	T	+	+	+	-	-	T	-
Use real world experiences and apply it in the course	-	+	U	-	U	-	-	-	+	-	U	-
Structure course around themes	+	+	M	-	M	-	+	+	-	-	M	-
Work in groups in some assignments inside and outside the class	-	+		+		+	+	-	+	-		-
Σ +	2	5		2		4	5	2	4	0		2
Σ -	4	1		4		2	1	4	2	6		4

## 5.2 Design Description

The design of the course will encompass five aspects. These are lectures, homework, project theme, exams, and time. For a student to be considered to have successfully undertaken the course, they will have to fulfill all the aspects of the course design. Each of the aspects of the course is designed to fulfill a particular function. Lectures are very relevant for the course. They will form the primary mode of providing instructions to the students. Students can get to interact with lecturers and get first-hand instruction on the various aspects of the course. Homework is also going to be very necessary for the course. Using the knowledge gained over the course, homework will provide the students an avenue to practice the skills they have learned. Students will be free to use specially designed tutorials on advanced SolidWorks to add to their skills. The project theme is another essential aspect of the course. The course aims to allow the students to be able to create advanced 3D models through a broad range of materials. The project theme will allow the student to be able to practice on their physical model creation abilities, which is a fundamental requirement of this course. Time is also a significant aspect of this course. Like any other activity, it takes time for a person to grasp and understand the basics before they can progress and become conversant with more advanced skills before they can finally be said to be fully proficient. The time needed for a student to become fully proficient will be determined, and a student will be required to have spent the minimum time specified before they can be considered to have completed the course. Finally, exams will provide a mode for determining the proficiency of the student on the coursework. The focus of the exam will contain animation features, rendering, and equation. The exam will itself consist of three parts which will be to provide something learned in the course, how to apply equations on the part and finally to do animations using the parts made.

### 5.2.1 Time

The time taken by any student on a course can depend on many factors. The two most important factors are the difficulty of the course and how intelligent the student is. Assuming time to be a random variable and targeting the problem of finding the time student will spend on the course using Bayesian approach.

The very simple model for time can be represented using the Bayesian network as follows:

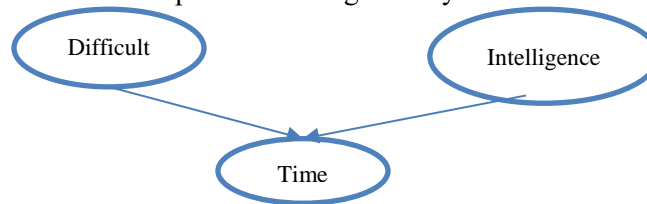

Figure 1: The Two Main Factors

In figure 1, the model difficulty of the course and intelligence of the student forms the parent for the time variable. Now in this simple model let us assume that all three random variables are discrete and take values, for instance, as:

$$\begin{aligned} \text{Difficulty: } D &\in \{d^0, d^1\}; \text{ where } d^0 = \text{easy course}, d^1 = \text{hard course} \\ \text{Intelligence: } I &\in \{i^0, i^1\}; \text{ where } i^0 = \text{low intelligence and } i^1 = \text{high intelligence} \\ \text{Time: } T &\in \{t^0, t^1, t^2\}; \text{ where } t^0 = \text{high}, t^1 = \text{medium}, t^2 = \text{low} \end{aligned}$$

The difficulty variable is representing how difficult the courses are, although Intelligence variable represents in general how talented the students are in the university. Later on, using observation, we will make it more accurate to a particular course and individual student.

The parameters for the above model can be learned from the previous data available and assuming that after learning all the parameters, we come across the following probabilistic distribution for our three

random variables.

In Table 4, we assumed the random variables for difficulty are 0.6 for an easy course and 0.4 for a hard course.

Table 4: Difficulty Random Variables

P(D)	$d^0$	0.6
	$d^1$	0.4

In Table 5, we assumed the random variables for intelligence are 0.7 for low intelligence and 0.3 for high intelligence.

Table 5: Intelligence Random Variables

P(I)	$i^0$	0.7
	$i^1$	0.3

In Table 6, shows three different columns for time, which are a high amount of hours, medium and small. It is compared with two variables intelligence and difficulty. The numbers in Table 3 are assumptions.

Table 6: Time Random Variables

P(T D, I)		$t^0$	$t^1$	$t^2$
	$i^0, d^0$	0.3	0.4	0.3
	$i^0, d^1$	0.7	0.25	0.05
	$i^1, d^0$	0.02	0.08	0.9
	$i^1, d^1$	0.2	0.3	0.5

Now knowing the difficulty of the course and the intelligence of a student one can easily find the probability distribution of the time that student will spend on the course. For instance, for an intelligent student ( $i^1$ ) and an easy course ( $d^0$ ), there is 90% probability that the student will spend low time on the course. It is just assumed a value of parameters.

Difficulty variable so far defines a probability of any course being difficult or not. We want to have a better understanding the highlighted course. One way of doing that is letting the TA (one or more) to solve the homework, quizzes, tutorials, lectures, labs, project and exams before the student. Based on their performance in the course with apparent difficulty, we can tell how challenging the highlighted course is or in other words using the TA's performance as an observation. We can have a better distribution of the difficulty by using Bayes' rule. The intelligence of a particular student can be checked based on their performance on the SAT. Now, we can add these two discussed variables in our simple model as:

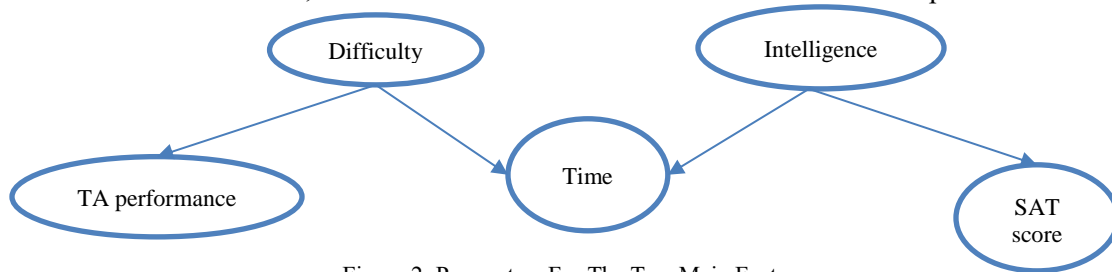

Figure 2: Parameters For The Two Main Factors

The TA performance is added as a child to the difficulty of the course, and not as its parent because difficulty variable will affect the performance of teaching assistant (TA) but not the other way around. However, the TA's performance can be used to infer about the difficulty of course as explained before.

The same explanation applies to why the SAT score was added as a child to the intelligence. The parameters for the two new random variables can be again learned for data and suppose that we come up with the following distributions.

In Table 7, in a bad score ( $s_0$ ) we assumed 0.95 with low intelligence and 0.2 with high intelligence. In good score ( $s_1$ ), we assumed 0.05 with low intelligence and 0.8 with high intelligence.

Table 7: Random Variables For SAT Score With Intelligence

$P(S I)$		$s^0$ : bad score	$s^1$ : good score
	$i^0$		0.95
$i^1$		0.2	0.8

In Table 8, in bad performance ( $ta_0$ ) we assumed 0.1 with an easy course and 0.3 with the hard course. In good performance ( $ta_1$ ), we assumed 0.9 with an easy course and 0.7 with the hard course.

Table 8: Random Variables For TA Performance With Difficulty

$P(TA D)$		$ta^0$ : bad performance	$ta^1$ : good performance
	$d^0$		0.1
$d^1$		0.3	0.7

Suppose that after the TA had performed the task of the course, the overall performance of the TA was bad, so using the Bayes' rule, we can infer about the difficulty variable as follows:

$$P(d|ta^0) = \frac{P(ta^0|d)P(d)}{\sum_d P(ta^0|d)P(d)}$$

Using the above distribution table:

$$P(d^0|s^0) = \frac{P(ta^0|d^0)P(d^0)}{P(ta^0|d^0)P(d^0) + P(ta^0|d^1)P(d^1)} = \frac{0.1 \times 0.6}{0.1 \times 0.6 + 0.3 \times 0.4}$$

$$P(d^1|s^0) = \frac{P(ta^0|d^1)P(d^1)}{P(ta^0|d^0)P(d^0) + P(ta^0|d^1)P(d^1)} = \frac{0.3 \times 0.4}{0.1 \times 0.6 + 0.3 \times 0.4}$$

$$P(d^0|ta^0) = \frac{1}{3}$$

$$P(d^1|ta^0) = \frac{2}{3}$$

As the intuition said that if the performance of the TA is bad, a probability that the course is difficult increases, in our case from 40% to 66.66%.

The question of who we learn the parameters from the data remains. There is a whole class of algorithm that does parameter learning in directed (our case) and undirected graphs. If we use maximum likelihood, we receive the following:

$$\tilde{P}_I(i) = \frac{1}{n} \sum_{i=1}^n \mathbf{1}\{I = i\} = \text{probability that variable } I \text{ takes value } i$$

Where  $n$  represents the number of data points,  $\mathbf{one}$  is the indicator function. The above formula that can be derived using maximum likelihood is nothing but the empirical distribution of variable  $I$  (intelligence). Similarly,



$$\begin{aligned}\widehat{P}_D(d) &= \frac{1}{n} \sum_{i=1}^n \mathbf{1}\{D = d\} \\ \widehat{P}_{TA|D}(ta|d) &= \frac{\sum_{i=1}^n \mathbf{1}\{TA = ta \text{ and } D = d\}}{\sum_{i=1}^n \mathbf{1}\{D = d\}} \\ \widehat{P}_{S|I}(s|i) &= \frac{\sum_{i=1}^n \mathbf{1}\{S = s \text{ and } I = i\}}{\sum_{i=1}^n \mathbf{1}\{I = i\}} \\ \widehat{P}_{T|D,I}(t|d,i) &= \frac{\sum_{i=1}^n \mathbf{1}\{T = t \text{ and } D = d \text{ and } I = i\}}{\sum_{i=1}^n \mathbf{1}\{D = d \text{ and } I = i\}}\end{aligned}$$

Using the above relation, one can find all the parameter of distribution for all five variables.

The discussion so far was based on the assumption that all the variables are discrete but the methodology used to infer about the time taken by any student in a course is not restricted to just discrete random variables, one can easily extend it to continuous random variables. Again, the choice of whether to have a discrete or continuous random variable is entirely situational. For instance, continuous random variable for SAT score makes no sense; you cannot have a score in decimal. One can think of assuming time to be a continuous random variable, but we may not be interested in finding the exact second to which the time was spend on a course. That simplifies the problem, and one can assume the time to be discrete variable, and change the bin size for the empirical distribution based on the how little (in seconds, in hours, in days) answer is required.

The model used for making the inference on time variable can be further extended to multiple students, to multiple courses and even to various universities at a time. One way of doing that is by using the plate dependency model such as:

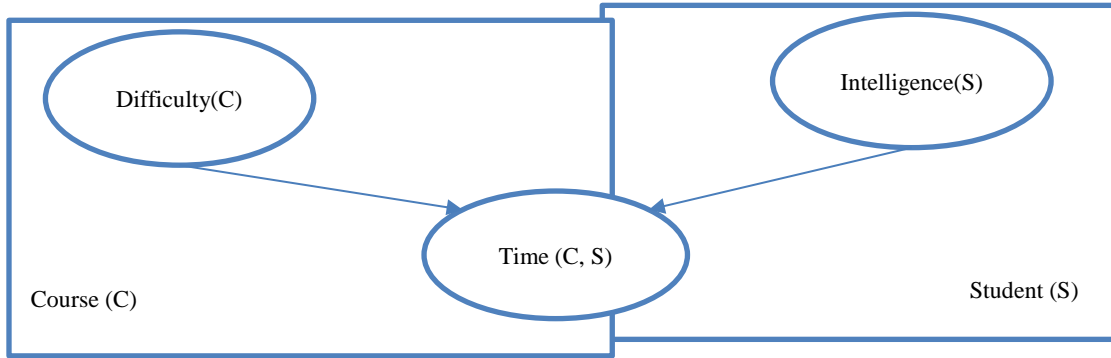

Figure 3: Model The Two Main Factors

The model can be unrolled (ground network) and then one can make inference over the time variable. In the above model, there are only three random variables used instead of five, but the probability distribution of the intelligence and difficulty has already been modified based on the TA's performance and SAT score of the student (an example was shown under "observations" above). The random variable 0.1 for the TA's bad performance with the easy course will the probability be  $\frac{1}{3}$ . When the random variable 0.3 for the TA's bad performance with the hard course, the probability be  $\frac{2}{3}$ . In the ground network, the exact inference may become expensive computationally, and one has to really on approximate inference methods such as message-passing algorithm (exact in our case – tree structure) or sampling methods such as Monte Carlo Markov Chain (MCMC) method.

## 5.2.2 Exams

Challenge examinations and set portfolio development make up the primary methods of evaluation. Success in the assessment outcomes is an official unit achievement and is recorded on the learner's transcript. This assessment helps in improving academic deficiencies, grades or aid admission into another level. This paper analytically analyses the evaluation of an introduced unit on advanced SolidWorks in the field of mechanical engineering. The examination syllabus encompasses; Main Examination (30%), Quizzes (15%), Assignments (25%), Project (20%), and Class attendance (10%). It comprises three exams each 10%, seven in-class quizzes total of (15%), Assignments 20% SolidWorks and 5% 3D drawing, completion of two projects each having weight of 10%, class attendance 5%, lesson activity and 5% goes to top hat platforms. It is the most regularly distributed syllabus with different aspects of the course contributing towards the final grade to allow the student graduate from senior upper class.

The even grading distribution makes the format the most appropriate curriculum since, owing to these different dimensions of the unit equally could be covered equally. In Appendix B, there is an example of this exam. It is important considering cross-sectorial nature of work that is performed by mechanical engineers. However, some areas of SolidWorks study are regarded as more important than others. With the scattering of the outline of the course, it may seem difficult to examine student's proficiency efficiently and correctly as shown in Table 9, since they are adequately and thoroughly tested by the series of exams and evaluative SolidWorks projects.

Table 9: Rubric Used to Evaluate an Exam Paper on Advanced SolidWorks

Items	Criteria			
	4	3	2	1
Views (×5)	All views required retrieved and represented completely. All lines (hidden or centerline) are accurate.	All necessary views are represented by at least one item always.	All views are available but incomplete and Lines are missed.	Views are not complete.
Layout	Placed and aligned all views by use of orthographic projection. Proper scaling as well as similar spaces between views and borders.	Alignment by orthographic projection, acceptable spacing whether the scale is large or too small.	Aligned by the help of orthographic projection but the spacing is unequal as well as irregular scale.	Some views not aligned and a faulty scale.
Detailing	Elaborated and appropriate dimensions. An object can be designed based on the dimensions.	One or two dimensions not indicated, but can still navigate the model producing some interpretation.	More than two dimensions are missed, and the object requires more data to create.	Insufficient dimensions and cannot build an object.
Title	Placed appropriately and all necessary features included.	Appropriate placement but has a single piece of missing information.	Well---placed but at least two components are missed.	Missing or has no information included.
Presentation	Drawing is well--presented and easy interpretation.	Drawings are neatly presented and minimal difficulty in interpretation.	Difficulty in interpreting the Drawing.	Cluttered drawing as well as difficulty in interpretation.

The exams will be graded using the above rubric with every item rated out of five targets; the final score

is multiplied with the criteria the work presented by the student reflect. The results are then graded with the highest-ranking score being and the least being F, as shown in Table 10.

Table 10: Grading System

Grade	Mark %
A	90 to 100
B	80 to 89
C	70 to 79
D	60 to 69
F	0 to 60

It is vitally necessary to test learners on the content they learned and understanding of the practical aspects. The focus of the reviews is to offer students with advanced and useful questions on animation features, mathematical equations, and rounding. Every exam comprises three parts. The first section covers the general knowledge acquired in the course. The part two is related to the application of the equations. Third, the final paper, which is a take home, tests the knowledge of the animation of the part they designed. The first exam will be set from the first five chapters of the course outline. They give an introduction for the learner into knowledge and expertise covered in SolidWorks study. It tests on the introduction to 3D sketching, advanced modeling, sweep with composite curves and finally on advanced modeling with sweep and loft. The exam earns 10% marks if the project meets full requirements of object design and creation. The administration of the exam is in the fourth week immediately after learning the concepts in chapter four.

The second test that students are required to pass upon clearing the study of chapter eleven. It is related to learning of loft with guide curves, surfaces-advanced modeling, advanced surface offset surface, and ruled surface, surfaces vs. solid modeling, and sheet metal parts. The exam administered on the eighth week covers knowledge of designing surfaces widely. The paper involves mathematical calculations and equations guide curves. An equation forms a relationship among model dimensions using the dimension names that is dimension name@feature name. Apart from mathematical functions like -,\*, +, and /, one can also apply the constant value of pi and other functions within like the following equations: sin (a),cos (a), tan (a), atn (a),abs (a), exp (n),log (a), sqr (a), int (a), and sgn (a). It also contributes 10%, and students acquire marks out of the maximum based on the evaluation of the equations and surfaces created.

The final and the third exam also accounts for 10% of the grade, but it covers the last section of the unit, which practically deals with animating an object using the dimensions the student obtained. This test is essential in evaluating the practical knowledge and skills in SolidWorks. The chapters examined include sheet metal conversions, creating a core and cavity-linear parting lines, and top-down assembly. It is set to be done the last week of the semester. It portrays the student's efficiency in engineering design projects. On top of that, test the knowledge of the competence in computer aided design software such as AutoCAD. This paper also tests concepts of physical, numerical, and computational modeling of moving parts of the mechanical device designed in the project. The final paper should meet the standard required to earn maximum marks.

The model example is going to be the third exam, which will be taken at home. The exam is attached to this report along with SolidWorks parts and assembly.

This program equips students with specialized knowledge and research techniques for the advanced projects in their selected area of study, which is SolidWorks. This program also requires a learner to comprehensively accomplish an engineering project or thesis that demonstrates their ability to perform an independent investigation. Thus, this condition adds a high concrete value into a student's final work and

results. Capacity to perform mechanical engineering analysis develops and implements designs and solutions. Comprehension of the different mechanical and non-technical aspects that affect the feasibility and application of SolidWorks design projects is attained by the efficient study of the outline and regular practice. The basis needed to support engineering decision-making through professional practice, and effectively categorize, consider and account for many objectives [15].

The comprehensive examination tests the student's knowledge in his/her fields of coursework focusing on information concerning the project's design and independent study. The analysis provides a clear structure of the exam, the grading system, and the marking instructions that facilitate the evaluation process to give reliable results. The results of a student who has completed the course should reflect the attention and intellectual effort made by the learner.

### 5.2.3 Homework

The structure of the 11 homework will be three done by hand and eight done in SolidWorks. The eight home works will be based on three from the book which the student needs to use the same features that are in the book and apply it, the other three it will be from the instructor which contain sketches, dimensions and part with advance features, tools, and the student will do it as a homework. The last two homework it will be from the tutorial that is in SolidWorks.

#### Homework 1

The first homework is about modeling 3D. In modeling, 3D students are expected to draw sketches on the papers using geometrical shapes. This assignment is aimed at increasing the creativity and efficiency of students who use solid works and would wish to be experts in the same field.

Homework 1( 100 marks):

Use grid paper to draw a multi-view drawing of the shape shown below following all drawing conventions.

- 1- You must correctly draw the 3 primary views in the proper orientation to each other third angle projection. Front, right and left view should be well arranged. (10 marks)
- 2- Scale the pbject such that it substantially fills your sheet pf grid paper ( two or three page, three drawing). The scale below is 1 grid=0.25 in. ( 60 marks)
- 3- You must show hidden lines, centerlines and center marks if necessary for all your views.(15 marks)
- 4- Label all appropriate views, dimensions, names, and scale with uppercase gothic. (15 marks)

Figure 4: Homework 1 Questions

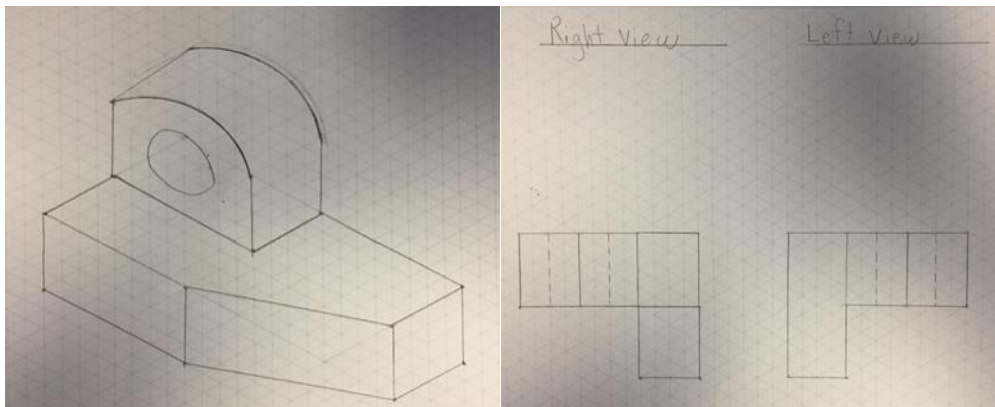

Figure 5: 3D-Sketches on Paper

**Homework 2**

The second homework will be a review of SolidWorks. This review will mainly encompass the topics that were learned in Engineering Graphics ME 180. A review of previous work taught is vital for the practical understanding of the new techniques and skills that will be taught in advanced solid works.

**Homework 3**

The third homework will be about sweep with composite curves. In this assignment, students will be expected to do a sketch and incorporate the application of composite curves. It is because the sweep path and guide curves are important because they control the shape and behavior of the sketches for example twisting.

**Homework 4**

The fourth homework will be about advanced modeling with sweep and loft. The students will be expected to come up with graphic sketches using the features of sweep and loft that they have learned from the week's tutorial. The tutorial will encompass the set of rules to be considered while developing a sweep feature and necessary requirements for a loft feature.

**Homework 5**

The fifth homework will be about advanced sketches and 3D. Advanced modeling uses techniques from other fields such as art in developing the advanced graphics. The advanced graphic technique will enable students to begin specializing in SolidWorks to become experts.

**Homework 6**

The sixth homework will examine the students about their knowledge of using surfaces. Advanced modeling uses surfaces to create geometry used in the development of solid features. Students should be able to manipulate surfaces to come up with solid features. Unlike solid features, surfaces can be trimmed, moved, rotated or copied while developing solid features.

**Homework 7**

The seventh homework will examine the knowledge of the students in the solid work program under section surfaces. Section surfaces can be either offset surfaces or ruled surfaces. Students should be in a position to distinguish between the two types of surfaces and use that knowledge in the development of SolidWorks features.

**Homework 8**

The eighth homework will encompass the knowledge from both surfaces and solid modeling. Students will be expected to distinguish between the two types of modeling. In so doing, the students will create models, modify the models created and lastly use the features in SolidWorks development.

**Homework 9**

The ninth homework will access the knowledge of the students on developing sketches. Sketches are used in designing sheet metal parts. In Appendix C, there is an example of this homework. Advanced solid works, therefore, encompasses the application of sketches and flanges which students should be well conversant with after attending the course's tutorials.

**Homework 10**

The tenth homework will examine the knowledge of sheet metal parts. After creating sketches, students will be expected to understand the parts of metal that will be developed from the sketches created. There are four vital parts of a metal including the base and edge flanges, sketch bends, and cuts.

## Homework 11

The last homework will encompass the knowledge on top down assembly. Students will be expected to portray the skills and techniques learned from advanced SolidWorks in increasing the quality of output designs and the time spent in creating the features. Top down assembly will be the final chapter, and it will examine the ability of the students to edit solid work features using the advanced skills and techniques learned in this course for the best quality of solid work features.

### Grading rubric:

Homework 25%

Three Modeling sketches 5%, each 1.67%

Eight SolidWorks Modeling 20%, each 2.5%

## 5.2.4 Lecture

The focus of this section will be lectures, which is the place that the students get to learn and get all the information that they need to be an expert and professional in the class. Our focus for the lecture is to make sure it is useful enough for the student to gain all the material that we will provide. Like explaining the advanced tutorials in Solid Works, explaining how to do 3D skills on papers and lecturing the advanced features in Solid Work for example animation, rendering, and sweep. It will make the lecture attractive to the student in a way that will not make them boring and sleepy. Give them activity question to catch up the lecture.

The first lecturer will be on the introduction of solid work and act as a tutorial, to guide the student through the knowledge of Solid. In the introduction segment, this lecture will major on the definition of solid work and solid work basics. In Appendix D, there is an example of lecture slides. SolidWorks is defined as a complete three-dimensional design solution that integrates a large number of advanced features to facilitate the modeling of parts, create large assemblies, and generate drawings and other functionalities that allow someone to validate, manage and communicate projects quickly, accurately and reliably. SolidWorks Basics teaches you how to use SolidWorks mechanical design automation software to build parametric parts and assemblies models and to make drawings of those parts and assemblies.

The second important thing after definition, which still falls under the first lecture, will be on the features of solid works and definition of the basic parameters. On the features of solid work, the following will be discussed. Its natural environment and easy-to-use design tools characterize SolidWorks. All integrated into a single design program with more than 45 complementary applications to facilitate the development of your projects. The feature that makes Solid Works a competitive, agile, and versatile tool is its ability to be parametric, variation, and associative, as well as using smart geometric functions and using a feature manager to view, edit, delete and Update any one-way operation bidirectional between all associated documents. Looking at the definition of key parameters the following will be established. The key parameters are dimensions (dimensions) and Geometric Relationships that define a three-dimensional model. Solid Works associates to each of the dimensions of a sketch as well as to the three-dimensional operations a name that allows modifying it at any moment and its update in the rest of associated documents. Moreover, solid works contain three modules: Part, Assembly, and Drawing. The creation of paper in each of them generates a file with different extension. The documents, although not observable, are associated and linked to each other.

The next lecture will be on the 3D sketch. Under this lecture, the following will be established. With the advancement of CAD/CAM innovation, 3D element demonstrating and virtual model innovation have been utilized as a part of mechanical outline and assembling. In this paper, given Solid Works programming, three-dimensional model of a single surface layered machine was built up, and the entire moving procedure was reenacted, which gives premise to the static and element quality examination look into on single surface folded machine and has critical hypothetical importance and viable application esteem. In this paper, given Solid Works programming, 3D element displaying and virtual amassing on

the single-layering machine were completed, the development procedure was reproduced, which made an establishment for the single creasing machine's further dynamic quality examination and improvement plan. This exploration means can beat real model's inadequacies extremely well, for example, long advancement cycle, extraordinary cost reduction, and small design were productive.

To make a 3D sketch pick the 3D Sketch catch from the Sketch toolbar or select Insert. 3D Sketch from the menu bar. When you choose this choice, the 3D drawing condition is summoned, and the birthplace is shown in red shading. For making a 3D draw, you do not have to choose a portraying plane. When you summon the 3D drawing condition a portion of the portraying, apparatuses are enacted in the Sketch Tools toolbar. You can utilize just a portion of the outlining devices in the 3D portraying state. The drawing instruments that can be utilized as a part of the 3D portraying condition are talked about next. Keeping in mind the end goal to make a 3D PC movement, it is not a simple errand. It requires extensive information and specialized support. It is prescribed that the masters are skilled in making vivified PC design. The computer is additionally ready to make a 3D sketch. To build up this 3D sketch it requires innovatively propelled workstations fueled costly. There are a few sorts of working frameworks like Microsoft Windows, Mac OS X, and Linux, which is the most generally utilized. Other gear, for example, movement catch, video capture execution, and blue screens are additionally used to accomplish flawlessness. 3D innovation is once of PC representation engineers talented and recreations utilizing top of the line programming and machine.

To make 3D and render the perplexing blend hues, virtual lighting, and surfaces, workstation required powerful handling force and memory to make figures seem three-dimensional. Since 3D innovation has made considerable progress, it is expanding in the execution yet diminishing in cost. PCs are more affordable and even more effective in the pass and can deal with better for 3D. The path individuals to utilize 3D have started spread from diversions to such exercises as a corporate introduction, web and item plan and personal amusement. PC producer has put 3D increasing speed and many sorts of 3D innovation into their whole PC that helpful for design and engineering application. This innovation is potential growing quicker than other desktop registering area.

Solid works, works separately creating mechanical parts (3D). This process generates one file per piece. In the assembly module, we can build our mechanical assemblies, arranging each piece in its place. It is then easy to generate manufacturing drawings. In short, it is ideal to start in the world of 3D industrial design allowing, in record time, to have prototype models. Logically it is recommended to have knowledge of technical drawing and according to the cases of mechanics. The primary operative of the program is the initial design of 3D parts; the files are saved and later assembled into a new file.

Advanced tutorials in Solid Work lecture will be our next point of discussion in this course. In this lecture, the following things should be noted. The first release of Solid Works was in 1995 new releases have been released almost every year. Solid Works 2014 is 3D CAD modeling software that is very intuitive and simplified compared to its counterparts. It is available for free Windows operating system. Although it looks like a recent alternative to market standards like AutoCAD, it has been running since 1995. It is ideal for essentially designing products in a very short time. Its learning curve is lower than other mechanical design programs. If you have an idea, you can quickly translate it into a design with Solid Works. Solid Works 2016 helps one take care of the plan issues.

Advanced modeling lecture will be categorized into two namely; Sweep with Curves and advanced modeling with sweep & loft. In the sweep with curve lesson, the following important paradigms will be established. With the Sweep include, you can make a shape by moving a 2D portray profile along with a 2D or 3D outline Path. The breadth utilizing guide bends is the most important alternative in the Advanced Modeling instruments. In this range highlight, the segment of the breadth profile fluctuates as indicated by the guide bends along the compass way. To make this kind of highlight, you have to make the portray of the profile, way, and the guide bends. Sweep connection must be connected between the guide bends and the profile of the breadth include. Sweep connection permits the profile to change shape

and size along the breadth way.

In the sweep & loft lecture, the following points will be noted. A sweep is best when you have one uniform cross-area. Great case of this is the spring. Space is best when you have a body with various cross segments with various geometries. A sweep makes a strong with uniform cross Section. A sweep element requires two outlines a profile and away. These two portrayals cannot lie on a similar plane or be parallel. The way can be either open or shut profile. It could lie in one plane or lie on various planes (3D draw). On the other hand, a loft creates a strong with many cross-areas; different ways could be utilized. Loft charge makes a surface or a strong by clearing and mixing using at least two unique profiles.

The final lecture will be on multi-body solids, and the following important points will be deliberated. A multi-body part is a top down work process, which permits you to make and position different bodies inside a single part archive. This procedure is particularly helpful for outlining plastic parts. A top-down work process dispenses with the requirement for complex document connections and anticipating edges between parts. You can control permeability, relegate the other appearance, and ascertain the mass for every strong body. When you finish the outline, you can send out the strong individual bodies as part documents straightforwardly into a get-together. Making a multi-body part is an effective top-down outline work process. You utilize regular displaying charges to make another body about different bodies. Utilize portray based demonstrating orders like Extrude, Revolve, Loft, Sweep, and Coil to make another body by choosing the New Solid choice in the exchange box. Utilize the Split summon with the Split Solid alternative to make isolated bodies in a section record. Also, one can use surfaces to define complex split boundaries, and the derived command to import components into a part file as new bodies or to use as tool bodies for a cut, join, or intersect operation.

### 5.2.5 Project

This project will start from the instructor, and he or she will be the one to choose what the project is going to be. Project 1 will contain 10 solid works part plus the final assembly. The 10 parts should be all fully defined and no part shall have any undefined parts. Creating more than 10 parts will not raise you a grade or even get you extra credit. It all depends on the overall look and design of the project. The instructor shall not make up anything from his mind, but he has to choose something related to the chapters and work studied in class. For example, the team has created a great example of the work that has to be done with 10 parts fully defined and an assembly that summed up the work. Lastly, there should be a brief explanation about each part was done. The pictures below will show a great example of how this project will work. The team has designed a Fan with 10 pieces and all the parts necessary to build a fan.



Figure 6: Fan

To create a fan, we shall have the most important factor, which is the fan itself. It was designed for a typical fan that is used in many places.



Figure 7: Fan Guard

The fan guard was created to assure safety and that people will not get any cuts from the fan.





**Figure 8: Fan Drum**

The fan drum was created to hold both the fan and the fan guard.



**Figure 9: Diverge**

The diverge is were



**Figure 10: Washer**

The washer is needed to tighten the fan together so that the screws hold tightly.



**Figure 11: Nut**

The Nuts are an important factor in building a fan.



**Figure 12: Sides**

The sides of the fan help in giving it its aesthetics.



**Figure 13:** Screws

The screws will hold most of the fan together.

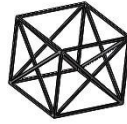

**Figure 14:** Wind Tunnel

The wind tunnel will help in the rotation of the fan.



**Figure 15:** Wheels

Project 2 will be anything that is naturally inspired/real life thing that the student will pick out. It will be a 10-piece part plus the assembly. It will be just like project one worth ten percent of the grade. The only difference in this project is that it should be completed and taken to the machine shop to work on it later. The Final overall shape could be done with fewer parts if it would be beneficial for the students, but the final shape should at least be the same one that was drawn in Solid Works. The student will be graded on the effort of the work done and not by the completion of the project.

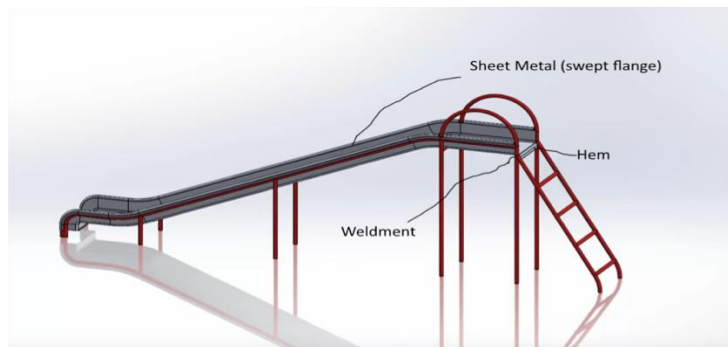

**Figure 16:** Slide Project

The theme is a guideline for the student that they will follow in their course. The idea of the theme is to make the student like what they are doing by making their interest in SolidWorks. They will use all the tools and features that they learned to do their theme by their interest. We as a team we will make sure that interest and we choose specific themes that related to their major. For instance, Lego theme, which will choose the creator Lego, by this type of Lego we can, made three shapes like car, plane, and truck. They will make the part of the Lego after that they can decide which way they want to do of the three shapes.

## **6 PROPOSED DESIGN**

This chapter will entail on what impact the lecture will have to the learners. The student will learn more about the ME380 and how it will prepare them to be expertise and professional in their field of study. It will further explain the kind of assignment and how they work as a team to ensure that every learner understands the topic in detail. Also, the kind of project they will handle as part of the homework. It will also explain the different design and how to create them, for example using loft technique to create an advance modeling.

### **6.1 Lectures**

The lecture is one of the toughest areas in any course. It means giving all the information that is needed by the learners to fully understand the course, what it entails and what impact it will add to the students. Concerning out the course which is ME380 we will ensure students become expert and professional specifically in substantial works, and therefore an outline on the flow of ideas and how the course looks like will be provided. For the learners to perform well in class, the instructor will give out enough information and ensure they understand the course in detail. New ideas will be explained, and students will be help on how to apply those ideas in class. The instructor will encourage group works so that student can collaborate to help each other in understanding the course. Even though some lesson student will be required to carry with them some drafting kit for drawing in class, and they will be assisted on how to use them.

### **6.2 Homework**

As a team, we will ensure the homework is efficient and can be easily tackled by the students. Before grading, learners will be helped on how to pass and on how to understand each topic in class. The homework will consist of two parts; the modeling in 3D and Solid works. Each will be done by hand, and another one which is homework will be done with program respectively. The second work will involve reviewing the solid work ME180 in class. That will entail topic that has been learned in engineering graphics. Previous work will also be examined for an easy understanding of the techniques and skills that will be taught in substantial works (ME380). In more details, I will majorly focus on animation features as a way of starting the course. The homework will come from the course work that will majorly focus on the introduction part of the course. The student will be allowed to finish the assignment within half an hour or an hour. They will use information from lecture and videos that have been posted on Blackboard. These will provide a framework to them on how the assignment should look like

### **6.3 Project**

Students will be assigned two projects concerning ME 380. The project will consist of the highest grade for the students, which will give them a better understanding of the project. The projects will be based on the choice of the student and the instructor. The instructor's choice will focus on the theme that will be

given to the student, and they will be expected to follow and use it in their work. Additionally, the student will create features with some parts such as weldment, sheet metal, loft and soft and motion. Each part should remain relevant to the theme provided to make it appear perfectly. The project will take five to six weeks to be completed, and learners will be required to have used the resources given. For instance, the videos that were posted on Blackboard and the group's works all should be incorporated in the assignment. It will ensure the student is well conversant with the course of substantial work.

## **6.4 Exam**

The second exam will have more features and tools for working. It will deal with loft technique using tools like base/boss loft, sketch point, derived design and curve through the reference points. The next part will be advanced modeling using tools like split line, surface thickens and draft analysis. Moreover, the last part is superior surfaces using tools like offset surface, ruled surface, and knit surface. In the loft technique, the process will involve creating sketches using loft process and 3D curve to connect the sections of the drawings. Then you use the pictures to drive or copy the curve. While in the reference point, you use the curve to guide and control the transition between the loft profiles and the points. However, in advance modeling, you take surfaces and combine to form complex free form shapes that will manipulate the imported files from the card formats. Then you knit together, from there, use the thickening tool to make the depth of the surface. Finally, calculate the angle between the faces of the surface using draft analysis tool. In addition to the advance surfaces, create the new surface from the set of faces with a distance of zero or greater using offset surface tool. Secondly, you form a new surface from a set of edges using rules surface tool, lastly using both offset surface and ruled surface together with knitting create a reference surface.

## **7 Implementation**

To successfully undertake the SolidWorks course, a learner needs a clear understanding of the curriculum offered. Also, the assessor and the school board only award academic credit to students who show an excellent mastery in designing available 3D models and assemblies. The program also incorporates TA's whose task is to impart knowledge to students to handle problems within the course and in the industry.

Our group builds by five students that undertook a study to establish what changes can help to improve the curriculum by preparing the learners to work on the project. The researchers aimed at deliberating on the concepts stipulated in the course outline during the study. The researchers began by formulating the objectives and the principles that would guide the study. The principal considerations included the effectiveness of the teaching methods and educational outcomes.

Since the course requires a lot of concentration, the chosen methods had to be attractive and friendly to the learners. One of the approaches discussed was the use of videos. The use of videos in a learning process is extremely beneficial since it enables students to view the concepts visually enhancing their understanding. The study revealed that a majority of learners prefer learning using videos since all students are fond of watching videos. As such, this learning model is friendly and familiar to all learners. Nonetheless, other students prefer learning methods that entail exposure to the involved technologies.

Another analytical model is the use of the tutorials specifically designed to fit the course. One designs a learning tutorial such that it accommodates a complex curriculum and divides it into segments. The purpose is to make students understand one concept at a time. The model also enables the learners to understand the structures in 3D. The selected models presented in this article aim at enhancing natural understanding and delivering knowledge in a method easy for students to understand [22].

The curriculum design also follows the proposed design in section six, which enables the team to stick to it and meet the outlined plan. Since the project used sources such as YouTube and real examples, the project members did not encounter any major problems in executing the undertaking. As a team, we also used some advanced techniques contained in books other than the tutorials that in SolidWorks programs.

## **7.1 Analytical Analysis**

In this section, we will introduce two new analytical analysis for the second semester. Which will be about videos about lectures and tutorials exercises from SolidWorks itself.

### **7.1.1 Videos**

Videos constitute one of the appropriate and most efficient methods of affecting knowledge. The course entitled “dealing with the SolidWorks” entails intensive concepts, and hence the use of videos during learning is paramount. The designers of the unit divided it into several sections to enable learners to grasp them bit by bit. One of the main advantages of the method is that it is useful for all types of students. Videos used for learning include diagrams to make the process of internalizing concepts easier. Parts and shapes are other major inclusions in the videos used for learning. These representations facilitate the process of comparing two or more quantities. One advantage of using videos is that they allow for the repetition of ideas to boost the viewers’ understanding of the concepts.

The idea is to ensure that all learners well considered and taken care to make the learning process enjoyable. The unit consists of several sections with each section covering all the concepts lying under it. One can also use the videos when lecturing or present assignments. A good example is the first assignment, which involves 3D modeling. The task requires drawing all the sketches. A student can draw the designs using drafting kit and present them to the class. Such an undertaking is beneficial to a learner since it gives them a chance to create the sketches and present them.

Another advantage is that the students have access to the video anytime giving them the freedom to conduct personal studies at their comfortable pace. The reason is that some learners are quick while others are slow in learning. Since every student has a distinct learning speed, it is our duty to come up videos that will enhance each learner’s understanding.

The additional advantage of using videos is they are readily accessible at any time. Students can use mobile phones, personal laptops, or other electronic devices to watch the videos, making the learning process extremely interesting. Every student enjoys studying when they are in the mood, and therefore the use of videos makes access the notes when they want. The only major duty of our team is to create a link to the uploaded video. The learners would then proceed to watch the video and use it for learning.

The other advantage of using videos is that they can quickly facilitate distance learning. The method also reinforces other learning approaches since it is an innovative measure that engages the student in the learning activity. They provide in-depth knowledge by setting up examples consistent with concepts learned using other approaches. One such concept is the defining of the parameter associated with the SolidWorks and offering solutions to some of the common problems. Since the team avails the videos in advance, they facilitate learning since a learner can relate what they watched earlier with what the lecturer is teaching in class.

Another benefit of suing videos for learning is that they enable the learners to catch up, especially if they miss the class session for any personal reasons. As such, a video helps the students not to lag behind the rest in observing the curriculum. For instance, if the lecture was about the outline of the assembling. In such a case, the students only need to access the video that explains and shows the operation. Another pro is that videos offer a chance for self-study since the learner interacts with relevant materials. For instance,

if they want to learn about the toolbar, one can just look for a video containing the relevant information and proceed with learning. Also, the student can use it as a way of improving his or her skills in handling of the tools in assembling process.

### **7.1.2 Tutorials**

A tutorial is a presentation specifically designed to fit the course. The intent is to integrate every piece of knowledge presented through images and other methods. One of the principal advantages of a tutorial is that they give students a better understanding since they offer the appropriate visual aids. The concept in the tutorials is one covering the SolidWorks with the practical projects. A SolidWorks tutorial may also contain 3D images designed like tools and other concepts. It is appropriate since the learner can understand the insight of what they need to do and what they have covered so far. If one does not know how to draw, they should follow the tutorial to come up with similar pictures. The advantage is that the students can validate their skills by the follow-up to the content of the tutorials and integrate with what they have learned in class.

After the learners have covered the course content, they are now entitled to come up with their projects. At this stage, tutorials are essential since they give guidelines that enable the learners to execute their projects successfully. They also allow the student to handle some of the complex tools. Hence, the use of the tutorials is beneficial in the practical and the application concepts related the course. Most of the concepts involve handling of the 3D tools and equipment making most of the parameters easy to understand. Therefore, tutorials are one of the best learning approaches since they make it easy for learners to understand academic concepts.

## **7.2 Design Changes**

The team used the stipulations and guidelines from Section Six to update the changes. The team keenly developed the initial plan in the exercise, and there were no problems encountered in the formulation of the scheme. We kept updating the section as the research progressed as per the intended design. The sources used include YouTube, advanced techniques of the substantial works, real life examples, and tutorials encompassed by the course program.

### **7.2.1 Hardware review 1**

The team shared the task to each team members after explaining the research alongside all the concepts covered to the advisor/client. The team convinced the advisor that they had done the right project and met all the criteria. The team consisted of five members each assigned an individual task to complete. Yousef had the duty to execute homework 9 and 10 alongside project 2. Muhammad Alhajri completed homework 1 and 7 alongside exam 3. Naser worked on homework 5 and 6 other than formulating of exam 2. Muhammad Alfadhli worked on homework 8 and 11 with project 1. Abdulaziz assigned with three homework that is 2, 3, and 4. After the completion of the individual task, the team compiled the material to come up with a comprehensive final document to present.

The work was organized efficiently and systematically to ease the work of the presentation. The team then gave a copy of the document to the advisor/client arranged it accordingly. The team then conducted a professional presentation by the techniques of SolidWorks. In the course of executing the project, the team gained knowledge and unique methods of dealing with problems related to the course.

### **7.2.2 Hardware review 2**

The team did a great job to finish the remaining part of the project. The section comprised of lectures from one to twelve and the inclusion of videos alongside an exam 1. The target was to complete the task before the end of the semester completed. The team divided the task equally among the five members.

After completing the task, each team member compiled their findings and presented them to the advisor/client.

The team recommended that need to incorporate videos when preparing their lectures. Attaching a video would make it easy for learners to understand the concepts easily. The team also observed that a good video would take a duration of about 5-10 minutes. Videos help the students to understand the concepts of the course and most of all features in the unit. Abdulaziz was to present to advisor exam one which was the only remaining part. On the part of hardware review, the team was to follow the guidelines and the comments of the clients. The team followed the instructions and completed the project.

## **8 TESTING**

The primary aim of testing was to establish the performance of the project against the initial requirements stipulated in Chapter Two. Specifically, these requirements include customer requirements (CRs), engineering requirements (ERs), and the house of quality. Testing is considered a critical stage of project management due to its ability to provide a preview of the expected performance. As such, a comparison of actual performance and the desired performance can be made, and the necessary changes to the design are adopted. Additionally, testing can lead to the proposed project being dropped, where, a significant number of the initial requirements are not met; therefore, modification considered impossible.

Customer requirements were critical to the project since the new course had to satisfy a significant number of them to replace the existing course. One of the course requirements was to provide the students with an ability to establish, formulate, and develop solutions for the engineering problems. The selected design was tested for summative and formative approaches of evaluating skills and knowledge acquired. The existence of pre lecture quizzes, iterative tests, and post-instruction evaluation were all considered. Every category of tests was awarded five points to contribute to the overall course performance.

Apparently, the proposed course consisted of nine pre instruction quizzes, in semester exams and a post instruction exam, which enabled the proper assessment of students' acquired knowledge. Therefore, the students' score in the tests revealed the ability of the course to enhance the students with the capability to establish, formulate, and derive solutions for engineering problems. The course satisfactorily satisfied this requirement; hence, scored fifteen out of the possible points.

From the new requirements proposed by the team, there existed no lab sessions in the class. Therefore, the course did not provide the students with an avenue to design, conduct experiments, analyze, and design data. Hence, the score for the course in this requirement was zero. This requirement was tested by checking for availability of avenues, which enhanced the student to demonstrate the ability to use techniques, skills, and modern engineering tools. The existence of such avenues contributed to five points in the final score for the course.

The course involved nine assignments about advanced solid works, supposed to test the students' ability to utilize skills, techniques, and modern tools. Therefore, the students' performance in these assignments provided a measure of the course to satisfy this attribute; hence, scored five points.

The existence of lectures aimed at imparting knowledge on how to use computers aided designs packages was used as proof that the course designed to assist students in acquiring such knowledge. It contributed five points. Advanced 3D tutorials were found to play the role of enabling students to utilize solid model capabilities of CAD such as Auto CAD to develop three-dimensional solid models. The course satisfactorily satisfied this requirement; hence, scored the total five points by involving lectures that equipped the students with the knowledge to use Auto CAD in the development of 3D solid models.

Testing of this feature was conducted through examination of the availability of avenues that could establish the knowledge of students on the topic. The existence of such avenues also contributed five points to the score of the entire course. Testing of the process for this attribute revealed that there existed assignments on solid works, which evaluated the students' ability to create drawings was tested in this attribute. The performance of students in these assignments was an adequate measure of this aspect. Availability of lectures to assist students in using solid modeling earned five points for the project.

A formative testing technique was used to evaluate the ability of the course to enable students to sketch free hand pictorials. The ability of the course to enable the students to draw free hand pictorials contributed five points towards the final score of the project. The students were supposed to complete three assignments on 3D drawing, which provided a measure of their ability to sketch free hand pictorials. The students' performance in this category offered the best avenue to evaluate the ability of the course to support this aspect.

Testing of this aspect was conducted by checking the presence of a project that would help the students with the knowledge to assemble different parts to create one item regarded as the project. The existence of lab sessions in the course was tested to ensure that the course gave the students the ability to read engineering scales. The presence of lab sessions contributed five points towards the final score of the course. The existence of a project also contributed the same amount of points towards the course score. This aspect was satisfied halfway by the final project. The lack of lab sessions of the course meant that the course could not equip the students with the necessary skills to read engineering scales. Therefore, the course scored five points in this category.

The overall performance of the project to satisfy customer requirement was forty-five points out of the possible fifty points. Therefore, the course was able to satisfy most of the customer requirements. Compared to the previous ones, the project was by far better in equipping the students with skills and knowledge desired by the market. One of the areas that it has been found lacking is the inability to provide lab session that could equip the students with skills in the areas of reading engineering scales and perform the experiment. Hence, for the course to meet all of the customer requirements, lab sessions are supposed to be included in the syllabus.

## **9 CONCLUSIONS**

In this section, we will introduce two part of the post mortem analysis conclusion of the project. Which will be contributors to project success and opportunities for improvement.

### **9.1 Contributors to Project Success**

From the beginning, the team was formed with a major aim of making the solid works' coursework more creative and flexible after the course lessons were identified as no longer fit to the class. Therefore, the primary goal of the team was to come up with a course that could enhance the students to complete it with top honors, by the use of their creative talents. Additionally, SolidWorks required students with a strong desire to the creativity boundaries because of the nature of sketching and drawing animations and multi-body features. Therefore, the team was interested in making the course more creative to ensure students own their work; hence encouraging other students interested in solid work course.

The project proposed by team reveals that the team was able to meet their purpose and objectives as stated in the charter. Apparently, the project satisfied its purpose of making the course more creative and flexible. The course involved new teaching methods such as the use of online videos, which are more enjoyable to the students. On matters regarding ground rules, the team was able to meet most of them and followed the coping strategies where the plans were failing. For instance, the team was able to modify the



engineering requirements to ensure that a limitation of time was dealt with without affecting the quality of the course. Additionally, no cases of lateness or the lack of attendance were reported.

Distribution of the tasks, where everybody was allocated duties according to personal strengths, was the primary working strategy for the team. In this manner, every team member was able to execute his duties with a high rate of success. Therefore, the quality of the final product was the major positive aspect of the project. However, due to the team members' availability issues, time management was one of the negative dimensions of the project. The lack of proper time management led to the scaling down of the engineering requirements; hence, affecting the quality of the project. In carrying out the project, the team used personal strengths to ensure that they successfully achieved the task. Additionally, the team used phones to shoot the lecture and assignment videos for the new course. The use of personal strengths and proper management of time were the major aspects that led to successful completion of the project.

The major problems encountered by the team in carrying out the task were acquiring the videos for the lectures. Some challenges were met especially when the team could not obtain videos from the department. The team had to result in shooting the videos using phones, which had a memory limitation; hence, produced to use tutorials where videos could have played a better role. The organization must ensure that such critical resources required by such a team can be accessed directly in future to ensure a smooth running of projects. Despite few challenges experienced, the task had numerous technical lessons to offer. One of the many issues that the project offered was the importance of time management and applying teaching methods attractive to the learners.

## **9.2 Opportunities/areas for improvement**

Most of the engineering institutions possess a desire to provide students with skills and knowledge that matches the market requirements. As such, the schools aim at producing competent students able to succeed in their fields of specialization. In the engineering field, professionals are required to possess advanced knowledge of design tools and features to enable them to create more accurate and detailed engineering projects utilizing parametric and computer aided design tools. At NAU, the school of engineering had an original system code ME 180 known as engineering graphics, which targeted to equip the student with a basic understanding of the elementariness of computer aided design, graphical communication, parametric modeling, and drafting. With the course failing to meet the market requirement appropriately, the school of engineering requested for a change, executed by the project team. The team was able to meet most of the project requirement. However, there exist some few areas of improvement.

Although the team was able to complete it is the goals and purpose as stated in the charter, an involvement of lab sessions in the course syllabus was not possible; hence, the course failed to equip students with necessary knowledge of reading engineering scales and performing experiments. Also, besides following most of the ground rules, time management was still an issue due to the commitment of team members elsewhere. Therefore, the team needs to observe proper time management in the future to ensure a successful implementation of the project. Moreover, the videos enhanced the engagement of students with the course. However, the lack of adequate videos to the proposed course was a primary drawback to the course. Therefore, the team should consider the use of additional videos to make the course more interactive.

One of the issues encountered by the team as stated above was the proper time management due to the team members being committed elsewhere. Therefore, the organization should consider creating teams composed of people with no or minimal commitment elsewhere to ensure the maximum focus is given to the project development. The successful completion of the project offered various technical lessons including the need to include interactive teaching methods in any particular course. Moreover, since

interactivity varies according to a particular individual, a variety of methods should be considered to guarantee inclusivity to all students.

## 10 REFERENCES

- [1] D. M. Buede,, and W. D. Miller (2016). *The engineering design of systems: models and methods*. John Wiley and Sons.
- [2] Dassault Systems. (n.d). Discover Catia. [Online] Available. <https://www.3ds.com/products-services/catia/>
- [3] Knex. (n. d). Where Creativity Clicks. [Online] Available: <http://www.knex.com/>
- [4] G. E. Dieter and L. C. Schmidt (2013). *Engineering design* (Vol. 3). New York: McGraw-Hill.
- [5] Autodesk. (2017) *Autodesk*. [Online] <http://www.autodesk.com/>
- [6] Lego. (n. d). Lego Shop. [Online] Available: <https://www.lego.com/en-us/>
- [7] PC. (December, 2015). *MakerBot Replicator Mini Compact 3D Printer*. [Online] Available. <http://www.pcmag.com/article2/0,2817,2496251,00.asp>
- [8] PC. (August, 2016). *ROBO 3D R1 + Plus*. [Online] Available. <http://www.pcmag.com/review/347420/robo-3d-r1-plus>
- [9] Autodesk. (2017) *AutoCAD*. [Online] <http://www.autodesk.com/products/autocad/overview>
- [10] Proto 3000. (n. d). *Learn How to Get the Most out of 3D Printing for Product Development*. Available: <http://proto3000.com/fortus-400mc.php#Fortus-400-Tabs:Overview>
- [11] A., Rajic, E., Desnica, S., Stojadinovic, L., Lazic-Vulicevic, and S. Eric (2015). Reverse engineering and CAD inspection of knee implant using the Noomeo Optinum 3D Scanner. *Annals of the Faculty of Engineering Hunedoara*, 13(2), 39.
- [12] R. M., Simpson, T. L., McCluskey, W., Zhao, R. S., Aylett, and C. Doniat (2014, May). GIPO: an integrated graphical tool to support knowledge engineering in AI planning. In *Sixth European Conference on Planning*.
- [13] G. Q. Xu, and Z. C. Huang, (2007). Research on parametric design in its further development based on SolidWorks. *Ji Xie She Ji Yu Yan Jiu(Machine Design and Research)*, 23(1), 68-70

- [14] Meccano (2017) *About*. [Online] Available: <http://www.meccano.com/about>
- [15] Koller, D., & Friedman, N. (2012). Probabilistic graphical models principles and techniques. Cambridge, Mass.: MIT Press.
- [16] Jaynes, E. T., & Bretthorst, G. L. (2015). Probability theory the logic of science. Cambridge: Cambridge University Press.
- [17] Myung, I. J. (2003). Tutorial on maximum likelihood estimation. *Journal of Mathematical Psychology*, 47(1), 90-100. doi:10.1016/s0022-2496(02)00028-7
- [18] Pearl, Judea (1982). "Reverend Bayes on inference engines: A distributed hierarchical approach" (PDF). Proceedings of the Second National Conference on Artificial Intelligence. AAAI-82: Pittsburgh, PA. Menlo Park, California: AAAI Press. pp. 133–136. Retrieved 2009-03-28.
- [19] Dollar, Aaron M., Kerdok, Andrew and Paul Novotny. "Starting on the Right Track: Introducing Students to Mechanical Engineering with a Project-based Machine Design cCourse." ASME 2005 International Mechanical Engineering Congress and Exposition, 2005.
- [20] Chang, Kuang-Hua. *Motion Simulation and Mechanism Design with SOLIDWORKS Motion 2016*. Sdc Publications, 2016.
- [21] Tran, Paul. *SOLIDWORKS 2016 Basic Tools*. Sdc Publications, 2016.
- [22] Dieter, G. E., & Schmidt, L. C. (2013). Engineering design (Vol. 3). New York: McGraw-Hill.

# 11 APPENDICES

## 11.1 Appendix A: Work Breakdown Structure (WBS)

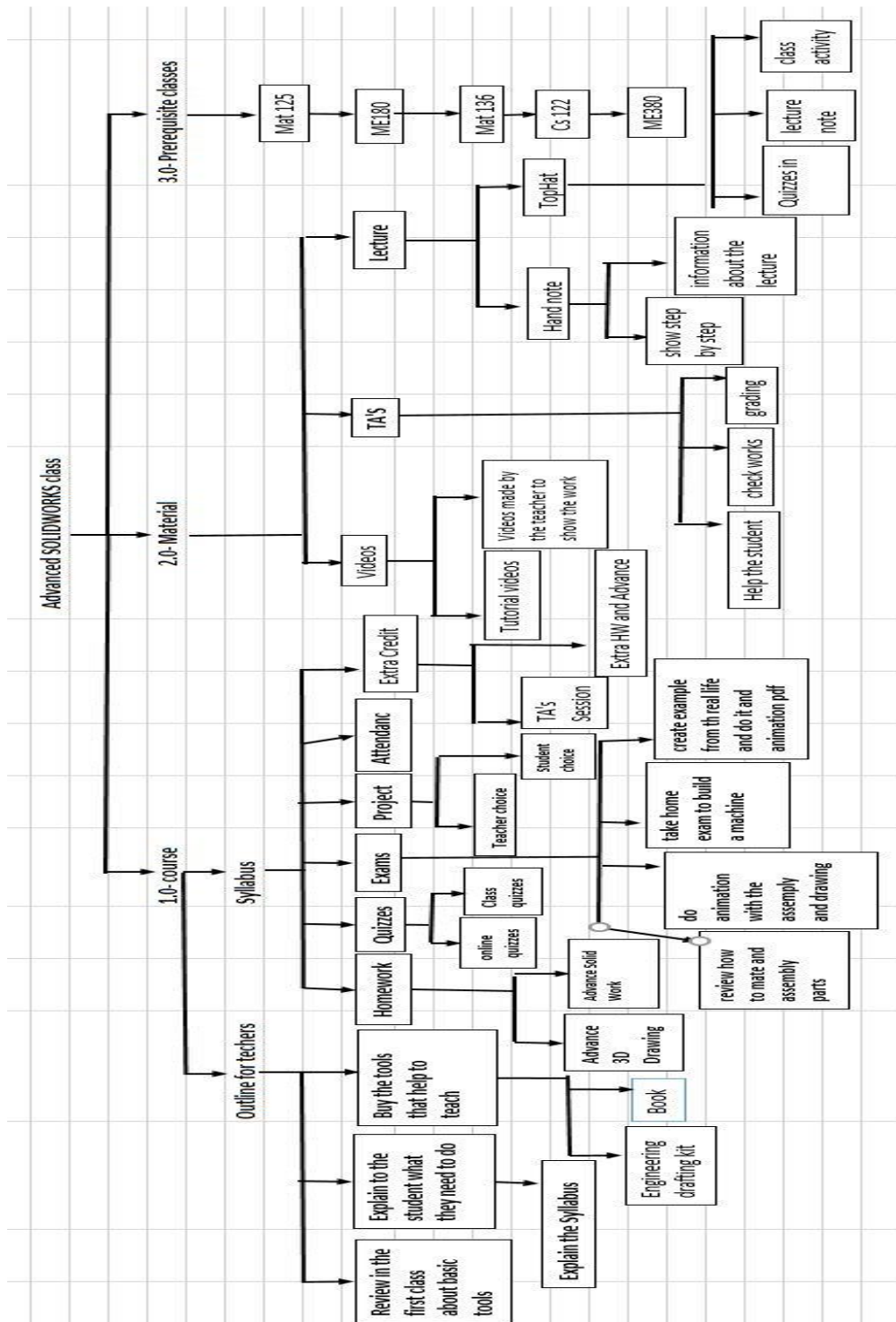

## 11.2 Appendix B: Exam

ME 380 (Advanced SolidWorks)  
Exam

Fall 2017

First:

Last:

/100

Include your first and last name in the parts file properties.

- 1) Model the following parts in SolidWorks with the given dimensions:
  - a. Base in figure 1 /10
  - b. Rotor in figure 2 /10
  - c. Blade in figure 3 /5
  - d. Lower Must in figure 4 /5
  - e. Upper Must in figure 5 /5
  - f. Shaft in figure 6 /10
  - g. Washer in figure 7 /5
  - h. Housing in figure 8 /10
- 2) Using SolidWorks, assemble the parts into Wind Turbine as shown in figure 9. /20
- 3) Use the animation tool to test the Wind Turbine work with 30-rpm speed. /15
- 4) Draw the assembly in the drawing sheet showing the dimension. /5

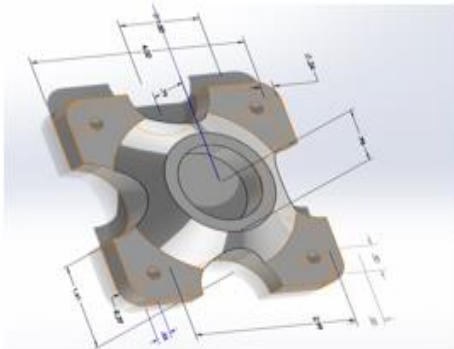

Figure 1: Base

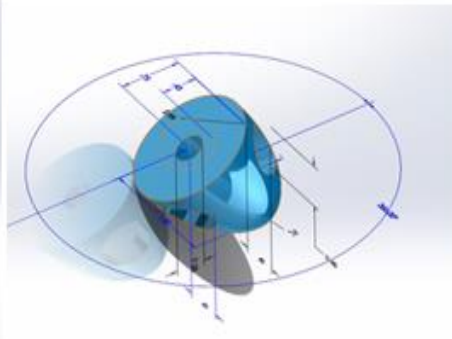

Figure 2: Rotor

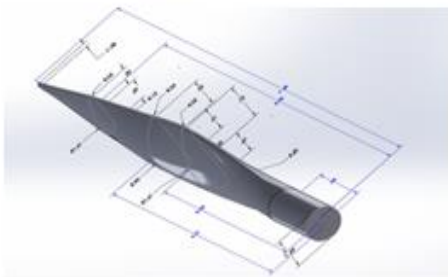

Figure 3: Blade

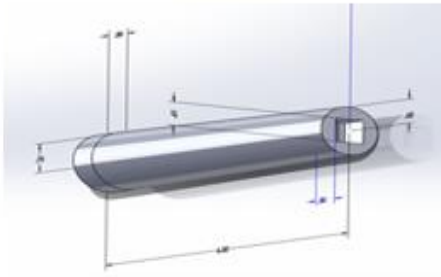

Figure 4: Lower Must

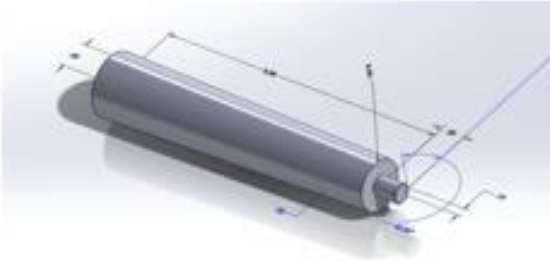

Figure 5: Upper Nut

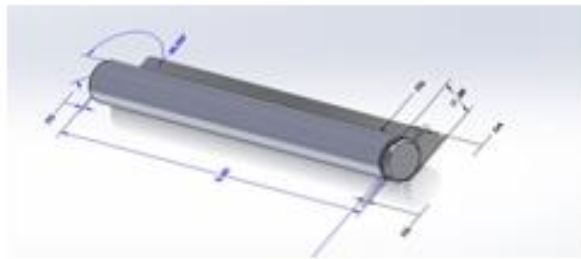

Figure 6: Shaft

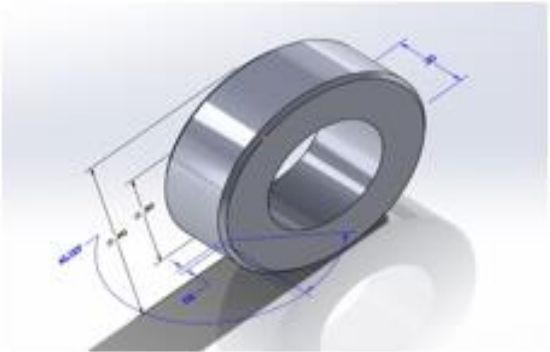

Figure 7: Washer

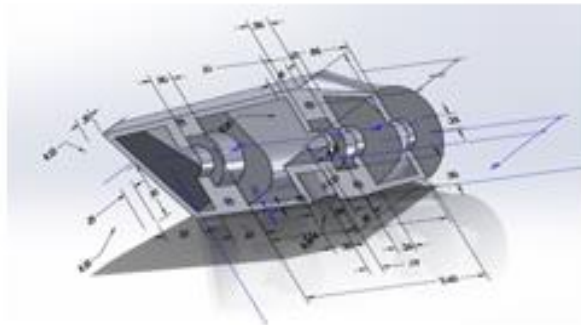

Figure 8: Housing



Figure 9: Wind turbine

11.3 Appendix C: homework 9

### Homework 9

(100 marks) Create the model with view is shown in figure 1. You will use Sheet Metal Features for this Homework. The other views and dimensions of the model are also given in the other figure. In order to complete this model, the tools needed are:

- 1- Line
- 2- Circle (0.25 in)
- 3- Base Flange (4.00in, 16 Gauge)
- 4- Edge Flange (90°, 5.00in)
- 5- Sketch Bend (90°)
- 6- Flat Pattern

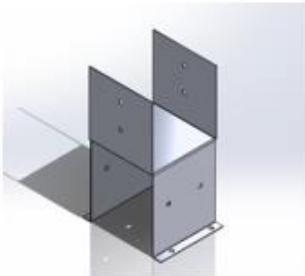

Figure 1

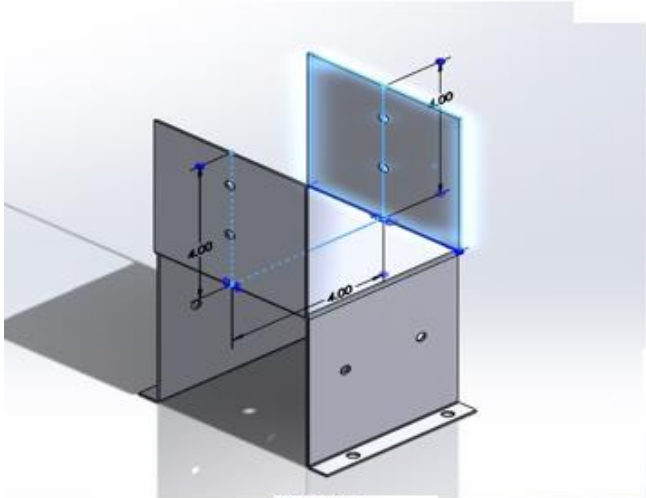

Figure 1-2

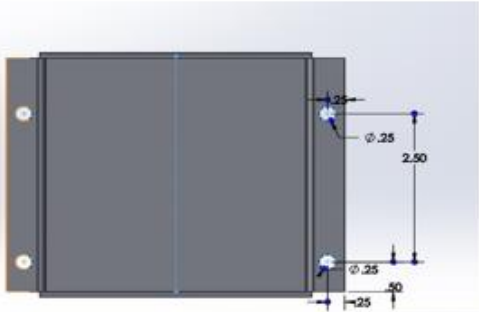

Figure 1-3

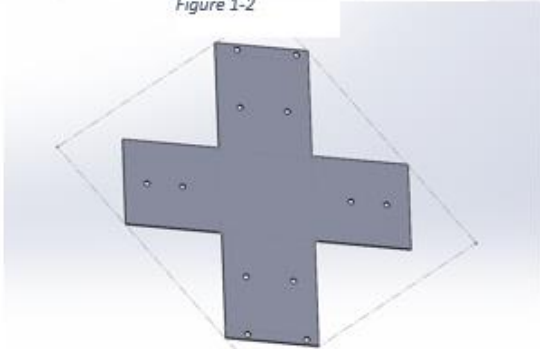

Figure 1-4

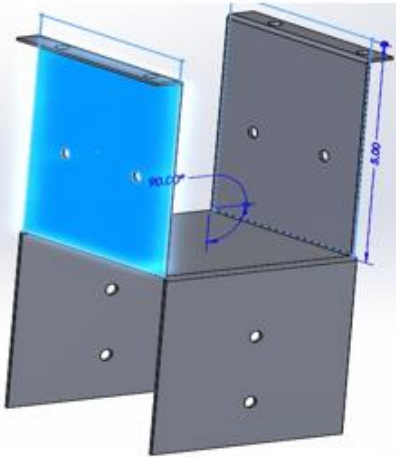

Figure 1-5



## 11.4 Appendix D: Lecture

# INTRODUCTION TO 3D SKETCH

- Solid works will provide a platform to create 3D sketch
- 3D sketches include use of lines and arcs in splines and series
- A 3D sketch may be used as:
  - Sweep path
  - Guide curve
  - Centerline for loft
  - Key entity

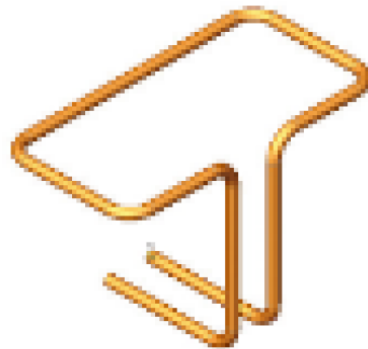

# PARAMETERS

- Y Coordinate
- X Coordinate
- Z Coordinate
- Curvature (The Spline Curvature)
- Tangency (In XY plane)
- Tangency (In XZ plane)
- Tangency (In YZ plane)

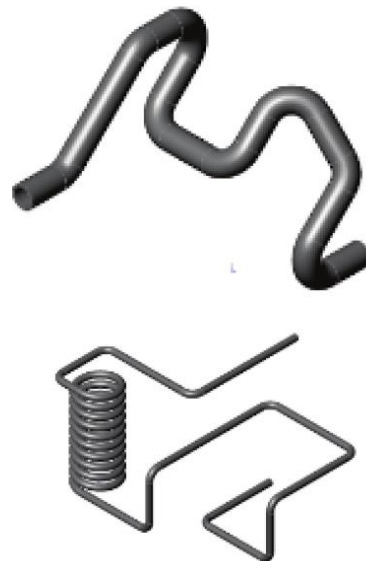

# TOOLS NEEDED



# STARTING A NEW PART

- Click File/New
- Then select the Part template then click OK

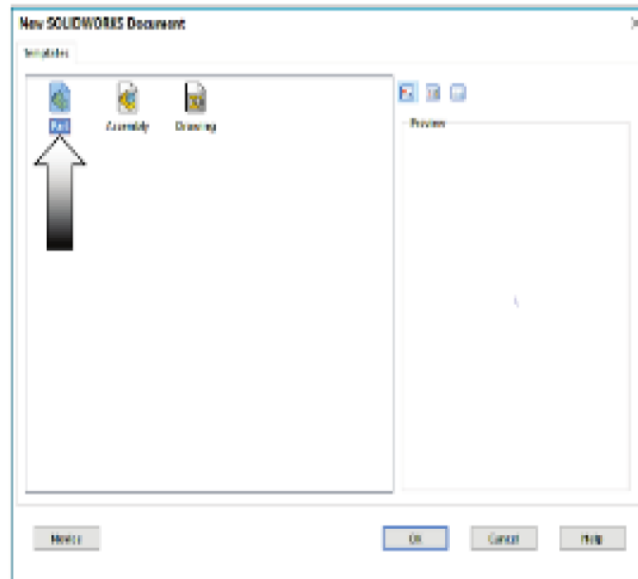

## CREATING A 3D SKETCH

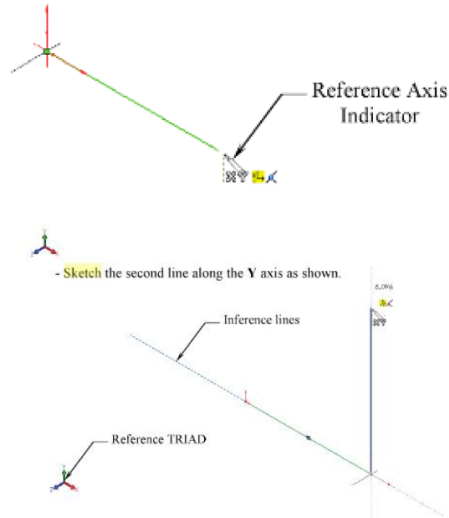

- Click 3D or go to insert/ 3D Sketch
- Change Isometric view
- Select Line tool
- Sketch first line along X axis
- Sketch second line along Y axis

## CHANGING DIRECTION

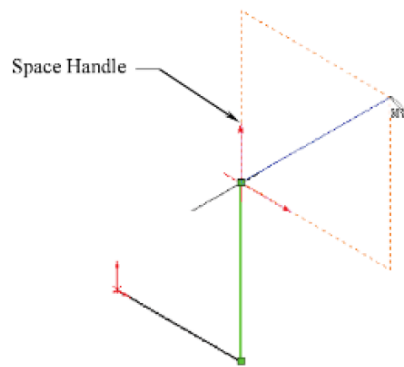

- The sketch is relative to default coordinate system within the model
- Press TAB key and reference origin of current sketch plane to switch to planes

## COMPLETING THE PROFILE

- Follow axis shows
- Press TAB button when necessary in order to change direction

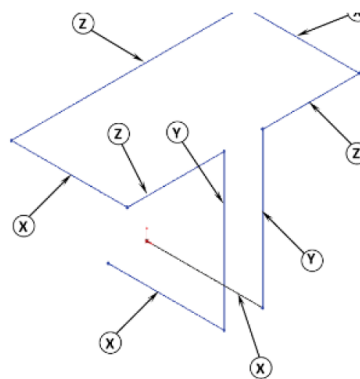

# Advance SolidWorks ME380

Lecture  
Sheet Metal

## Introduction

- Gain the flexibility to quickly and cost-effectively create sheet metal part designs using SolidWorks, accelerating the design process, saving time and development costs, and increasing productivity. Using SOLIDWORKS you can:
- Design SOLIDWORKS 3D solid sheet metal parts and assemblies
- Convert SOLIDWORKS 3D models or imported CAD models directly to SOLIDWORKS sheet metal models and automatically input your own bend radius, thickness, and K-factor

create the sheet metal part by following those steps :

- Creating a base flange
- Adding a miter flange
- Mirroring the part and creating new bends
- Adding an edge flange and editing its sketch profile
- Mirroring a feature
- Adding and bending a tab
- Adding a cut across a bend
- Folding and unfolding bends
- Creating a closed corner

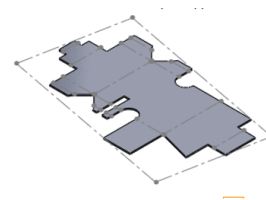
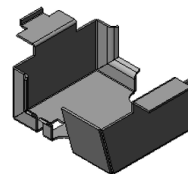

# Step 1

## • Creating a base flange:

- Open a new part.
- Click Base Flange/Tab
- Select the Front plane. A sketch opens on the Front plane
- Sketch and dimension the profile.
- Exit sketch
- In the Property Manager, under Direction 1: (Select Blind in End Condition) then (Set Depth to 75)
- Under Sheet Metal Parameters: (Set Thickness to 3 ) then (Set Bend Radius to 1 )
- Click check mark (Done)
- The sketch is extruded and the bends are added. ( It is going to be look like this pic)

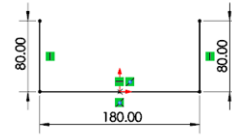

# Step 2

## • Adding a miter flange

- Click Extruded Cut (Features toolbar), and select the bottom face.
- Sketch and dimension a circle with its center coincident to the midpoint of the edge, as shown.
- Close the sketch.
- In the Property Manager, click Link to thickness under Direction 1, and then click check mark
- Click Wireframe (View toolbar).
- Click Miter Flange (Sheet Metal toolbar).
- Select the inside vertical edge as shown to create a sketch plane normal to the selected edge with closest endpoint of the edge. Make sure to select the upper portion of the edge.
- Click Bottom (Standard Views toolbar).
- Click Zoom to Area (View toolbar) and zoom to the sketch origin.
- Starting at the origin, sketch as shown:
  - 1- (Horizontal Line (Sketch toolbar), with an approximate length of 20.)
  - 2-Tangent Arc (Sketch toolbar), with an approximate radius of 10.
  - 3-Line (Sketch toolbar) tangent to the arc, with an approximate length of 6.
- Click Smart Dimension (Dimensions/Relations toolbar) and dimension as shown.

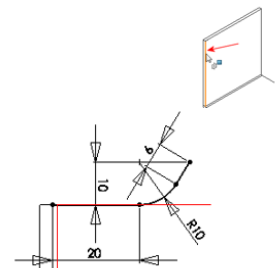
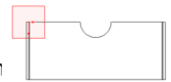
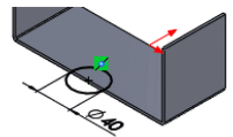

## Step 3

### • Completing the Miter Flange

- Click Isometric (Standard Views toolbar).
- Click Exit Sketch (Sketch toolbar).
- Click Propagate (The miter flange is propagated to the tangent edges, stopping at the notch. )
- In Miter Parameters, under Flange position, click Material Outside then click the check mark.
- Click Shaded With Edges (View toolbar).
- Save the part

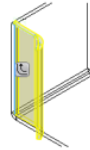

## Step 4

### • Mirroring the Sheet Metal Bends

- Click Back (Standard Views toolbar).
- Zoom to the right corner of the model's back face.
- Click Mirror (Features toolbar).
- Select one of the back planar faces, as shown, for Mirror Face/Plane
- Click Bodies to Mirror, and select the sheet metal body as shown, for Solid/Surface Bodies to Mirror. Then Done



## Step 5

### • Creating an Edge Flange

- Click Edge Flange (Sheet Metal toolbar).
- Select the outer edge as shown.
- Drag the edge flange as shown, and click.
- In the Property Manager:
  - Under Flange Length, set Length to 30 .
  - Under Flange Position select Material Outside .
  - Under Flange Position select Offset.
  - Under Flange Position set Offset Distance to 15 .
  - Under Flange Parameters, click Edit Flange Profile to display the Profile Sketch dialog box.
- Select the end points along the base flange (inside edge) and drag them towards the center as shown.
- Click Smart Dimension (Dimensions/Relations toolbar) and dimension the edge flange as shown.
- Click Finish to close the Profile Sketch dialog box and complete the edge flange.

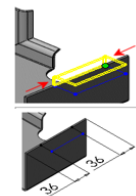
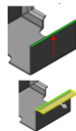

# Step 6

- **Mirroring a Sheet Metal Feature**

- Click Mirror
- Expand the Feature Manager design tree, and in the Property Manager:
  - Under Mirror Face/Plane, select Right Plane for Mirror Face/Plane
  - Under Features to Mirror, select Edge-Flange1 for Features to Mirror

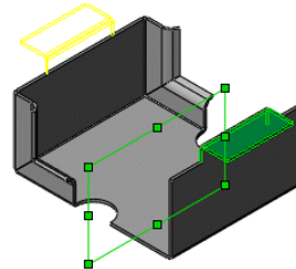

# Step 7

- **Adding a Tab**

- Select the face as shown, then click Base Flange/Tab (Sheet Metal toolbar). A sketch opens on the selected face.
- Sketch a rectangle, making one edge of the rectangle coincident to the upper edge of the edge flange.
- Dimension the rectangle to stick out 20 from the edge flange and be 40 long.
- Clear the Dimension tool.
- Add a coincident relation between the midpoint of one of the long lines of the rectangle and the edge flange:
  - Right-click one of the long lines of the rectangle, and click Select IV
  - Click Add Relation (Dimensions/Relations toolbar).
  - Right-click the long edge of the mirrored edge flange, and click Sel
  - In the Property Manager, under Add Relations, click Horizontal, th

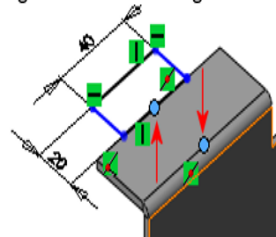
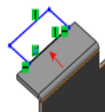

It's going to like this

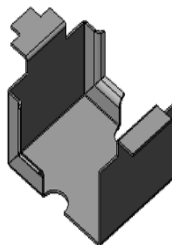

# Step 8

## • Bending a Tab

- Select the top face of the tab, then click Sketched Bend (Sheet Metal toolbar).
- Sketch a horizontal line of any length. Dimension it as shown. Then Exit Sketch
- In the Property Manager under Bend Parameters:
  - Select the face with the sketch below the bend line for Fixed Face
  - Click Material Outside
  - Set Bend Angle to 90.
  - Select Use default radius.

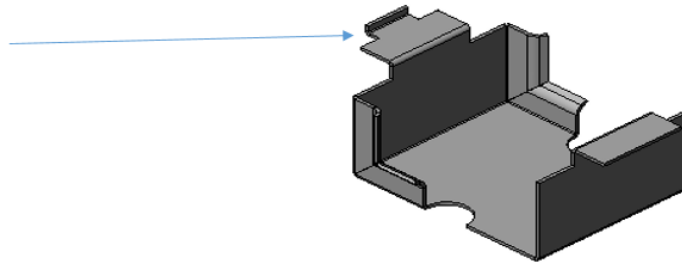
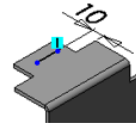

# Step 9

- Adding a Cut Across a Bend
- Click Unfold (Sheet Metal toolbar).
- In the graphics area, select the face and bend as shown for Fixed face and Bends to unfold.

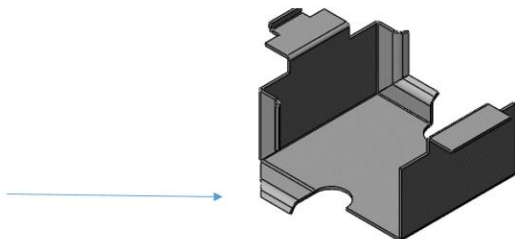
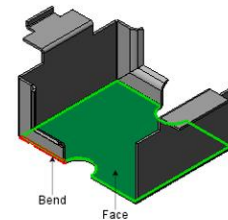



## Step 10

- **Creating a Cut Through the Bend**

- Click Extruded Cut (Features toolbar).
- Select the face shown, and click Normal To (Standard Views toolbar).
- Sketch and dimension a rectangle, and add a Collinear relation between the rectangle edge and the edge of the edge flange as shown.
- Click Exit Sketch
- In the Property Manager, under Direction 1, select Through All in End Condition.
- Click Isometric (Standard Views toolbar).

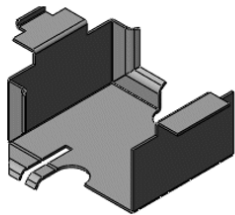
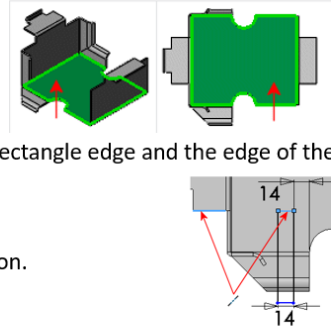

## Step 11

- **Completing the Cut Across the Bend**

- Click Fold (Sheet Metal toolbar).
- In the Property Manager, click Collect All Bends to add all unfolded bends to Bends to fold.
- Click check mark to return the part to its bent state.

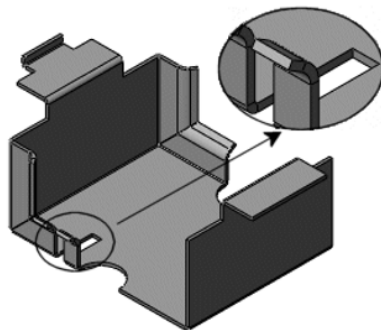

# Step 12

## • Creating Closed Corners

- Click Edge Flange (Sheet Metal toolbar).
- Select the edge as shown
- In the Property Manager:
  - Under Angle, set Flange Angle to 75.
  - Under Flange Length, set Length End Condition to Blind.
  - Under Flange Length, if the preview faces down, click Reverse Direction
  - Under Flange Length, set Length to 85
  - Under Flange Position select Material Outside
  - Under Custom Relief Type, in Relief Type, select Rectangle.
  - Under Custom Relief Type, select Use relief ratio.
  - Under Custom Relief Type set Ratio to 0.3

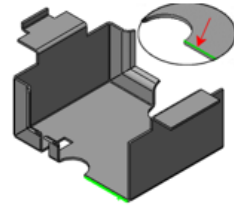

# Step 13

## • Completing the Closed Corners

- Click Closed Corner (Sheet Metal toolbar).
- Select the face of the base flange as shown for Faces to Extend.
- Select Butt for Corner type.

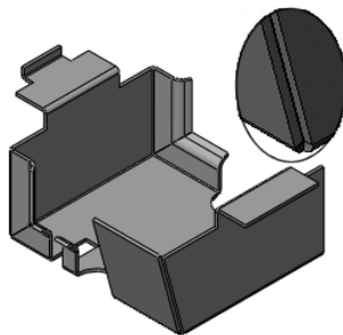
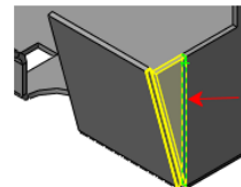

# Step 14

- **Flattening and Folding the Part**

- Verify that the rollback bar is rolled to the end, then click Flatten (Sheet Metal toolbar). And its going to be like this by using **flatten**.
- To fold the part back up, click Flatten aga

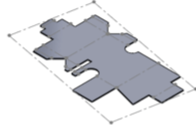

- This is the final look for the Sheet metal in SoildWorks

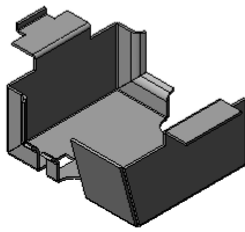

## 11.6 Appendix F: Homework Prototype

### Homework 5

(100 marks) Create the model with the views is shown in figure 1. You will use Loft features for this Homework. The other views and dimensions of the model are also given in the other figures. In order to complete this model, you will need to fully define the model and get the right dimension.

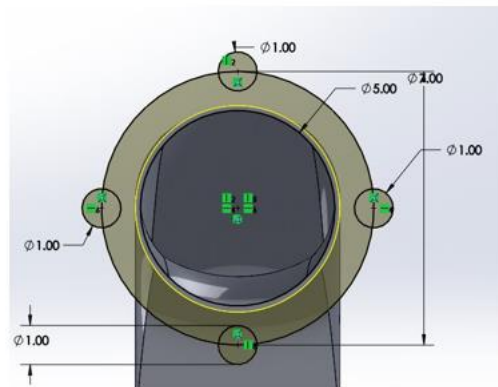
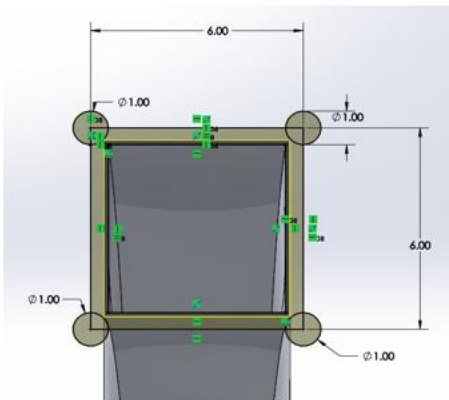
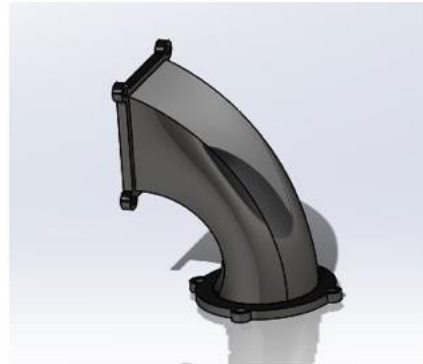
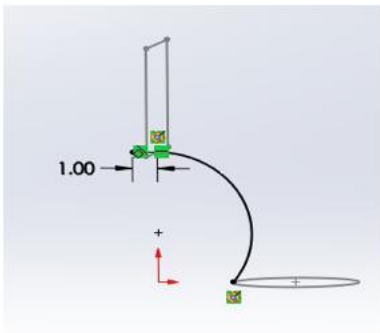
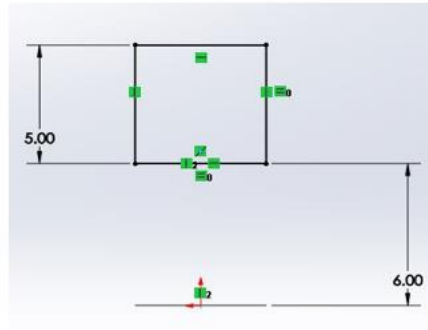
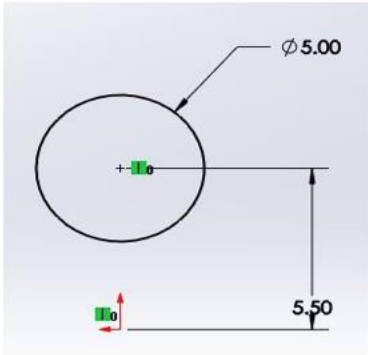

## 11.7 Appendix G: Project Prototype

### Project 2

For project two, you will assign to choose a model from real life example and apply it in SolidWorks. The project need to be creative and professional to get a full mark. In addition, it has to be more than 10 parts using the advance features that you have learned from the course.

An example for the features that the student need to use to complete this project:

- 1- Surface-Extrude 1
- 2- Sheet Metal
- 3- Convert solid

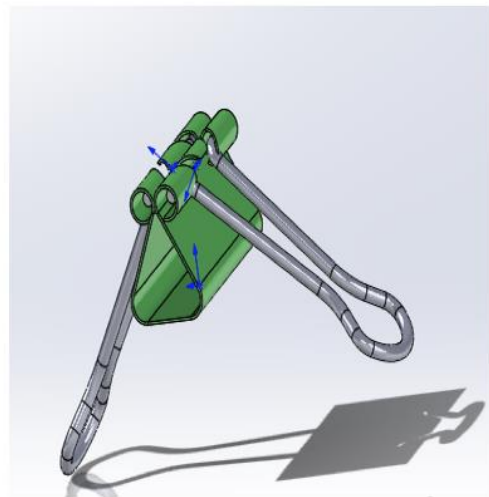
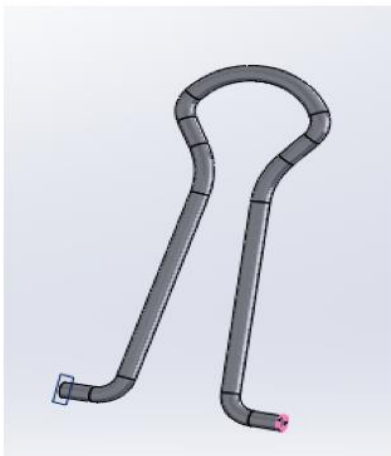
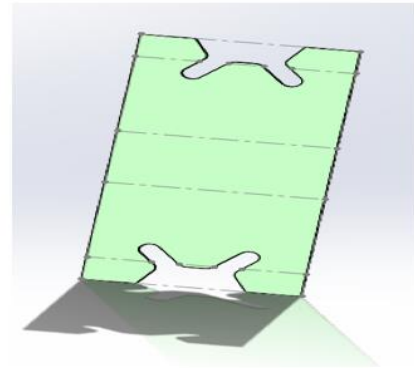
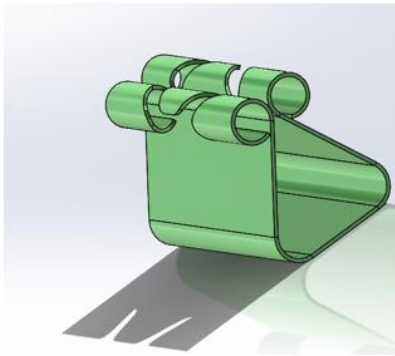

## 11.8 Appendix H: Exam Prototype

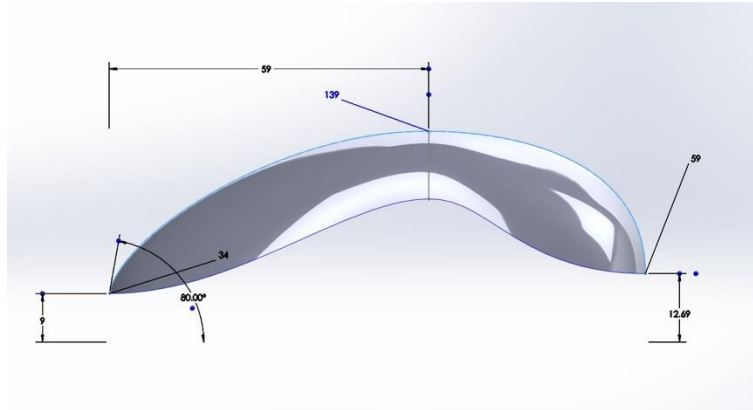

Figure 1:

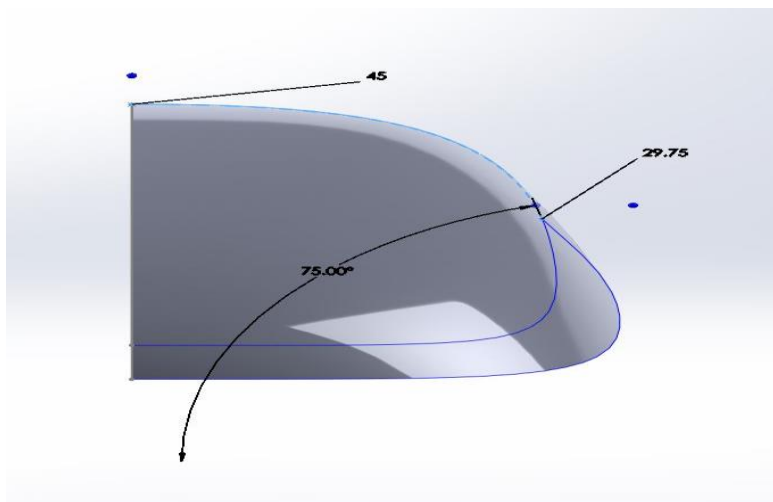

Figure 2:

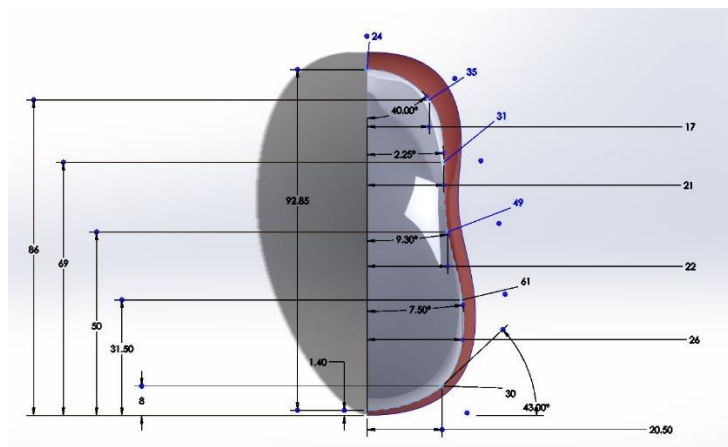

Figure 3:

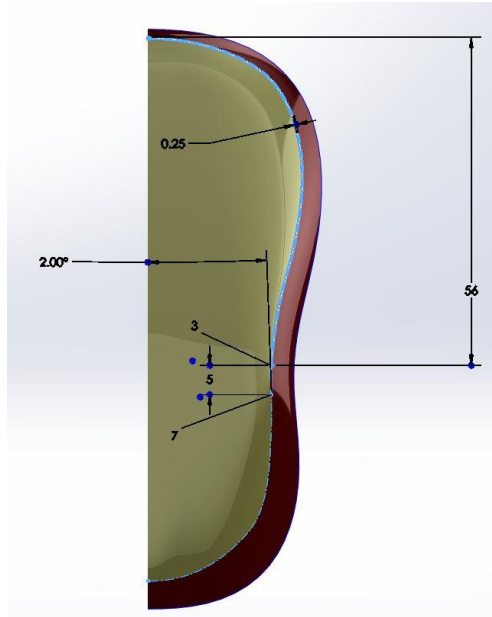

Figure 4:

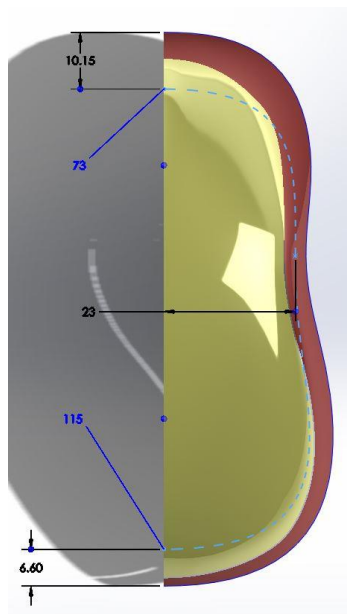

Figure 5:

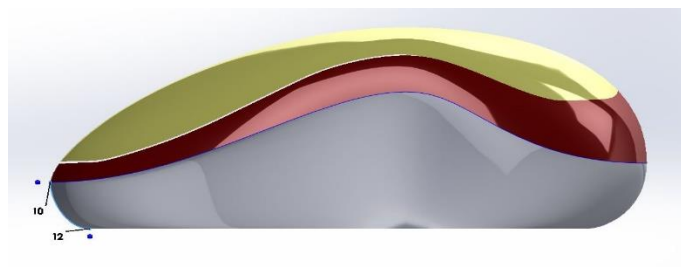

Figure 6:

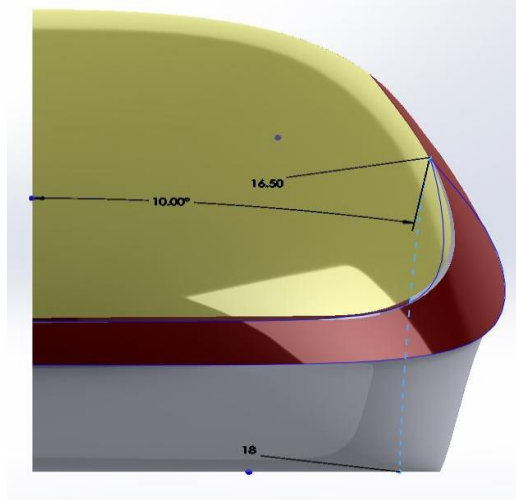

Figure 7:

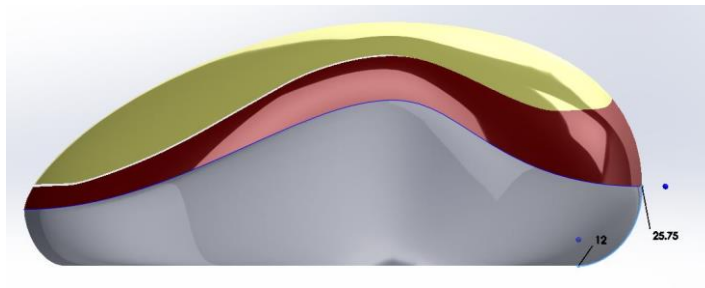

Figure 8:

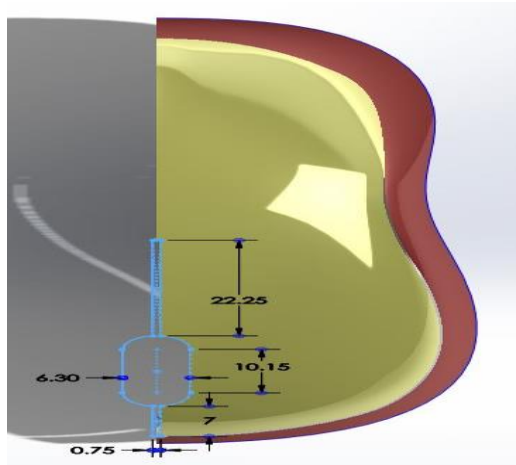
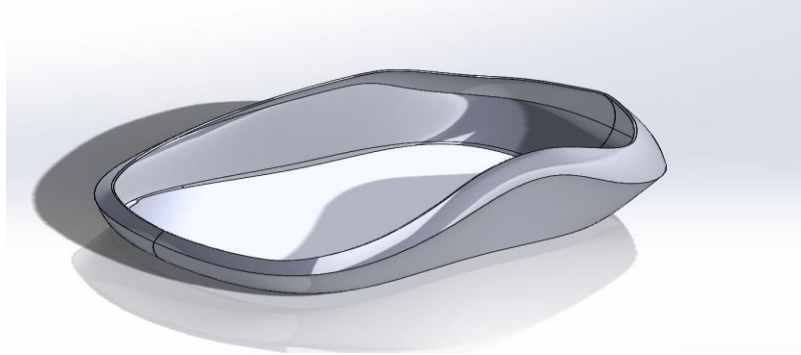
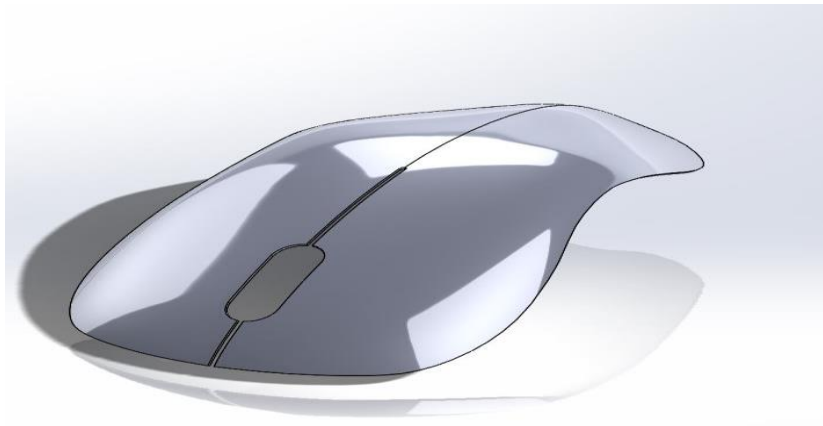

Figure 9:

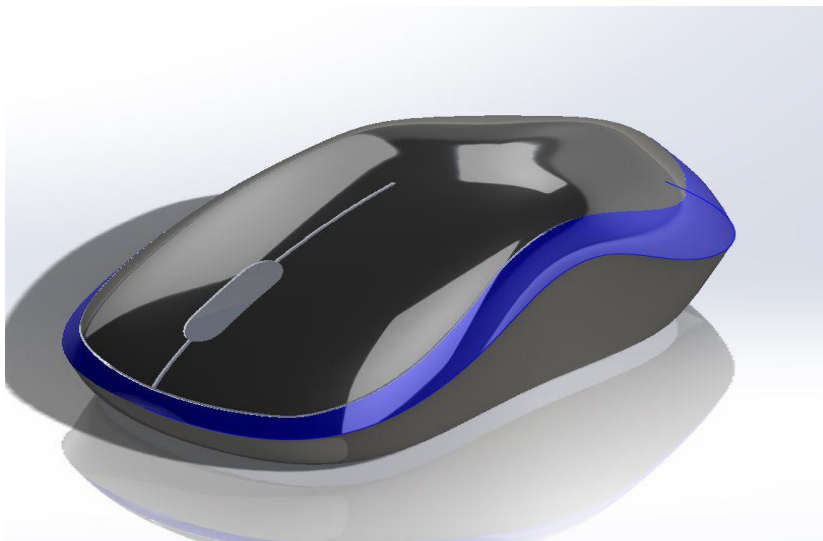



*Figure 10:*



*Figure 11:*



*Figure 12:*