

# 2015-16 SAE Baja

By

Fahad Alajmi, Sean Collins, Peng Li,  
Auston Solway, Maximilian Whipple and Jingyuan Zhang  
Section 3 Team 13

## Midpoint Review

Document

*Submitted towards partial fulfillment of the requirements for  
Mechanical Engineering Design I – Spring 2016*



Department of Mechanical Engineering  
Northern Arizona University  
Flagstaff, AZ 86011

## Contents

Table of Tables .....	i
Table of Figures .....	i
1. Introduction.....	1
1.1 Project Overview.....	1
1.2 Project Goals .....	1
2. Design Modification .....	1
2.1 Muffler .....	1
2.2 Rear Suspension .....	2
2.3 Fuel Catchment .....	3
2.4 Transmission .....	3
2.5 Shifter .....	5
2.6 Frame.....	5
3. Current Progress.....	7
3.1 Muffler .....	7
3.2 Rear Suspension .....	7
3.3 Fuel Catchment .....	8
3.4 Transmission .....	8
3.5 Shifter .....	9
4. Updated Project Plan.....	10
5. Conclusion .....	11
References.....	12

## Table of Tables

Table 1: Impact Safety Factors .....	6
Table 2: Milestones to Complete Project.....	10
Table 3: Progress Schedule .....	11

## Table of Figures

Figure 1: Old Muffler Side View	Figure 2: Old Muffler Front View .....	2
Figure 3: Single Trailing-Arm Suspension .....		2
Figure 4: Fuel Catchment Design .....		3
Figure 5: Old Shift Forks .....		4
Figure 6: New Shift Forks.....		4
Figure 7: Addition of Guide Shaft .....		5
Figure 8: Old FEA Analysis	Figure 9: New FEA Analysis .....	6
Figure 10: New Muffler Front View	Figure 11: New Muffler Tubing View .....	7
Figure 12: Current two-link Suspension .....		8
Figure 13: Fork Designs.....		9
Figure 14: Representation of Shift Mounting .....		9
Figure 15: Layout of the Shifter and Transmission .....		10

# **1. Introduction**

## **1.1 Project Overview**

Since September 2015, the 2015-2016 senior SAE Baja capstone team has been focused on completing the vehicle from last year's Baja capstone team. The main focus for this vehicle has been completing the transmission, redesigning the rear suspension, developing a mechanism for shifting, and ensuring all other components of the vehicle comply with the SAE rules for the collegiate competition; these components include: modifying the muffler to fit within the frame, modifying the fuel catchment around the gas tank to protect hot engine surfaces, and ensuring the frame meets SAE specifications for the most current set of requirements.

The following document covers the above mentioned topics by expanding on the progress of each component and the goals for completing each task. Additionally, this document will also cover an updated project plan, a proposed date for having the Baja drivable and details related to the overall cost of the vehicle based on SAE Baja standards.

## **1.2 Project Goals**

The main goal of the Baja team is to have a drivable vehicle by April 1, allowing for time to test and evaluate various components on the vehicle and to make adjustments before developing the operator's manual for the vehicle. Rigorous testing of the Baja vehicle is required, to determine if the vehicle's current design is adequate for competition. The April first deadline allows for this testing to be done with adequate time to make changes as needed to the Baja vehicle for maximum performance in the SAE competition.

# **2. Design Modification**

## **2.1 Muffler**

In order for the Baja be eligible for the SAE Baja competition, the muffler had to be redesigned since it was outside of the frame boundary, a violation of the SAE Baja rules. According to the rules, the muffler has to be the original muffler and there should be no extra holes and tubing of the exhaust pipe. In addition, the exhaust pipe has to have an inner diameter of 1.25 inches. Since the old exhaust pipe had a sharp turn (Figure 1-2) which was not efficient enough to exhaust gas, a smooth curve is used for the new one with shortened pipe length.



*Figure 1: Old Muffler Side View*



*Figure 2: Old Muffler Front View*

## 2.2 Rear Suspension

The rear suspension was a focal point of failure do to the unpredicted horizontal loads. The trailing arm of the Baja was initially designed to be connected to a corner junction located near the front of the transmission mounts. During fabrication stage the trailing arm mounting brackets were relocated to the crossmember below the driver's seat. By relocating this mounting bracket, the Baja became susceptible to a horizontal loading on the trailing arm bushing that proved to cause a critical failure.

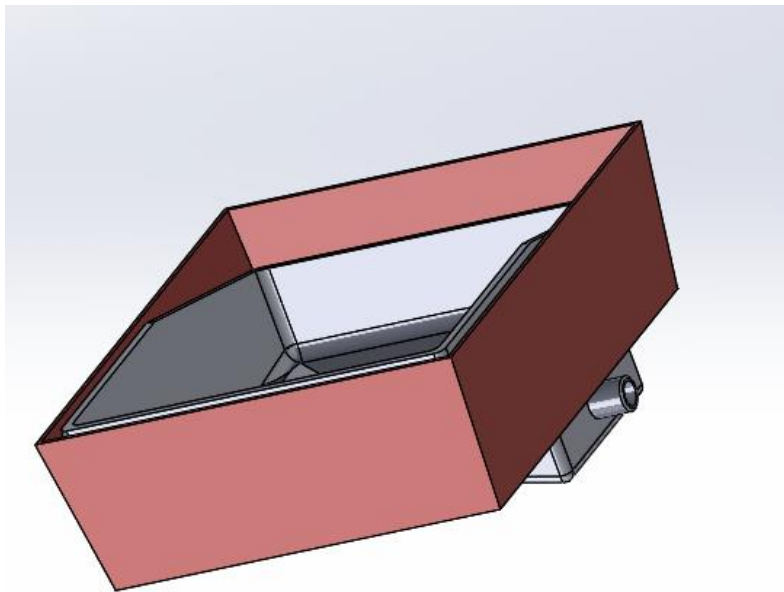

*Figure 3: Single Trailing-Arm Suspension*

Due to the new mounting location, which can be seen in Figure 3, the trailing arm of the Baja is mounting as a cantilever to the frame. This mounting style allows for the largest moment possible to be acting on the trailing arm bushing and mounting bracket. As the vehicle is accelerating through a turn the rear spindle, mounted at the end of the trailing arm, is the focal point for the Baja's momentum. This force not only creates a large moment on the mounting junction but also causes issues with the constant velocity shafts in regards to staying in the transmission. As the mounting junction bends, the spindle begins to have a change in distance in reference to the transmission. With this distance constantly changing, the CV shafts try to pull themselves out of their sleeves both in the spindle and the transmission. In attempt to resolve this issue, an alteration to the design was needed. The updated design utilized all of the same bracketry but included additional member(s) from the spindle to the frame.

### 2.3 Fuel Catchment

For fuel catchment at the first of this semester revise the project requirement to it, and made a new design that agreed with SAE rules for competition. A new design of fuel catchment is adding side shield to protect the fuel catchment of heat that comes from the muffler, shown in Figure 4.



*Figure 4: Fuel Catchment Design*

### 2.4 Transmission

Since the beginning of this project for the academic year, one major component has prevented the full operation of the transmission, the shifting forks. The forks from last year's design, shown in Figure 5 were composed of two separate pieces that were welded together, resulting in three shifting forks of inconsistent size.



*Figure 5: Old Shift Forks*

These improperly sized shift forks caused two major issues, the first issue was the improper fit within the transmission case and the second was a torsional load on the shift shaft, resulting in the binding of the forks on the shift shaft preventing the forks from moving linearly. Due to this design error, three new shift forks were each milled out of one solid piece of steel stock and tested, Figure 6.



*Figure 6: New Shift Forks*

The resulting shift forks were tested for proper fitness and for linear motion given the radial input of the shift shaft. Although the forks properly fit within the case, they still continued to bind on the shift shaft, the next solution to this problem was to add chamfers to the forks to prevent the tendency of the forks catching on the sharp edges of the shift shaft grooves. Although this helped the motion of the forks, it did not completely fix the issue. After further research into

sequential transmissions, it was decided that a guide shaft should be installed between all three forks to relieve the shear force applied on the shift shaft from the fork, this new design is shown in Figure 7. This iteration of the design process has proven to be successful.

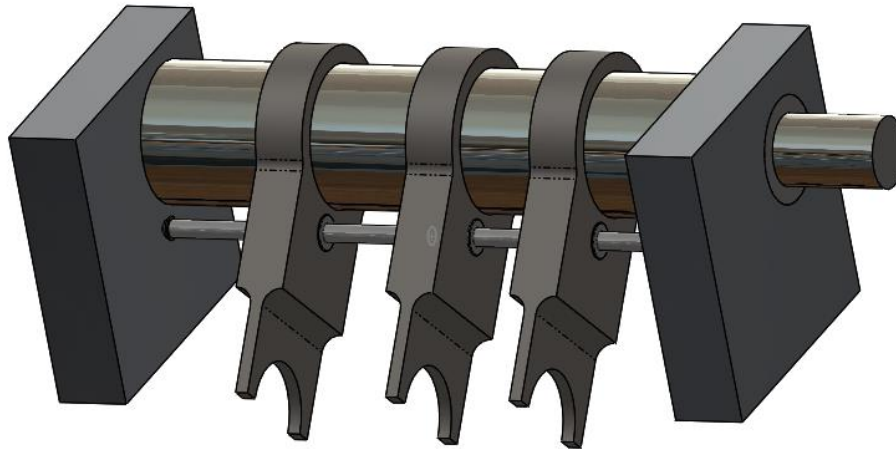

*Figure 7: Addition of Guide Shaft*

## 2.5 Shifter

For the Baja to be functioning and meet the customer requirements of three forward gears, a neutral gear, and reverse, the transmission needed a way to be shifted. The current gear box is a sequential design, which in our case means a gear is shifted with a 30 degree rotation of the shift shaft in the transmission. A shifting mechanism was designed to achieve this and a prototype was 3D printed in the NAU Fabrication Shop. The shifting mechanism was assembled and tested to ensure the geometry met the needs of the transmission. With approval of the design the shifting mechanism was then machined out of mild steel.

## 2.6 Frame

The Figure 8 is from last year's FEA. As shown in Figure 8, there is a mistake in this study. The left member and the right member in the red circle are not connected to each other successfully. When the team was applying the forces to the frame, all forces are acting on the right member, and there is no force acting on the left member. It resulted a quite huge deformation on the right member and the team got an inaccurate factor of safety in this study.



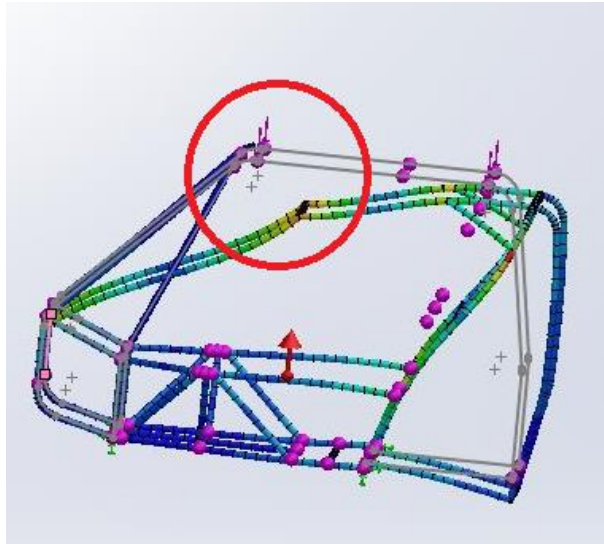

Figure 8: Old FEA Analysis

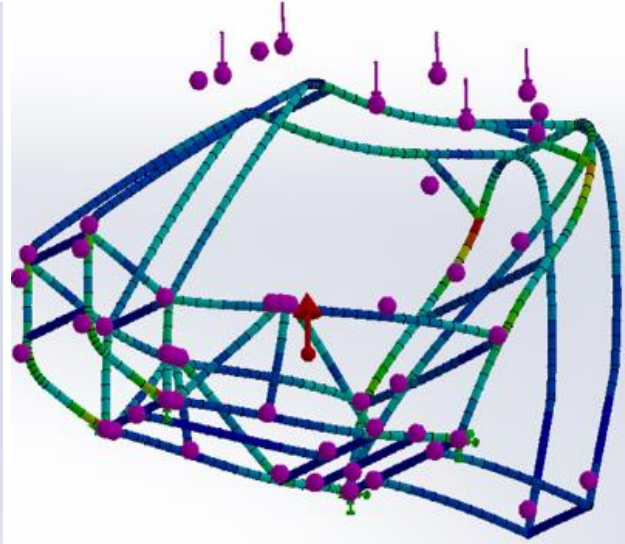

Figure 9: New FEA Analysis

The requirement of factor of safety is 1, since the assumption is based on 25 miles per hour velocity and 0.2 second impact time. This assumption is already an extreme case, and a factor of safety of 1 is therefore justified. The results show that all factors of safety are bigger than 1, the team will not consider to make any other modifications to this frame as long as it satisfies the SAE competition rules. The team fixed solidworks file and connected the members in this semester. As shown in the Figure 9, the deformation is much smaller when applied the same forces. The Table 1 lists the factors.

Table 1: Impact Safety Factors

	Maximum Stress *10 <sup>8</sup> Pa	Yield Stress *10 <sup>8</sup> Pa	Factor of Safety	Factor of Safety Requirement
Front impact	1.551	4.6	2.96	1
Side impact	3.972	4.6	1.158	1
Rear impact	4.092	4.6	1.124	1
Roll over	1.859	4.6	2.470	1

## 3. Current Progress

### 3.1 Muffler

The team has finished the design and the installation of the muffler. With changes mentioned in design modification section, the old exhaust pipe was cut off from the muffler and the flange and a new shortened pipe was welded back to the original muffler and the flange (Figure 10). The muffler now has been securely mounted to the engine (Figure 11) and it is totally within the boundary of the frame. Hence, the current muffler has meet all requirements in SAE Baja rules.

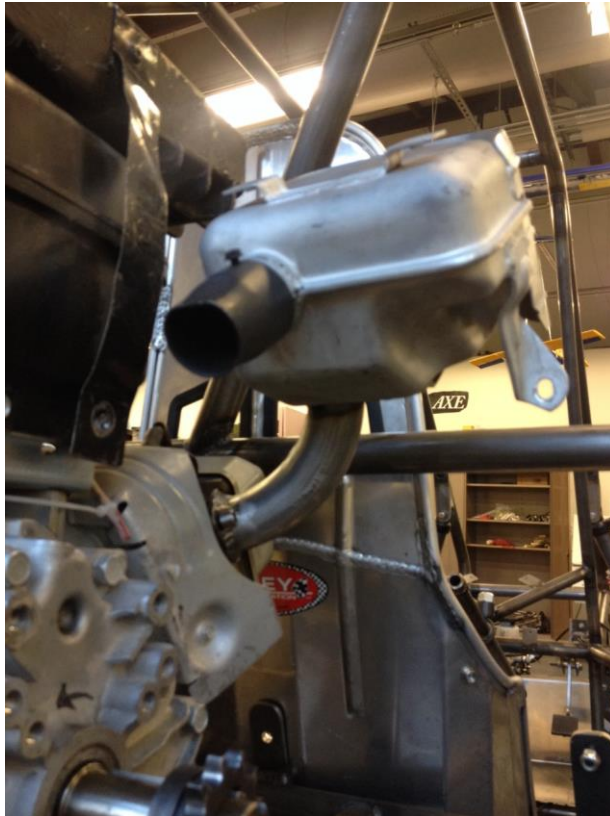

*Figure 10: New Muffler Front View*

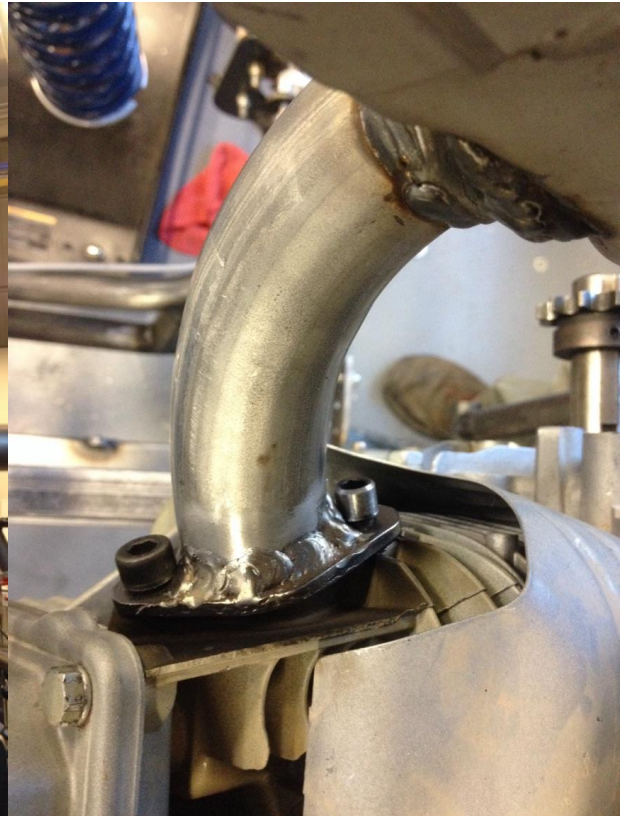
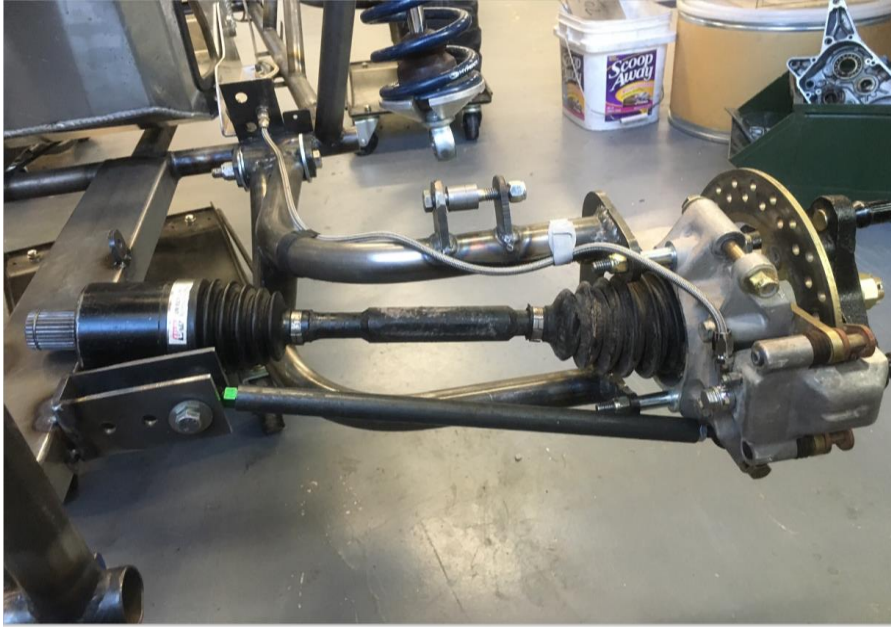

*Figure 11: New Muffler Tubing View*

### 3.2 Rear Suspension

Currently the rear suspension is on the second iteration of the original adjusted design. The first adjustment included an additional two members to be added between the spindle and the frame. The second iteration contains only a single (lower) linkage due to complications on the upper mount. The upper linkage mount proved to be an issue due to the implementation of shifting components which would need the same space. Currently, the single link is mounted to the side of the transmission mount and has a full range of motion which can be seen in Figure 12. Before additional suspension work can be done, the Baja needs to be drivable. Once the Baja is in a drivable condition, the current design can be analyzed and improved upon. Major focal

points for assessment include front bushing stability, mounting bracket stability, any link bending due to over compression and CV shaft movement/play.



*Figure 12: Current two-link Suspension*

### 3.3 Fuel Catchment

The team currently has finished the design stage of the fuel catchment. The next step is to order the sheet metal for fabrication. Once the metal attachment has been fabricated and added to the Baja, the fuel system will need to be tested. Assuming the fuel catchment does not leak and efficiently funnels the fuel without puddling, the new design will pass the applicable regulations and be ready for the competition.

### 3.4 Transmission

The overall redesign of the shift forks and the addition of the guide rod have proven to be successful changes to the overall functionality of the transmission. However in the last shifting test it was discovered that the pins on the reverse collar are partially engaged throughout each gear change, a potentially destructive design issue. After some troubleshooting and looking at the CAD design from last year, it was discovered that the shift fork for the reverse gear must be offset from the center of the fork by  $1/4$ " , the design change is shown in Figure 13. This design change will require a new fork to be milled but should provide the final fix to the design of the transmission. Once this final task is complete, the team will be able to assemble all the components of the transmission, wear the gears, and re-evaluate the transmission for any new changes that should be made.

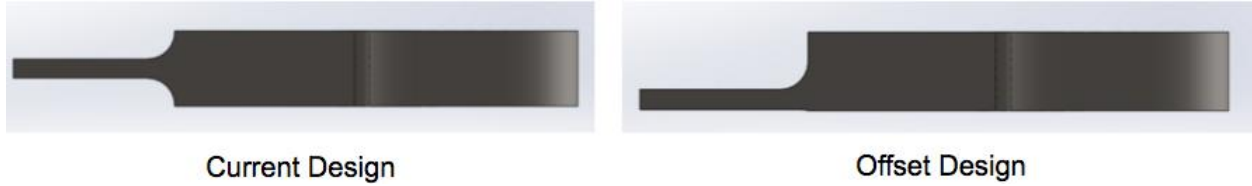

*Figure 13: Fork Designs*

### 3.5 Shifter

As of right now the shifter is in the final stages of production. All the main components of the shifter have been machined and assembled as seen in Figure 14.



*Figure 14: Representation of Shift Mounting*

The final task for the shifting mechanism is to be mounted to the frame. The final position of the shifter is to be determined by the new mounting location of the entire transmission. Once the transmission is mounted to the frame, the bearing location can be determined for proper alignment of the shifting mechanism. The shifting mechanism will be mounted pointing down with a slight angle to avoid interference from the frame and drive chain coming from the engine. The shifter stroke will be initiated by a linkage bar that goes to a shifter beside the driver on the right hand side as seen in Figure 15.

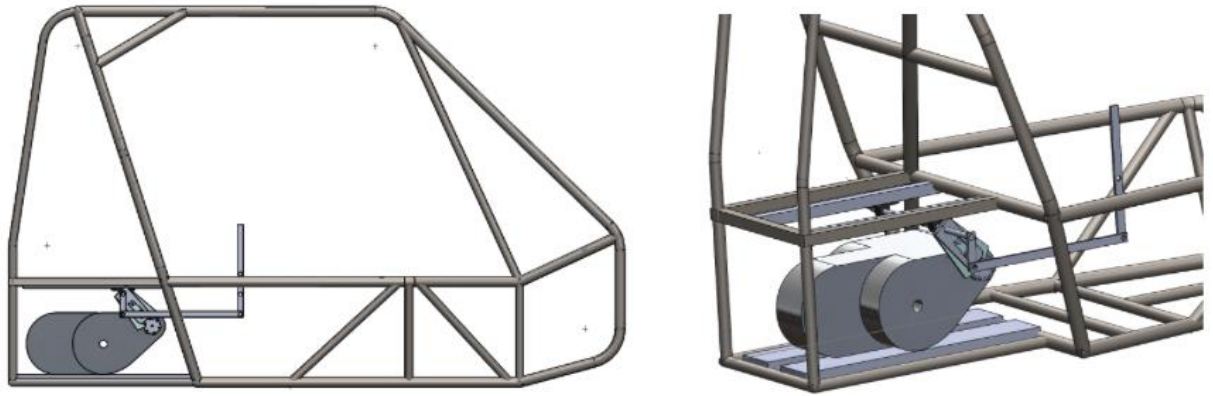

Figure 15: Layout of the Shifter and Transmission

## 4. Updated Project Plan

As shown in Table 2, this is week 24 of the overall project and the team has finished most of the milestones such as redesigning the forks, frame pre-check document and moving the muffler. After the spring break which is the week 25, the team will have two more hardware reviews to finish. Most important, the team has to make sure the Baja is drivable before April 1st, and the team will do a series of tests after the date of April 1st. The team will also focus on the driver training, try to adjust and stabilize the Baja.

Besides the competition, there are still two presentations left for this project. The walkthrough presentation is in week 30 while the UGRADS presentation is in week 31. The final report of the project must be submitted in the week 31. The last task of this project is to make the operations manual, which is due the last week. Table 3 shows how the team will progress throughout the next few weeks to accomplish the final milestones.

Table 2: Milestones to Complete Project

Task	1	2	3	4	5	6	7	8	9	10	11	12	13	14	15	16	17	18	19	20	21	22	23	24	25	26	27	28	29	30	31	32		
Problem Definition and Project Planing				◆																														
Concept Generation and Selection								◆																										
Concept Protopyte												◆																						
Project Proposal															◆																			
Hardware Review 1																					◆													
Hardware Review 2																						◆												
Hardware Review 3																							◆											
Midpoint Review																								◆										
Hardware Review 4																									◆									
Hardware Review 5																										◆								
Make Sure the Baja is drivable																																		
Walkthrough Prensentation																																		
UGRADS Presentation and Final Reports																																		
Operations Manual																																		

Table 3: Progress Schedule

Task	1	2	3	4	5	6	7	8	9	10	11	12	13	14	15	16	17	18	19	20	21	22	23	24	25	26	27	28	29	30	31	32		
Communicate With Client	█	█	█																															
Defining Project ,Need, Goal, Objective and Constraints	█	█	█																															
Preparing Quality Function Deployment:	█	█	█																															
State Of the Art Research	█	█	█																															
Verify The Date of Frame		█	█	█																														
Creating Function Diagramme:			█	█	█																													
Conceptualizing Alternative Approach:				█	█	█																												
Register with SAE					█	█	█																											
Decision Matrices						█	█	█																										
Brainstorming for the transmission							█	█	█																									
Concept Selection:								█	█	█																								
Budget Analysis									█	█	█																							
Engineering Analysis for Improved Baja										█	█	█																						
Fabrcating Concept Protopyte:											█	█	█																					
Testing Concept Protopyte:												█	█	█																				
Order The Engine and Other Necessary Materials													█	█	█																			
Finalizing The Project:														█	█	█																		
Preparing for Hardware Review 1															█	█	█																	
Preparing for Hardware Review 2																█	█	█																
Preparing for Hardware Review 3																	█	█	█															
Preparing for Midpoint Review																		█	█	█														
Preparing for Hardware Review 4																			█	█	█													
Preparing for Hardware Review 5																				█	█	█												
Preparing for Walkthrough Prensentation																					█	█	█											
Preparing for UGRADS Prensentation and Final report																						█	█	█										
Preparing for Operations Manual																							█	█										

## 5. Conclusion

In conclusion the Baja team is anticipating having a drivable Baja that will be ready for testing by April 1. The vehicle will be completed to SAE standards to ensure there is no issues entering the race if registered. For the Baja vehicle to be completed a set of tasks must be addressed by the Baja team. The transmission requires an offset shifting fork to be machined, the shifting mechanism needs to be mounted and aligned, and the rear suspension linkage mounts need to be totally welded to the frame, the fuel catchment addition must be fabricated and mounted to the existing catchment. With these final issues addressed and completed, the Baja will be in the testing phase, which will allow time for the necessary changes to be made for potential competition.

## References

- [1] Erickson, Wallace D. *Belt Selection and Application for Engineers*. New York: M. Dekker, 1987.
- [2] Naunheimer, Harald. *Automotive Transmissions Fundamentals*, Selection, Design and Application. 2nd ed. Berlin: Springer, 2011.
- [3] Sae.org, '2016 Collegiate Design Series Baja SAE Rules', 2016. [Online]. Available: [https://www.bajasae.net/content/2016\\_BAJA\\_Rules\\_Final-9.8.15.pdf](https://www.bajasae.net/content/2016_BAJA_Rules_Final-9.8.15.pdf). [Accessed: 11- March-2016].