

2015-16 SAE Baja

By

Fahad Alajmi, Sean Collins, Peng Li,

Auston Solway, Maximilian Whipple and Jingyuan Zhang

Section 3 Team 13

Final Proposal

Document

*Submitted towards partial fulfillment of the requirements for **Mechanical
Engineering Design I – Fall 2015***



Department of Mechanical Engineering

Northern Arizona University

Flagstaff, AZ 86011

Table of Contents

Table of Tables	i
Table of Figures	i
1. Introduction	1
1.1 Problem Statement	1
1.2 Background	1
2. Problem Statement.....	1
2.1 Problem Definition.....	1
2.2 Design Objectives	2
2.3 Design Constraints	2
3. Quality Function Deployment	3
3.1 Engineering and Customer Requirements.....	3
3.2 House of Quality	3
4. State of the Art.....	5
4.1 Centrifugal Clutch.....	5
4.2 Continuously Variable Transmission (CVT)	5
4.3 Sequential Gearbox	5
5. Function Diagram	5
6. Criteria Analysis	6
6.1 Rear Suspension	7
6.2 Clutch	8
6.3 Shifter.....	9
7. Concept Generation	10
7.1 Suspension.....	10
7.2 Clutch	13
7.3 Shifter.....	13
8. Concept Selection	14
8.1 Suspension.....	14
8.2 Clutch	15
8.3 Shifter.....	16
9. Design Implementation and Progress	18
9.1 Suspension.....	18

9.2	Transmission	19
9.3	Shifting Mechanism	22
10.	Frame Analysis	24
10.1	Modification 1	25
10.2	FEA Analysis for Modification 1	25
10.3	Modification 2	27
10.4	FEA Analysis for Modification 2	28
11.	Designs in Progress	30
11.1	Muffler Design	30
11.2	Throttle Design	30
11.3	Fuel Catchment	30
12.	Bill of Materials	30
13.	Updated Project Plan	32
	References	33

Table of Tables

Table 1: SAE Baja Goals, Objectives, and Constraints	2
Table 2: Quality Function Deployment	3
Table 3: House of Quality	4
Table 4: Criteria Preference Rating	6
Table 5: Example Analytical Hierarchy.....	7
Table 6: Weighted Suspension Criteria	8
Table 7: Weighted Clutch Criteria	9
Table 8: Weighted Shifter Criteria.....	10
Table 9: Criteria Ranking.....	14
Table 10: Raw Score and Criteria Weights.....	15
Table 11: Finalized Weighted Score.....	15
Table 12: Criteria Ranking.....	15
Table 13: Raw Score and Criteria Weights.....	16
Table 14: Bill of Materials	31
Table 15: Updated Gantt Chart	32

Table of Figures

Figure 1: Functional Diagram	6
Figure 2: Single Trailing Arm.....	11
Figure 3: Control Arm.....	11
Figure 4: Three Link Design.....	12
Figure 5: Dry Basket Clutch	13
Figure 6: Centrifugal Clutch	13
Figure 7: Ratchet Shifter	13
Figure 8: Gate Shifter.....	14
Figure 9: CAD Rear suspension.....	18
Figure 10: Three-link Rear Suspension	19
Figure 11: Internal View of Transmission	20
Figure 12: Current Fork Design	21
Figure 13: Former Fork Design	21
Figure 14: Current Shift Rod	21
Figure 15: Proposed Change	22
Figure 16: Sequential Shifting Rod in the Transmission	22
Figure 17: Shifter Rapid Prototype	23
Figure 18: Machined Component for Shifter	23
Figure 19: CAD for Shifter	24
Figure 20: Frame Rules [6]	25
Figure 21: Old Frame CAD (left) Modification 1 Frame (right)	25
Figure 22: FEA Front Impact Result for Modification 1	26
Figure 23: FEA Side Impact Result for Modification 1.....	26
Figure 24: FEA Rear Impact Result for Modification 1	27

Figure 25: FEA Roll Over Result for Modification 1	27
Figure 26: Modification 1 Frame (left) Modification 2 Frame (right).....	28
Figure 27: FEA Front Impact Result for Modification 2	28
Figure 28: FEA Side Impact Result for Modification 2.....	29
Figure 29: FEA Rear Impact Result for Modification 2	29
Figure 30: FEA Roll Over Impact Result for Modification 2.....	30

1. Introduction

Senior Engineering students at Northern Arizona University (NAU), are given a multitude of opportunities to demonstrate their knowledge related to engineering design and practices. One project in particular is the Mini Baja Project sponsored by the Society of Automotive Engineers (SAE) International, and advised by Dr. John Tester. This project in particular demonstrates engineering design and implementation related to the automotive industry through a competition between university groups from across the world.

1.1 Problem Statement

The automotive industry is one of the most competitive and discussed industries in the United States. Constant research and development for new and improved vehicles is required to keep this industry thriving. In order to pursue and develop new technology in an ever-expanding field, it is important to inspire upcoming engineers to learn the concepts related to the automotive industry. The Society of Automotive Engineers has recognized the importance in educating young engineers for the automotive industry and are challenging students from across the world to test their abilities by developing a mini Baja vehicle for a worldwide competition.

1.2 Background

SAE International has had a presence at NAU for 15 years [1]. The following defines the role of SAE International with universities across the world: “SAE International is the leader in connecting and educating engineers while promoting, developing and advancing aerospace, commercial vehicle and automotive engineering” [2]. Since 1976, SAE has sponsored an annual Mini Baja competition, Dr. Tester has served as the advisor to the Mini Baja project at NAU since 2000 [1]. Under Dr. Tester’s advisement the Mini Baja senior capstone group will propose and implement a design for competition as per SAE International rules and regulations.

2. Problem Statement

2.1 Problem Definition

The SAE club, advised by Dr. Tester does not have an operational mini Baja vehicle to compete in the SAE competition. The goals of the SAE mini Baja group, shown in Table 1 is to build an operational Baja vehicle using the frame from last year’s design that will place in the top ten for the SAE competition. In order to be successful the project must serve as a learning opportunity and inspire teamwork related to engineering design and practices.

Table 1: SAE Baja Goals, Objectives, and Constraints

Goals	Objectives	Constraints
Make Design Operational	Increase Acceleration	Fully Operational March 1, 2016
Learning Opportunity	Increase Speed	Minimum 2 forward gears and 1 reverse
Inspire Teamwork	Make Lightweight	Maximum 108" in length and 64" in width
Re-use Frame	Improved Traction	Weigh between 400 and 800 lb
	Make Safer	10 hp Briggs and Stratton engine
	Increase Ergonomic Capacity	

2.2 Design Objectives

To accomplish our goal of placing in the top ten at competition, the SAE Baja team has established multiple objectives related to the performance of the vehicle. Based on the current state of the Baja from last year's design, the mini Baja group wants to increase the speed and the acceleration of the vehicle by improving the performance of the transmission. In order for the vehicle to be competitive the group wants to decrease the weight of the vehicle and improve the traction. Finally, group also wants to make the vehicle safer while also expanding the ergonomic capacity for the driver.

2.3 Design Constraints

From our objectives, and under the advisement of Dr. Tester, the team agreed on multiple constraints that will help guarantee the Baja's success. To ensure completion and to provide adequate time for testing, the group must have a fully operational vehicle by March 1. Additionally, this fully operational Baja must utilize a minimum of two forward gears and one reverse gear, must incorporate a standard 10 hp Briggs and Stratton engine, and cannot exceed 108 inches in length or 64 inches in width. In order to be competitive, the team is hoping to have a vehicle weight between 400 and 800 pounds.

3. Quality Function Deployment

3.1 Engineering and Customer Requirements

Given our objectives and constraints, the group was able to create a Quality Function Deployment, by developing a set of customer and engineering requirements, this can be found in Table 2. These will influence our design choices while completing the mini Baja. In addition, the Quality Function Deployment helps us see the relationships between customer needs and engineering requirements to make our mini Baja competitive. Through our QFD we found that the transmission, dimensions, factor of safety, and body weight are the most important engineering requirements that we want to focus on for our design.

Table 2: Quality Function Deployment

Engineering Requirements \ Customer Requirements	Young's Modulus	Body Weight	Transmission	Dimensions	Frame Thickness	Factor of Safety	Total Cost	Exhaust Pipe Length	Engine Power	Spring Stiffness	Velocity	Maximum Steer Angle
Follow the 2016 SAE Baja Rules		9	9	9				9	9			
Safety	9				9	9						9
Inexpensive	9	9		9	9		9			9		
Aesthetic				3	3			1				
Maneuverability	9	9	9	1	1				9	9	9	9
Ergonomic Cockpit				3								
Traction		9	9	9					9			9
Robust	9			3	9		3			9	9	9
Endurance	9	9			9	9	1			3		9

Legend	
Strong Relationship	9
Moderate Relationship	3
Weak Relationship	1

3.2 House of Quality

The House of Quality (Table 3) shows the correlation of each functional requirement in reference to the other function requirements. By referencing these to each other we are not only able to see

how they will directly impact each other but how influential they are to the project as a whole. For example Young's Modulus will be positively impacted by the thickness of the frame while causing the safety factors as well as the overall price to go. The dimensions of the Baja affect the bodyweight of the cart. As the frame thickness and factor of safety rise with the body weight the speed is affected negatively which should analyzed during the build. The negative correlation between the body weight and the transmission is due to the added stress that will be put on the transmission therefore causing a lower output efficiency. The transmission has a strong correlation with the speed of the Baja because it is the direct linkage between the power output and movement. The dimensions of the cart are proportional to the frame thickness, exhaust pipe, as well as the overall cost. As the frame thickness is adjust the pricing of the project will change drastically. Although not initially guessed as a correlation, the stiffness of the suspension used affects the overall cost of Baja, but more importantly the safety factor. A more expensive suspension design will cost more but will keep the driver safe while in a competition that is based off road with large obstacles and drop-offs. Last but not least, the engine power, used in conjunction with the transmission, proportionally affects the speed of the Baja, which is crucial during the main races of the Baja competition.

Table 3: House of Quality

Young's Modulus													
Body Weight													
Transmission		-											
Dimensions		+											
Frame Thickness	-	+		+									
Factor of Safety	+	+			+								
Total Cost	+	+		+									
Exhaust Pipe Length				+									
Engine Power								+					
Spring Stiffness								+	+				
Velocity													
Maximum Steer Angle		-	+									+	
Engineering Requirements	Young's Modulus	Body Weight	Transmission	Dimensions	Frame Thickness	Factor of Safety	Total Cost	Exhaust Pipe Length	Engine Power	Spring Stiffness	Velocity	Maximum Steer Angle	
Column#	1	2	3	4	5	6	7	8	9	10	11	12	
Direction of improvements	↑	0	↑	0	0	↑	↓	0	0	↑	↑	↑	

4. State of the Art

Due to the multiple features on the mini Baja there are many state of the art components to analyze. However, the only factor currently disabling the Baja is due to the transmission, therefore the capstone group has chosen to focus our state of the art research on improving the functionality of the transmission to get the Baja in working order.

4.1 Centrifugal Clutch

Uses a centrifugal spring mechanism to engage the motor with the drivetrain [5]. The centrifugal clutch is the simplest and cheapest of all the options. This clutch mechanism has many drawbacks. The clutch wears out very fast with higher horsepower motors such as the mandatory 10 horsepower one we are using. The clutch also restricts the Baja to one gear ratio.

4.2 Continuously Variable Transmission (CVT)

The CVT uses belt driven pulley mechanisms to engage the engine to the drivetrain [3]. The CVT is slightly more complex than the centrifugal clutch, but is more applicable for our application. The CVT changes gear ratios as the Baja increases speed. The CVT is also automatic and doesn't have to be shifted into gear. Some drawbacks of this transmission are, high torque causes heat and belt damage [4], the driver can't select a certain gear ratio for an event, large amounts of slippage if any fluids get on the belt.

4.3 Sequential Gearbox

Our team has decided that the sequential gearbox is the best choice for the Baja. The gearbox allows us to have a selection of drive and reverse gear ratios. We can implement a low gear ratio for acceleration and hill climb testing. It will also allow for higher ratios for the endurance and suspension test. This gearbox is also filled with fluids to keep the friction and heat down [5]. It is also serviceable with common supplies at any auto parts store. Some drawbacks of this transmission is that the gears are custom machined and the driver needs an understanding of using hand clutch and shifting levers while driving and maneuvering the course.

5. Function Diagram

The function diagram (figure 1) shows the correlation of different main parts of the Baja and the energy flow between those parts. From the diagram, energy flow in is provided by human, gasoline and battery power. The engine transfer the chemical energy gained from combusting gasoline into mechanical energy. After that, the energy goes into clutch, transmission, differential and finally the wheels. The wheels support the suspensions and the frame. In addition, the power provided by battery goes to reverse light and brake light which are used for informing others.

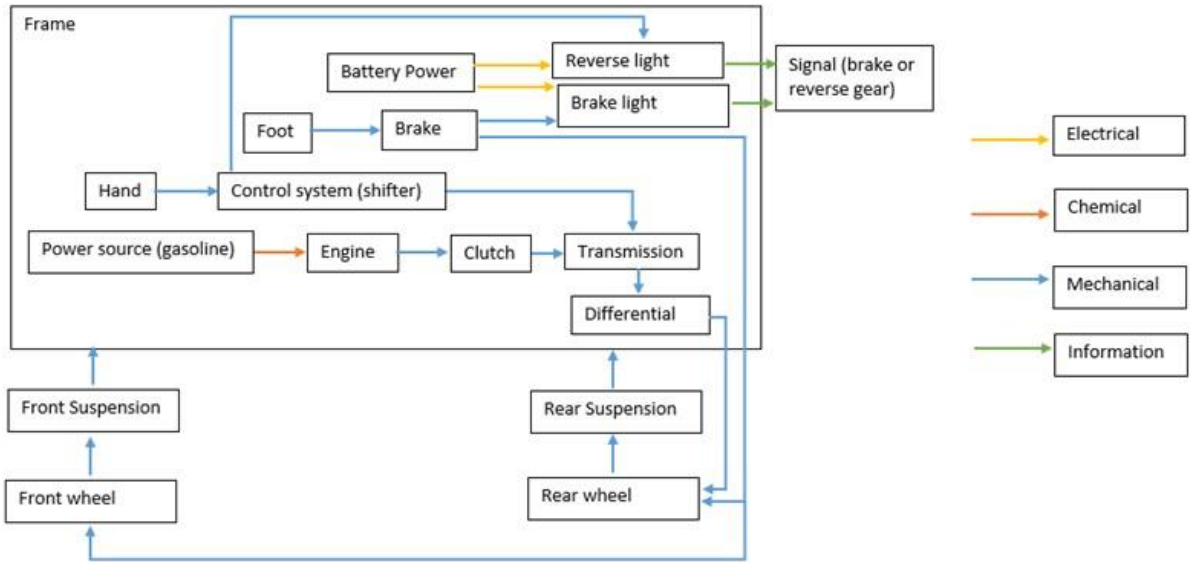

Figure 1: Functional Diagram

6. Criteria Analysis

When selecting important components to incorporate into the construction of the Baja, multiple criteria should be chosen for each component based on the part’s functionality. These criteria should then be weighted based on their importance to the operation of the system. The overall weight of each criterion is then used for the final calculation of the decision matrix. When analyzing the criteria for each concept, the analytical hierarchy process was used, an example of this is shown in the tables below. Each group member individually rated criteria, this was done by deciding if the criteria in the row was more important than the criteria in the column, if so a whole numeric value from Table 4 was selected based on the objective opinion of each member. If it was determined that the column is more important than the row, a fraction was inserted into the cell. The final result is then normalized to express the weight of the criteria; the entire process is shown in Table 5. Since each group member analyzed the criteria for each concept, only the average weighted values for each subsection of criteria analysis are shown. Table 2 only demonstrates how each team member weighted the criteria.

Table 4: Criteria Preference Rating

Preference	Rating
Extremely Preferred	9
Very Strongly Preferred	7
Strongly Preferred	5
Moderately Preferred	3
Equally Preferred	1

Table 5: Example Analytical Hierarchy

Criteria	Durability	Main. /Repair	Weight	User Friendly	Cost	Total	Norm. Weight
Durability	1	7	3	1/5	3	14.20	0.28
Maint./Repair	1/7	1	1/5	1/3	3	4.68	0.09
Weight	1/3	5	1	3	1/5	9.53	0.18
User Friendly	5	3	1/3	1	1/7	9.48	0.18
Cost	1/3	1/3	5	7	1	13.67	0.27
Total	6.81	16.33	9.53	11.53	7.34	51.55	1.00

6.1 Rear Suspension

The team chose multiple criteria to analyze for the selection of a rear suspension for the Baja vehicle. In order for the vehicle to be competitive in a racing setting, multiple factors must be taken into account, the factors chosen for analysis are: length of travel, deflection, durability, cost, and maintenance/repair.

Length of travel in this context refers to the amount the rear suspension is able to move along the y-axis when combined with shock absorption. In race competitions such as the endurance race and suspension test, length of travel is an important factor because it helps to protect the safety of the driver and the vehicle from jarring impacts. Additionally, when traversing over uneven terrain, jumps, and drops, length of travel also affects the handling of the vehicle.

Deflection is another important factor to consider regarding suspension selection. Deflection refers to the maximum amount of movement in the x-axis. Since the transmission of power between the differential and the wheels occurs through CV axles, the amount of deflection should be as limited as possible. When too much deflection occurs in this system, the CV joints and the bearings that connect them to the transmission experience stresses unintended for their application, ultimately causing failure in the CV axle or the bearing connecting them to the transmission.

In the context of a racing environment, durability is measured in the amount of hours the suspension should be able to withstand constant abuse before critical failure occurs. Since the race involves traversing rough terrain for a long period of time, durability was chosen as an important factor for analysis. Another factor closely associated with durability is maintenance and repair, referring to the ideal amount of time required to fix a minor malfunction in the suspension during a race.

The final criterion for analysis is the cost associated for building the rear suspension. Cost takes into account the amount of money required to purchase materials and the labor involved in building the suspension.

Table 6 shows the average final weighted criteria for the suspension.

Table 6: Weighted Suspension Criteria

Criteria Weight	
Criteria	Average Weight
Travel	0.14
Deflection	0.13
Durability	0.37
Cost	0.12
Maint./Repair	0.24
Total	1.00

6.2 Clutch

Providing the transmission of power between the engine and the transmission, the clutch serves a very important role in the drivetrain system. The criteria chosen for analysis include: durability, maintenance/repair, starting torque, user friendly, and cost.

Similarly to the durability for suspension, durability in this context refers to the predicted amount of hours the clutch should be able to withstand before failure. Additionally, maintenance and repair also refers to the amount of time needed to replace components and get the clutch in working order during a race.

The next important criterion to analyze is the torque the clutch is able to withstand, especially when a vehicle is at a dead stop. If the output torque is too high when engaging with the transmission, the clutch could potentially break. Thus, determining a clutch that will withstand the required starting torque is necessary when purchasing.

One of the most limiting factors regarding clutches is the cost associated with the various types of clutches. Based on the type of clutch and the quality, will determine what kind of clutch will be reasonable to purchase, this is important due to the limited budget the team has access to.

The final criteria to analyze is how user friendly the clutch is, this limitation mostly applies to the driver. Depending on the clutch that is chosen will depend on the ease of use the user will experience when operating the clutch. In the setting of a race, when gear shifts occur often, this is important so that the driver does not stall the vehicle, causing the vehicle to stop mid-race.

Table 7 shows the group final weighted criteria for the clutch.

Table 7: Weighted Clutch Criteria

Criteria Weight	
Criteria	Average Weight
Durability	0.30
Maint./Repair	0.12
Torque	0.21
User Friendly	0.13
Cost	0.24
Total	1.00

6.3 Shifter

The current transmission in the Baja vehicle possesses four forward gear and one reverse gear; however, the main limitation with the current set-up is that the transmission is unable to shift between gears. As a result, it is the responsibility of this year's Baja team to design and develop a working shifting mechanism for the transmission to operate to full capacity. The following criteria for the shifter we have chosen to analyze are: degrees of throw, shifting speed, shifting force, cost, and simplicity.

Degrees of throw refers to the amount degrees from the shifting handle required to shift the transmission one position in the gear box. Due to the physical restraints the driver will be experience while in the cockpit of the vehicle, the degrees per shift should be as limited as possible.

Shifting speed is an important factor since the driver will have to shift between gears often, especially when the driver is forced to a dead stop and must transition the gearbox back to the beginning gear. This is especially important since the type of gearbox on the vehicle is a sequential gearbox, meaning gears must be shifted in order and none can be skipped; for example, when shifting from fourth gear to first gear, the driver must shift through third and then second. Shifting force is a criterion that affects the speed at which the driver can shift. The amount of torque required to turn the shifting rod on the transmission will determine how the shifting mechanism will be designed thus determining the force required from the driver to shift the rod one position.

Like the suspension and the clutch, cost is another important factor in the selection of a shifting mechanism. Depending on if the shifter can be built using raw materials or if the group must purchase a prefabricated shifter will also play an important role in the selection and overall cost of the shifter.

The final criterion to consider is the simplicity of the shifting mechanism, ideally the team would like to design and build, or buy a shifting mechanism with as many little parts as possible. Not only does simplicity reduce the amount of time required to maintain/repair the mechanism, it also

reduces the complexity involved in the building of the mechanism if the group chose to construct their own shifter.

Table 8 shows the average final weighted criteria for the shifting mechanism.

Table 8: Weighted Shifter Criteria

Shifter	
Criteria	Normalized Weight
Degrees of Throw	0.18
Shifting Speed	0.13
Shifting Force	0.45
Cost	0.15
Simplicity	0.09
Total	1.00

7. Concept Generation

7.1 Suspension

The rear suspension of the Baja is a focal point due to its failure with its current design. Currently there is an issue with the amount of movement that the arm has in the x direction. After narrowing down the design possibilities of the rear suspension, the team has concluded on three possibilities for further assessment. The possible suspension designs include a single trailing arm, control arm (A-Arm), and a three-link system. Each system has their own positive and negative attributes, which will be further evaluated using decision matrices. These matrices average out each team member's opinion of how influential each design pro/con is. With our current drivetrain design, the Baja has an independent rear suspension. This means that there is no fixed link between the two rear wheel hubs which allows for each side to move independently of the other. This is in comparison to a straight axle design that utilizes a fixed member between the hubs to cause them to move independently of each other. With the independent suspension design both sides and the suspension mirror each other.

The first design choice is referred to as the single trailing arm. The single trailing arm is best described as a single member attached to the rear of the frame connecting the frame to the wheels' hub. This member runs roughly the last third of the overall length and is attached to the frame using a simple bolt through bushing attachment. This attachment design allows for the trailing arm to freely move in the y-direction while the shock absorber, which is attached to the end of the trailing arm, absorbs all of the force acting on the wheel. A large benefit of this design is that it allows for maximum suspension travel. One issue with this design is that it allows max deflection in the x-direction due to lack of restricting linkages. This means that any force acting in the x direction on

the wheel of the Baja, would cause the trailing arm to act as a cantilever with only the fixed bushing to absorb the torsional force. Through experimentation, it was found that these forces cause the attaching bracket to bend and therefore causing the overall alignment of the rear wheels to fall out of tolerance.



Figure 2: Single Trailing Arm



Figure 3: Control Arm

Another design possibility is the Control Arm style suspension. This style can also be referred to as an A-Arm style suspension due to the shape of each control arm. A control arm suspension utilizes an upper and lower control arm to attach the wheels hub to frame. The upper and lower control arms both attach to the frame using the same bolt through bushing design. Each control arm has two connecting junctions totaling to four per wheel. Due to the increased amount of connections to the frame the reduction of deflection due to the cantilever movement is assumed to

decrease. One positive aspect to this design is that it also takes into consideration the vertical angle of the wheel in comparison to the surface it is driving on. This means that the wheel is able to be stay vertical, in reference to a ground, longer due to the utilization of ball joints. Ball joints are joints that work similar to a ball and socket joint found on a human being. A ball joint is located at the end of each control arm to connect the hub and allows for the wheel to have a slight change of angle as the wheel moves up and down with the terrain. Another positive feature to this design is the cost of manufacturing. The manufacturing cost of each control arm is relatively low in comparison to other styles. A negative feature of this design is that it does not have the same suspension travel capabilities as other designs.

The third design that the team has narrowed down to is the Three Link style suspension. The three-link suspension style is named in reference to the amount of members connecting the hub, or in other cases the axle, to the frame of the Baja. In our case of the independent rear suspension, one of the three links in the system is the trailing arm. As previously mentioned the trailing arm connects the frame of the Baja but in this case utilizes a different connection style.

The previous explanation of the a trailing arm system uses a bolt through bushing style as the connection while the three link system utilizes a hemi joint in order to allow for a slight rotation in the trailing arm as the suspension contracts. A hemi joint is pivot style bearing and is placed at the end of each link. Other than the adjustment in connection style the three link system also adds two members between the hub and the frame in order to minimize the deflection in the x-direction. The additional two linkages are placed perpendicular to the trailing arm. A downfall to this suspension style is that its geometry causes the wheel to change its vertical orientation as the suspension contracts. This suspension will allow for the max suspension travel which is beneficial to the Baja design.



Figure 4: Three Link Design

7.2 Clutch

For the concept generation we narrowed the clutch selection down to a dry basket clutch and a centrifugal clutch. The dry clutch is a user-activated clutch that disengages power from the motor to the transmission.

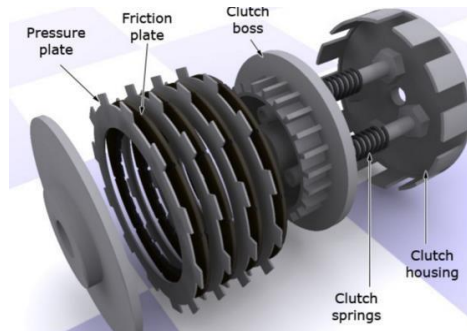

Figure 5: Dry Basket Clutch

The centrifugal clutch is an automatic style-disengaging clutch. It uses the motors decrease in rotations per minute to automatically disengage power from the motor to the transmission.



Figure 6: Centrifugal Clutch

7.3 Shifter

For the concept generation of the shifter we narrowed it down to a ratchet shifter and a gate shifter. The ratchet shifter uses a ratcheting mechanism to shift one gear position with each full throw of the shifter.



Figure 7: Ratchet Shifter

The gate shifter uses precise gates to regulate each shift of the transmission, one full throw of the shifter hits all gears on the transmission.



Figure 8: Gate Shifter

8. Concept Selection

When ranking criteria for each concept, we used a scale from 1-10 in relation to quantifiable values for each criterion. The raw scores for each criterion in each design option is then multiplied by the weighted criteria values shown in section 3. The criteria ranking and decision matrices are shown in their respective subsections.

8.1 Suspension

Table 9 shows the criteria ranking based on quantifiable values for the following criteria for the suspension: travel, deflection, durability, cost, and maintenance/repair.

Table 9: Criteria Ranking

Rear Suspension						
Level	Rating	Travel (in)	Deflection (in)	Durability (hours)	Cost	Maint./Repair (min)
Perfect	10	20	0	30	≤ \$150	≤ 15
Excellent	9	18	0.25	27	\$300	30
Very Good	8	16	0.5	24	\$450	45
Good	7	14	0.75	21	\$600	60
Satisfactory	6	12	1	18	\$750	75
Adequate	5	10	1.25	15	\$900	90
Tolerable	4	8	1.5	12	\$1,050	105
Poor	3	6	1.75	9	\$1,200	120
Very Poor	2	4	2	6	\$1,350	135
Inadequate	1	2	2.25	3	\$1,500	150
Useless	0	0	≥ 2.5	0	> \$1500	> 150

The team as a whole objectively ranked the criteria for each design option, creating raw scores for each criteria (Table 10), these raw scores were then multiplied by the weighted values, resulting in the final weighted score for the suspension options (Table 11).

Table 10: Raw Score and Criteria Weights

Criteria	Three Link	Single Trailing Arm	A-Arm
Travel	10(0.14)	10(0.14)	6(0.14)
Deflection	8(0.13)	0(0.13)	8(0.13)
Durability	7(0.37)	3(0.37)	7(0.37)
Cost	6(0.12)	10(0.12)	7(0.12)
Maint./Repair	6(0.24)	8(0.24)	5(0.24)

Table 11: Finalized Weighted Score

Criteria	Three Link	Single Trailing Arm	A-Arm
Travel	1.4	1.4	0.84
Deflection	1.04	0	1.04
Durability	2.59	1.11	2.59
Cost	0.72	1.2	0.84
Maint./Repair	1.44	1.92	1.2
Total	7.19	5.63	6.51

Based on the information presented in Table 11, the Baja team determined that the three-link suspension is the best option

8.2 Clutch

Table 12 shows the criteria ranking based on quantifiable values for the following criteria for the clutch: durability, maintenance/repair, starting torque, and cost.

Table 12: Criteria Ranking

Clutch					
Level	Rating	Durability	Maint./Repair	Torque (ft-lb)	Cost
Perfect	10	100 hrs.	≤ 15 min.	≥ 30	≤ \$150
Excellent	9	90 hrs.	30 min.	28.5	\$300
Very Good	8	80 hrs.	45 min.	27	\$450
Good	7	70 hrs.	60 min.	25.5	\$600

Satisfactory	6	60 hrs.	75 min.	24	\$750
Adequate	5	50 hrs.	90 min.	22.5	\$900
Tolerable	4	40 hrs.	105 min.	21	\$1,050
Poor	3	30 hrs.	120 min.	19.5	\$1,200
Very Poor	2	20 hrs.	135 min.	18	\$1,350
Inadequate	1	10 hrs.	150 min.	16.5	\$1,500
Useless	0	0 hrs.	> 150 min.	≤ 15	> \$1500

The team as a whole objectively ranked the criteria for each design option, creating raw scores for each criteria (Table 13), these raw scores were then multiplied by the weighted values, resulting in the final weighted score for the clutch options (Table 14).

Table 13: Raw Score and Criteria Weights

Criteria	Centrifugal	Basket Clutch
Durability	7(0.30)	10(0.30)
Maint./Repair	10(0.12)	2(0.12)
Torque	10(0.21)	10(0.21)
User Friendly	10(0.13)	5(0.13)
Cost	9(0.24)	3(0.24)

Table 14: Finalized Weighted Score

Criteria	Centrifugal	Basket Clutch
Durability	2.1	3
Maintenance/Repair	1.2	0.24
Torque	2.1	2.1
User Friendly	1.3	0.65
Cost	2.16	0.72
Total	8.86	6.71

Based on the information presented in table 14, the Baja team determined that the centrifugal clutch is the best option.

8.3 Shifter

Table 15 shows the criteria ranking based on quantifiable values for the following criteria for the shifting mechanism: rating, degrees of throw, shifting speed, shifting force, and cost.

Table 15: Criteria Ranking

Shifter					
Level	Rating	Deg. of Throw	Shifting Speed (s)	Shifting Force (lb)	Cost
Perfect	10	<10	1	<4	≤ \$100
Excellent	9	10	2	4	\$125
Very Good	8	20	3	6	\$150
Good	7	30	4	8	\$175
Satisfactory	6	40	5	10	\$200
Adequate	5	50	6	12	\$225
Tolerable	4	60	7	14	\$250
Poor	3	70	8	16	\$275
Very Poor	2	80	9	18	\$300
Inadequate	1	90	10	20	\$325
Useless	0	>90	> 10	>20	>\$325

The team as a whole objectively ranked the criteria for each design option, creating raw scores for each criteria (Table 16), these raw scores were then multiplied by the weighted values, resulting in the final weighted score for shifting mechanism options (Table 17).

Table 16: Raw Score and Criteria Weights

Criteria	Ratchet	Gate
Degrees of Throw	4(0.18)	8.5(0.18)
Shifting Speed	5(0.13)	5(0.13)
Shifting Force	7(0.45)	4(0.45)
Cost	3(0.15)	10(0.15)
Simplicity	4(0.09)	8(0.09)

Table 17: Finalized Weighted Score

Criteria	Ratchet	Gate
Degrees of Throw	0.72	1.53
Shifting Speed	0.78	0.65
Shifting Force	3.15	1.8
Cost	0.45	1.5
Simplicity	0.36	0.72
Total	5.46	6.2

Based on the information presented in table 17, the Baja team determined that the gate shifter is the best option. However, further tests and analyses will need to be performed later to verify this selection.

9. Design Implementation and Progress

9.1 Suspension

After the decision was made to use the three link system, the first step was to design the new linkages and control arms. During the early stages of the design, the idea was proposed to use the suspension off of a previous Baja which would save both time and money. To test this proposal, the first step was to alter the current CAD design by interchanging the rear suspension members. This also gives the team a reasonable representation of how accepting the new design will be with current frame. The CAD design adjustments supported the idea of using the older equipment by allowing an almost direct replacement which is represented in Figure 9.

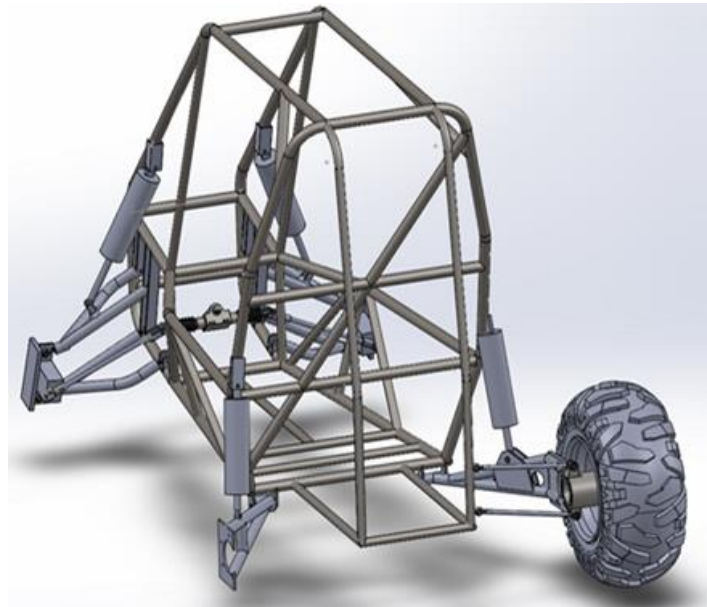

Figure 9: CAD Rear suspension

The next step in the process was to physically take the parts off of the previous Baja and swap them with the current Baja. In doing so the team realized that the swap was not going to be as simple as previously hoped but instead the frame was going to need additional fabrication to accept the implant. The major adjustments included the mounting bracket of the new trailing arm, mounting location of the transmission, overall length of the three link members, as well as a possible change in length of the CV shafts. The new trailing arm utilizes a heim joint instead of the bolt through bushing design which allows for a smaller mount to the frame. The mount will be relocated for the correct alignment of wheel as well as narrowed for the new joint style. The next alteration needed to accept the new suspension was the relocation of the transmission. The current transmission

location had the CV shafts at a drastic angle which causes premature wear within the joint. This had already been established as a problem that needed addressing so the decision was made to shift the transmission forward. The tabs were deleted and the transmission was shifted towards the rear of the Baja as much as possible while still allowing it to pass the frame analysis requirements. This allowed for the new placement of the trailing arm as well as creating a much better CV shaft angle which will prolong the life of the shafts. This adjustment in CV angle can be seen in figure 10. This relocation of the transmission is expected to also allow for the reuse of the current CV shafts without having to purchase new ones. The last stage of the mockup was to compare the current lengths of the three link members to the desired lengths. It was found that the members needed to be shortened in order to provide the ideal suspension angles.



Figure 10: Three-link Rear Suspension

From the initial mockup, the next step was to make the adjustments previously mentioned as well as making new mounting brackets. These adjustments and brackets are currently being designed. After their design, all the new design aspects, including brackets and link lengths, will be converted from their drawings to the machining process. After the machining process has been completed the newly designed rear suspension members will be installed and further analyzed for any additional adjustments needed.

9.2 Transmission

As mentioned earlier, the transmission for this vehicle shifts sequentially, meaning all gears are achieved in sequential order. Figure 11 below shows a picture of some of the internal components when the transmission is assembled. In this figure the parts of primary importance are: the shift rod, the input shaft, the shift forks, and the shift collars. The shift rod is a steel rod with three grooves cut into it, between these three grooves, the transmission has the capability of achieving three forward

gears, a reverse gear and a neutral position. The input shaft contains the gears for this transmission, when power is supplied to the transmission from the engine the input shaft is turned by a chain that connects the two. In order to engage the gears, shifting forks and shifting collars are utilized. The shifting collars are located on the input shaft and slide depending on the input from the shift rod, allowing the collar to engage with a gear. The shifting fork is used to connect the shift rod to the shift collar, allowing inputs from the shift rod to occur.

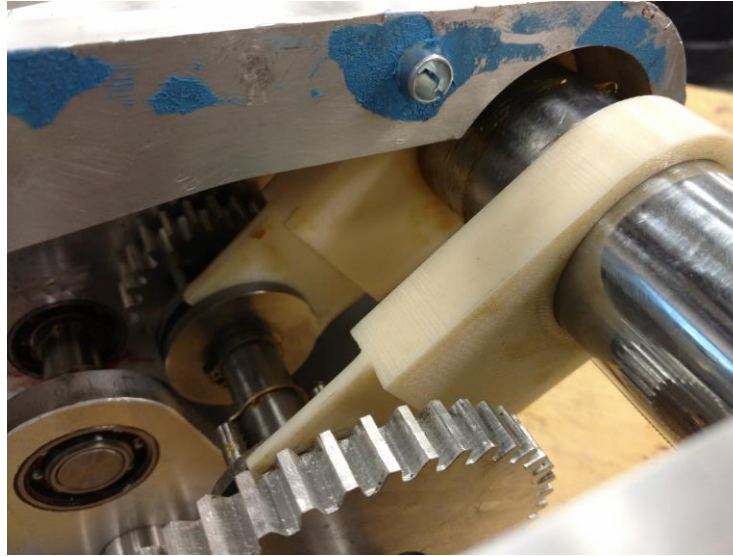

Figure 11: Internal View of Transmission

In the initial stages of the transmission assembly, the group discovered that the shift forks built by the team last year were incompatible with the design of the transmission. The group determined that the three shifting forks were of different sizes, thus when attempting to assemble the transmission, the shift rod and the input shaft would not fit into the bearings of the case because two forks were of improper length and width. The group concluded that this was possibly the result of the shift forks being made from two separate pieces and then welded together. Although this saves time in the machining process the dimensions were possibly wrong due to an improper fit of the two pieces, heat causing the steel to warp, or improper measurements during initial design. As a result, accurate measurements were made for the design of new shift forks; this new design is shown in Figure 12 and is compared to the former design in Figure 13. In order to test the fit, two forks were 3D printed and fit onto the two shafts before beginning the machining process. The forks resulted in a good fit, and one shift fork was manually machined using 1018 steel stock. The other two forks for this application will be machined on a CNC mill towards the beginning of next semester, the G-code will be written and tested over the winter break.



Figure 12: Current Fork Design



Figure 13: Former Fork Design

After test fitting the transmission with the newly milled shift fork and the two 3D printed shift forks, the group encountered a new shifting problem. This problem is a result of the shifting rod. The grooves cut into the shifting rod are very narrow in comparison to shifting rods of current sequential gearboxes; as a result, the pins that follow the grooves tend to catch on the corners of the grooves. Due to this issue, group has determined that the best course of action would be to slightly widen the grooves and increase the radius of the corners. The proposed changes are given in the figures below.

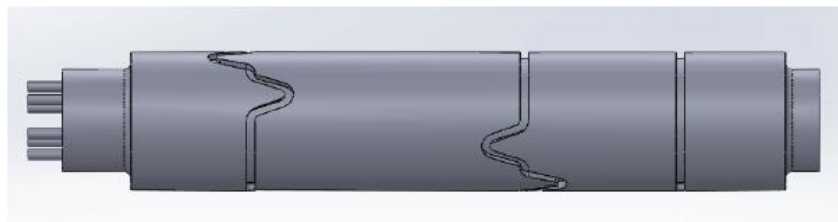

Figure 14: Current Shift Rod

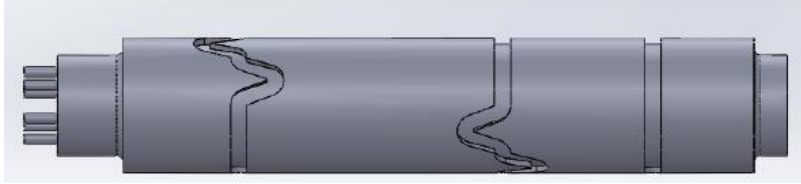

Figure 15: Proposed Change

In order to test the change however, the team will perform an experiment on a 3D printed rod that was printed as a prototype for last year to see if changing the groove width and increasing the corner radii will help with shifting. The machining of this steel part will be difficult, since it will have to be done on a CNC machine with a fourth (rotary) axis. Due to the difficulty of this process, it is highly important to find out exactly what is causing the shifting problem.

9.3 Shifting Mechanism

9.3.1 Sequential Shifter

The sequential shifting rod in the transmission cycles through a gear with each 60 degree rotation. The shifter was designed to shift one gear per throw of the shifting handle. The initial design and geometry was worked out in Solidworks (Figure 16).

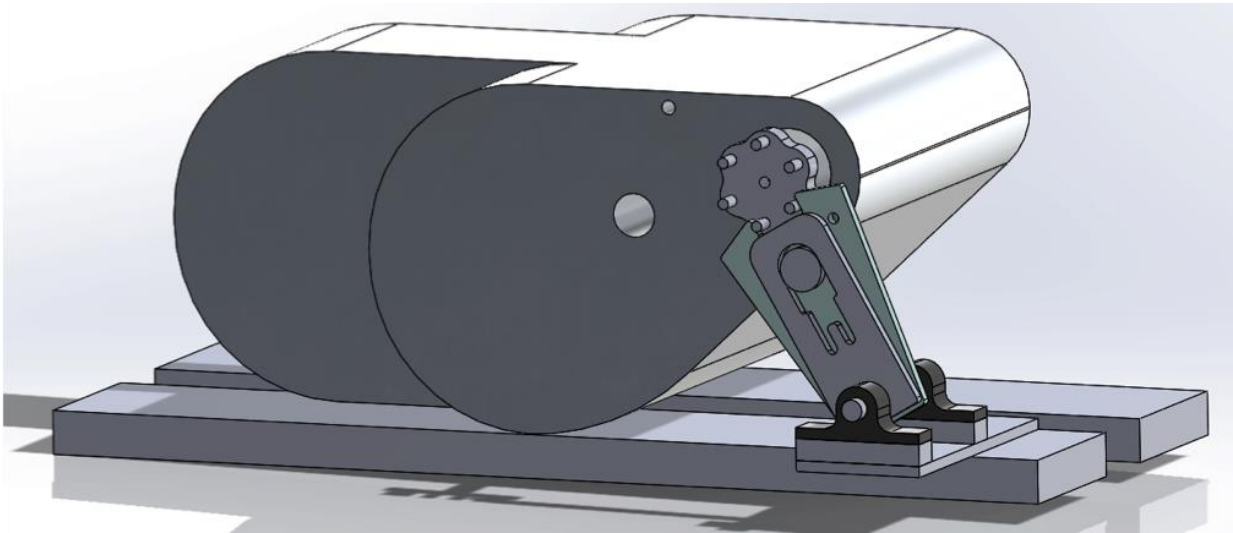

Figure 16: Sequential Shifting Rod in the Transmission

After the Solidworks model was finalized, the design was rapid prototyped to verify that this design was going to work for our application. The rapid prototype was then mounted to a stand to simulate mounting to the frame and shifting through each gear (Figure 17).

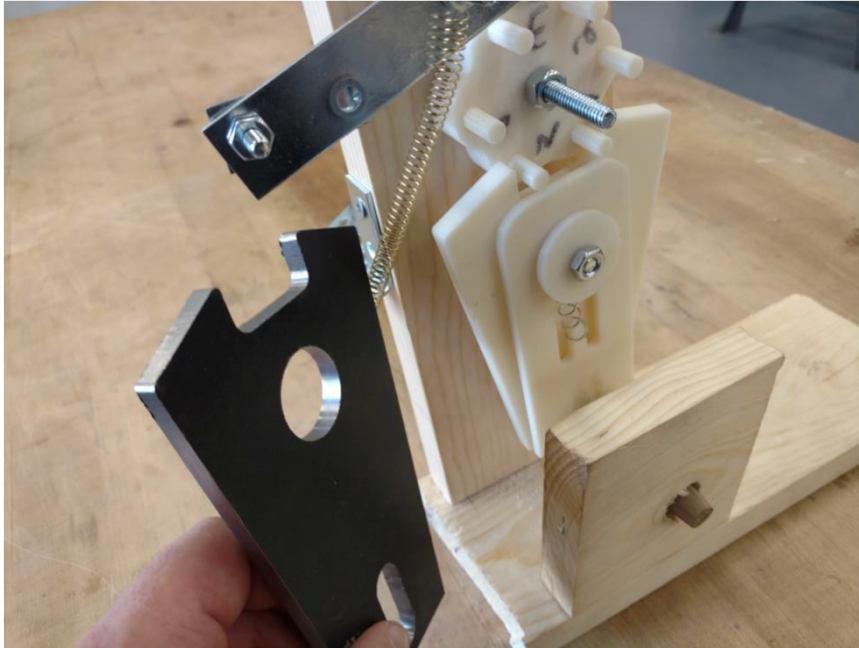

Figure 17: Shifter Rapid Prototype

The sequential shifter is in the final stages of production, with each individual component being machined and prepped for final assembly on the frame and transmission (Figure 18).



Figure 18: Machined Component for Shifter

9.3.2 Shifter

The shifter design is in the Solidworks phase of its design (Figure 19). Depending on the needed forces to rotate the shift shaft, the final dimensions will be altered for the best ratio of degrees of throw to leverage needed to shift each gear.

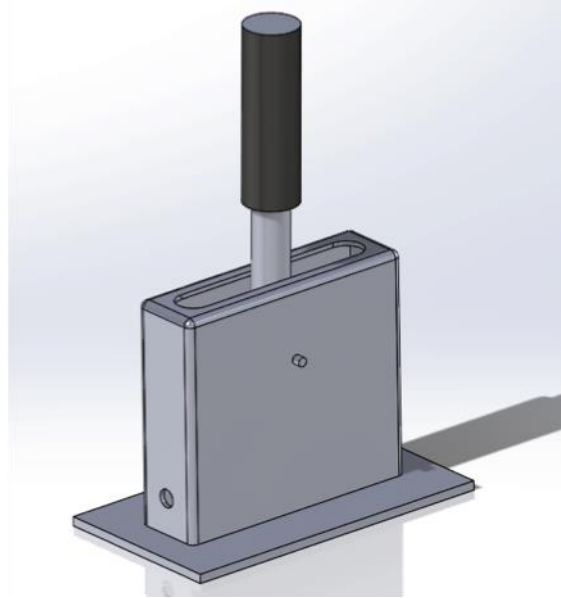

Figure 19: CAD for Shifter

10. Frame Analysis

Our frame design was modified and analyzed based on the design from 2014-2015 Baja group. There are two modification that we made. The first modification was made based on 2016 Baja SAE Rules. The rules says that “a bend that terminates at a named point implies the point lies between the tangents of the bend” [6], as shown in figure 20. The second modification was made because the FEA analysis of roll over of modification 1 fails.

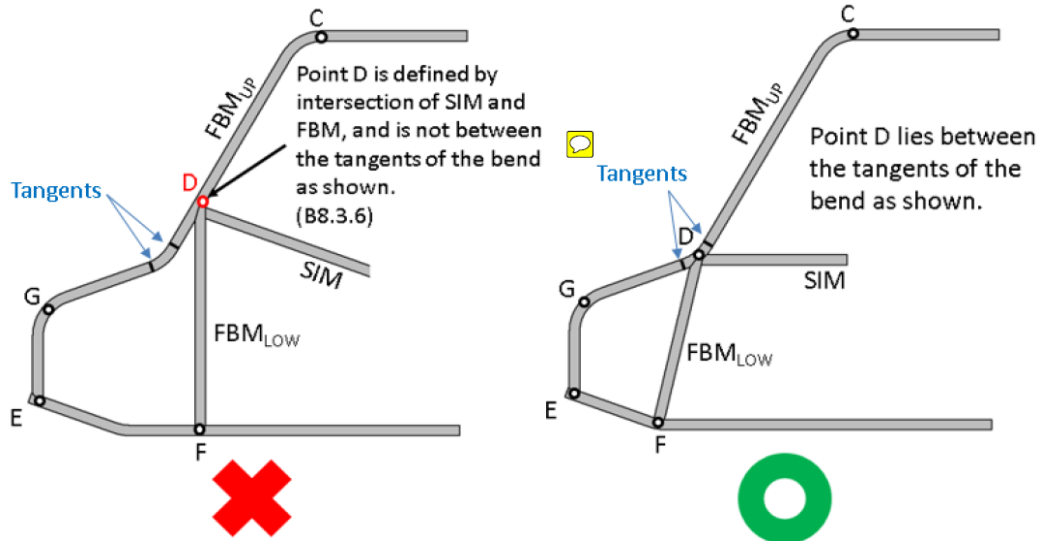

Figure 20: Frame Rules [6]

10.1 Modification 1

According to the SAE Baja Competition rules. The members have to be connected directly to the curve which is more than 30 degrees. As you can see in figure 21 (left), the curve of the frame at the front of the Baja has a degree more than 30 degrees, but another member is connected to the point below the curve. This is against the rule, and we do the modification as shown in figure 21 (right). The member is moved upwards and connected to the curve after the modification.

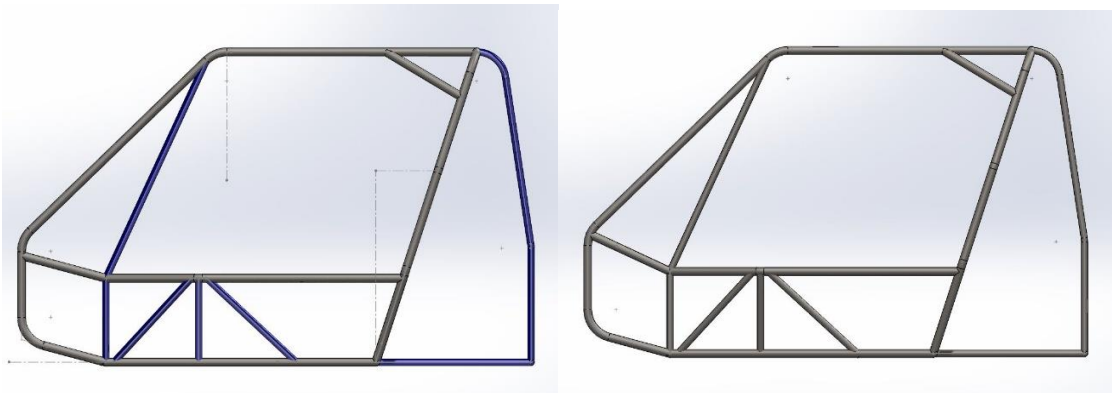

Figure 21: Old Frame CAD (left) Modification 1 Frame (right)

10.2 FEA Analysis for Modification 1

For this part, we assume that the all impact time is 0.2 second and the mass is 600 pounds (including the driver). We also assume the maximum velocity of the Baja is 25 mph. By the law of momentum, $mv=Ft$, we calculated the force acting on the Baja is 3419 pound-force. The first

analysis is for front-impact-test (Figure 22), and the minimum factor of safety is 3.04. The second analysis is for side-impact-test (Figure 23), and the minimum factor of safety is 2.22. The third analysis is for rear-impact-test (Figure 24), and the minimum factor of safety is 1.95. The last analysis is for roll-over-test (Figure 25), and the minimum factor of safety is only 0.774, which is a failure.

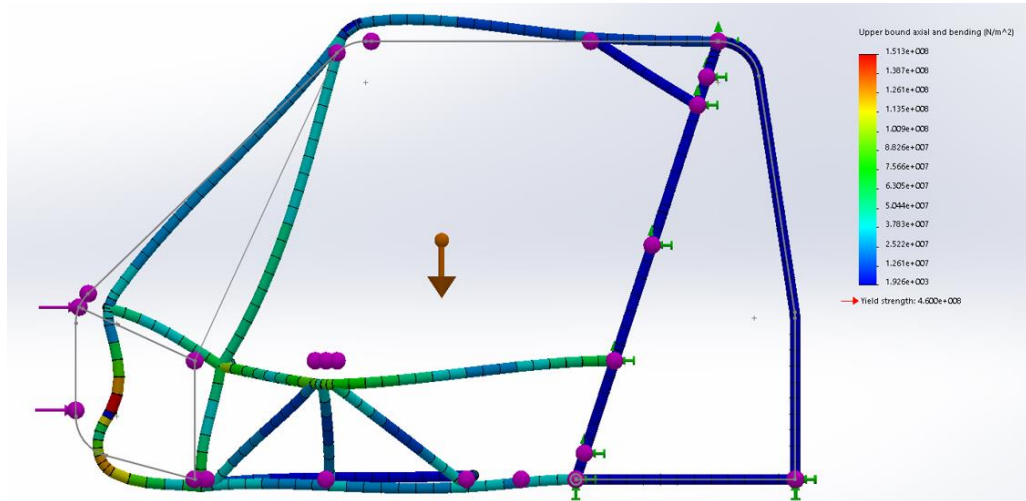

Figure 22: FEA Front Impact Result for Modification 1

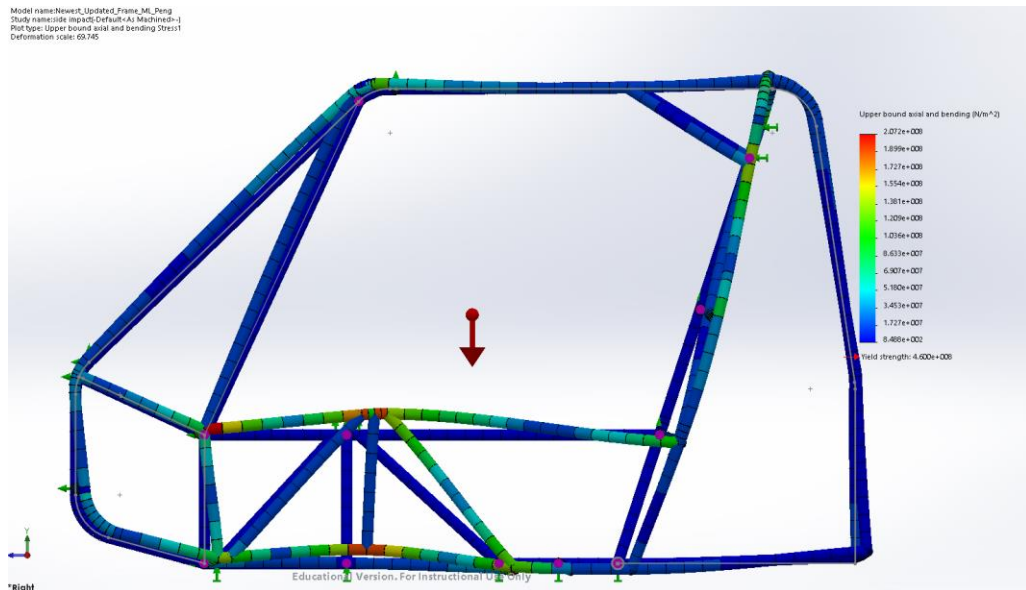

Figure 23: FEA Side Impact Result for Modification 1

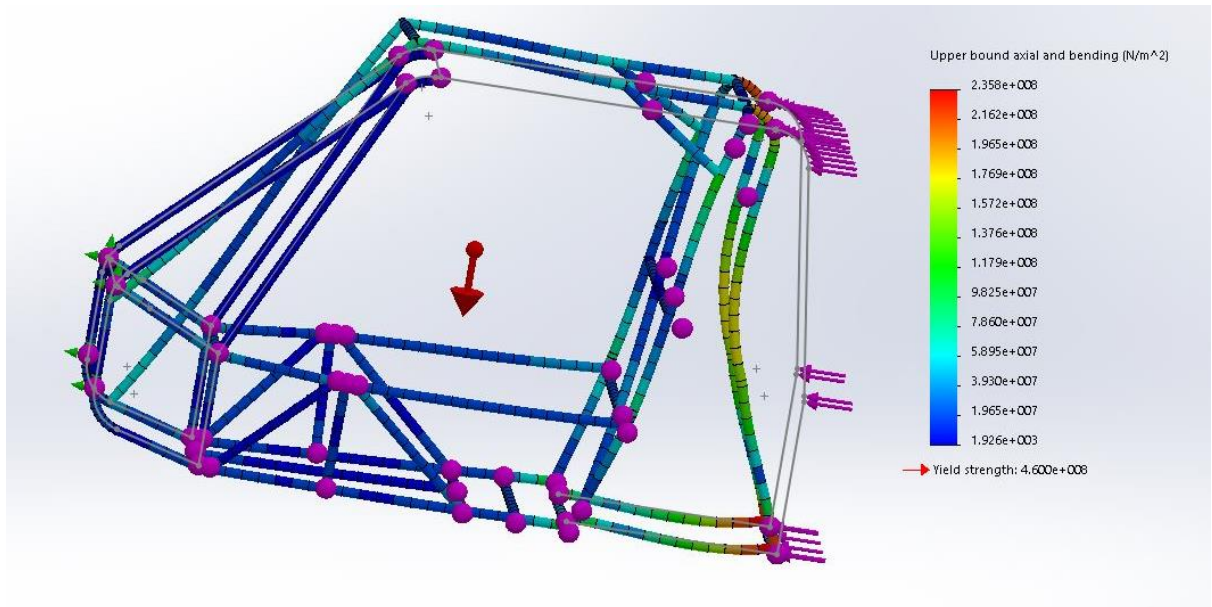

Figure 24: FEA Rear Impact Result for Modification 1

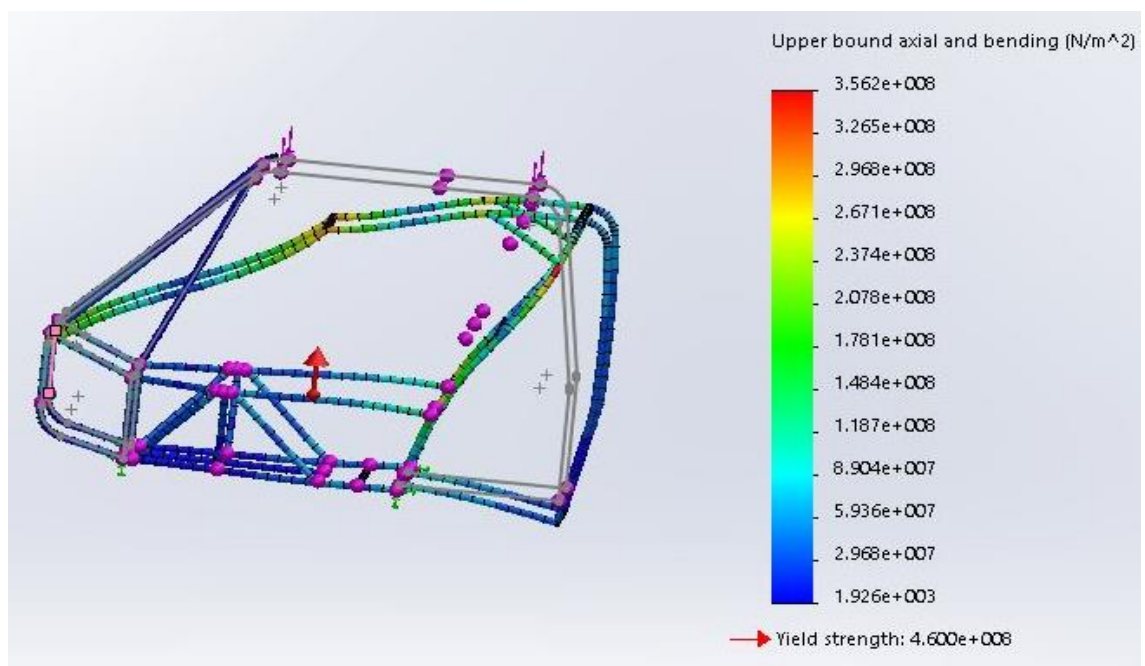

Figure 25: FEA Roll Over Result for Modification 1

10.3 Modification 2

Because the frame fails in the roll-over test, we decide to do another modification. From the FEA diagram generated from the roll-over-test. The maximum stress is at the top of the frame. We decide to add another member to support the frame (Figure 26).

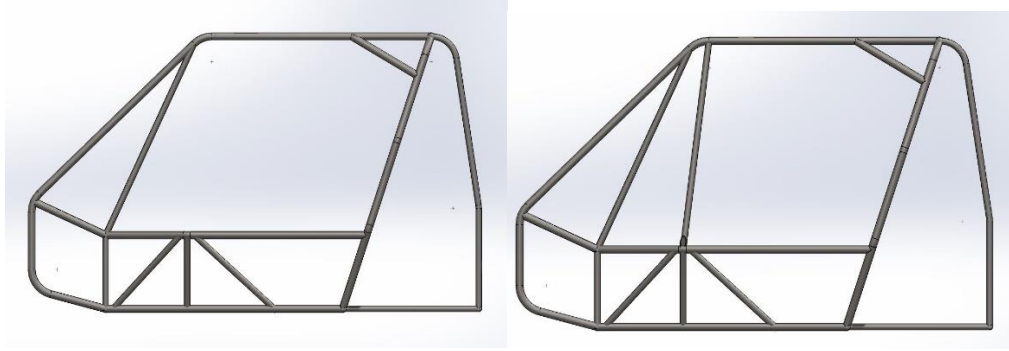

Figure 26: Modification 1 Frame (left) Modification 2 Frame (right)

10.4 FEA Analysis for Modification 2

After adding this member, another FEA is required to check if the modification works. We use exactly the same boundary condition for the tests and fix the same points. The first analysis is for front-impact-test, and the minimum factor of safety is 2.84. The second analysis is for side-impact-test, and the minimum factor of safety is 2.35. The third analysis is for rear-impact-test, and the minimum factor of safety is 1.99. The last analysis is for roll-over-test, and the minimum factor of safety is 2.62 (Figure 27-30).

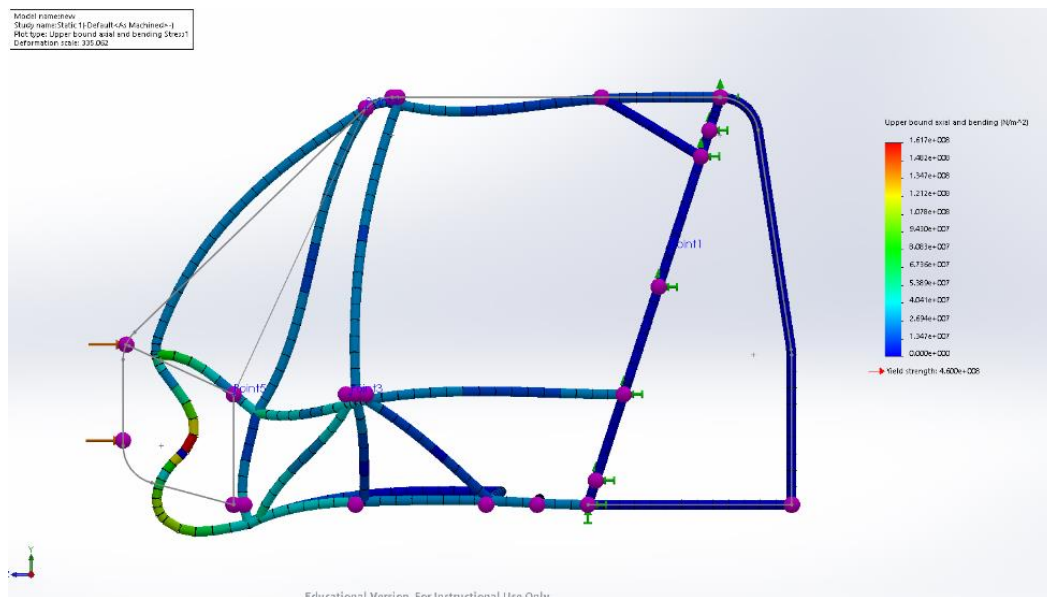

Figure 27: FEA Front Impact Result for Modification 2

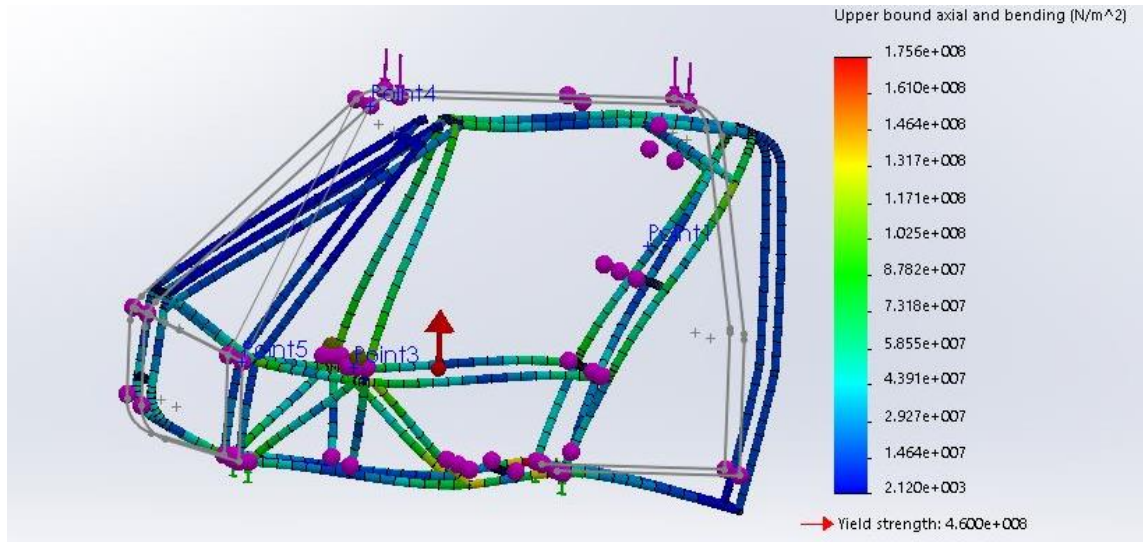

Figure 30: FEA Roll Over Impact Result for Modification 2

11. Designs in Progress

- Muffler location is our problem, Baja 2016 rules not allow to muffler comes out of frame from three directions of frame (right, back, left).
- Should be a muffler extension be in the straight direction or down, not in any other direction.
- Solving of our muffler problem, to make the muffler in 90 degree horizontal line, instead what we have now (55 degree).
- Dr. Tester request to re design throttle.
- Need to do new design for fuel catchment envelope of the vehicle envelope.

11.1 Muffler Design

11.2 Throttle Design

11.3 Fuel Catchment

12. Bill of Materials

The team came up with the bill of material table with just the raw material needed, not including the labor fee and material given. Firstly, for the frame analysis, we need to cut off three primary members and add two secondary members which cost approximately \$121.16. Secondly, for the

suspension, several razor half shafts for our three-link rear suspension cost \$539.98. Then for the transmission, we need a centrifugal clutch which is about \$500 and two 1018 steel forks which are about \$80. Moreover, we also need linkages and bearings for our shifting mechanism and steel pipe for the muffler. Lastly, gas pedal and gas will also be on the list. The cost in the table below (Table 1) is a roughly estimation of the material cost since current design may be changed further.

Table 14: Bill of Materials

Part Name	Sub-part/Material	Cost
Frame	AISI 4130 steel	\$121.16
Suspension	Razor Half Shafts	\$539.98
Transmission	Centrifugal Clutch	\$500
	1018 Steel Forks	\$80
Shifting	Linkage	\$60
	Bearing/metal	\$45
Muffler	Steel Pipe	\$7
Gas Pedal		\$15
Gas		\$15
Total		\$1383.14

13. Updated Project Plan

The table below is our updated project plan. As shown in the Gantt chart. We have been going through 15 weeks and the majority of design tasks are done. From the 16th week, we are going to finish all the individual work, such as welding, order the component and assembly, which will take almost 5 weeks. After that, we need to design the throttle and fuel catchment, which will take about 2 weeks. From week 22 and week 25, we are going to put everything together and finish this Baja. The task of the last two weeks, week 26 and week 27, is to test our Baja.

Table 15: Updated Gantt Chart

Task	1	2	3	4	5	6	7	8	9	10	11	12	13	14	15	16	17	18	19	20	21	22	23	24	25	26	27
Communicate With Client	█	█	█																								
Project Definitions	█	█	█	█	█	█	█	█	█	█	█	█	█	█													
Preparing Quality Function Deployment:	█	█	█	█	█	█	█	█	█	█	█	█	█	█													
State Of the Art Research	█	█	█	█	█	█	█	█	█	█	█	█	█	█													
Verify The Date of Frame	█	█	█	█	█	█	█	█	█	█	█	█	█	█													
Creating Function Diagrame:	█	█	█	█	█	█	█	█	█	█	█	█	█	█													
Conceptualizing Alternative Approach:	█	█	█	█	█	█	█	█	█	█	█	█	█	█													
Register with SAE	█	█	█	█	█	█	█	█	█	█	█	█	█	█													
Engineering Analysis for Current Baja	█	█	█	█	█	█	█	█	█	█	█	█	█	█													
Decision Matrices	█	█	█	█	█	█	█	█	█	█	█	█	█	█													
Brainstorming for the transmission	█	█	█	█	█	█	█	█	█	█	█	█	█	█													
Concept Selection:	█	█	█	█	█	█	█	█	█	█	█	█	█	█													
Budget Analysis	█	█	█	█	█	█	█	█	█	█	█	█	█	█													
Engineering Analysis for Improved Baja	█	█	█	█	█	█	█	█	█	█	█	█	█	█													
Fabracting Concept Protopyte:	█	█	█	█	█	█	█	█	█	█	█	█	█	█													
Order The Engine and Other Necessary Materials	█	█	█	█	█	█	█	█	█	█	█	█	█	█													
Testing Concept Protopyte:	█	█	█	█	█	█	█	█	█	█	█	█	█	█													
Developing Propoal Designs															█	█	█	█	█	█	█	█	█	█	█	█	█
Individual Design Work															█	█	█	█	█	█	█	█	█	█	█	█	█
Design Throttle and Fuel Catchment																						█	█	█	█	█	█
Build Main Baja Components																											█
Build Minor Baja Components																											█
Problem Definition and Project Planing				♦																							
Concept Generation and Selection								♦																			
Concept Protopyte														♦													
Project Proposal															♦												
End Break Continue Construction																											
Test Baja Final Construction																											♦

References

- [1] J. Tester, 'SAE Presence', EGR Building, 69, 2015.
- [2] Sae.org, 'SAE Mission and Vision Statements', 2015. [Online]. Available: <http://www.sae.org/about/board/vision.htm>. [Accessed: 25- Sep- 2015].
- [3] Erickson, Wallace D. *Belt Selection and Application for Engineers*. New York: M. Dekker, 1987.
- [4] Naunheimer, Harald. *Automotive Transmissions Fundamentals, Selection, Design and Application*. 2nd ed. Berlin: Springer, 2011.
- [5] Panchal, D. *Two and three wheeler technology*. New Delhi: Asoke K. Ghosh. 2015.
- [6] 2015. [Online]. Available: https://www.bajasae.net/content/2016_BAJA_Rules_Final-9.8.15.pdf. [Accessed: 11- Dec- 2015].