

SAE Mini Baja: Suspension and Steering

Midpoint Review

Zane Cross, Kyle Egan, Nick Garry, Trevor Hochhaus



March 12, 2015



Overview

- Final Suspension Design
- Rear Suspension FEA
- Front Suspension FEA
- Final Steering Design
- Tie Rod Design
- Future Tasks

Updated Final Designs

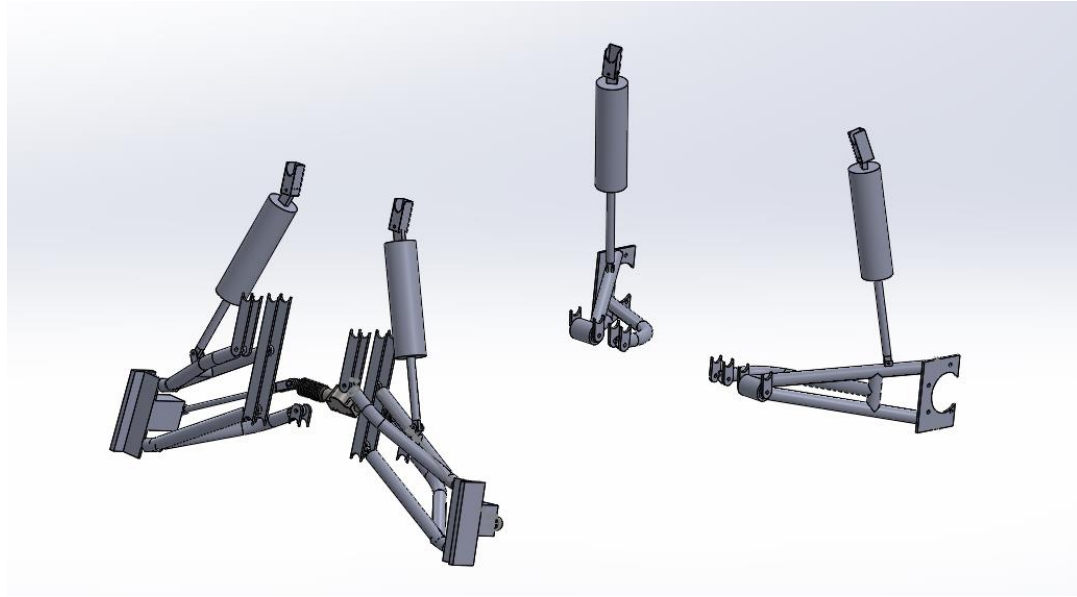
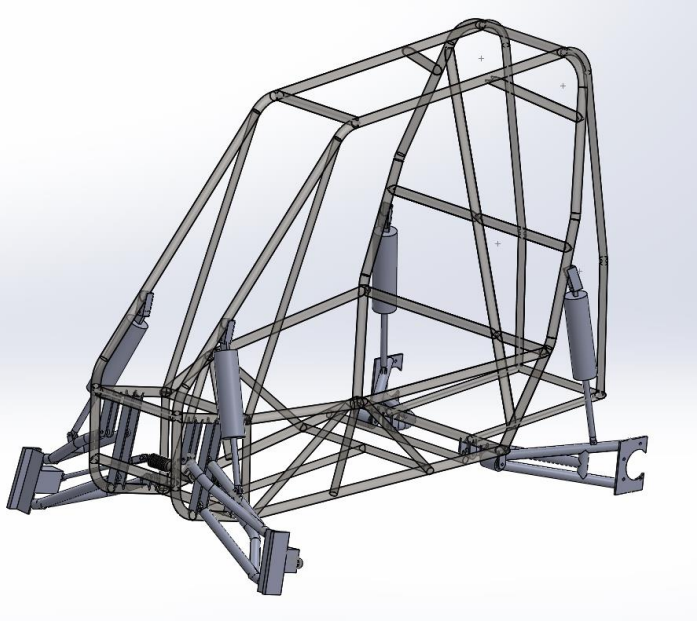

Rear 1-Link

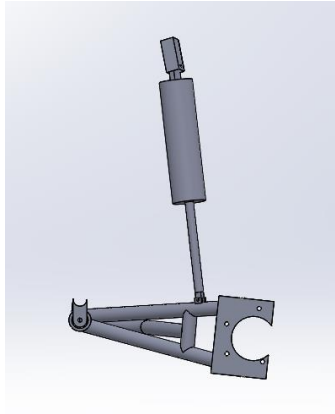

Side View

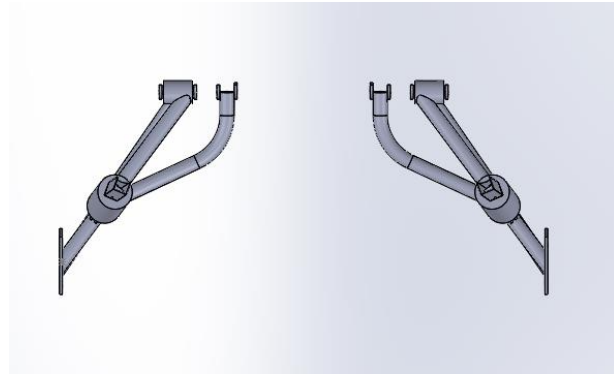

Top View



Rear Impact

Simulates a collision with another car at 5mph. The FOS for this simulation was 746.

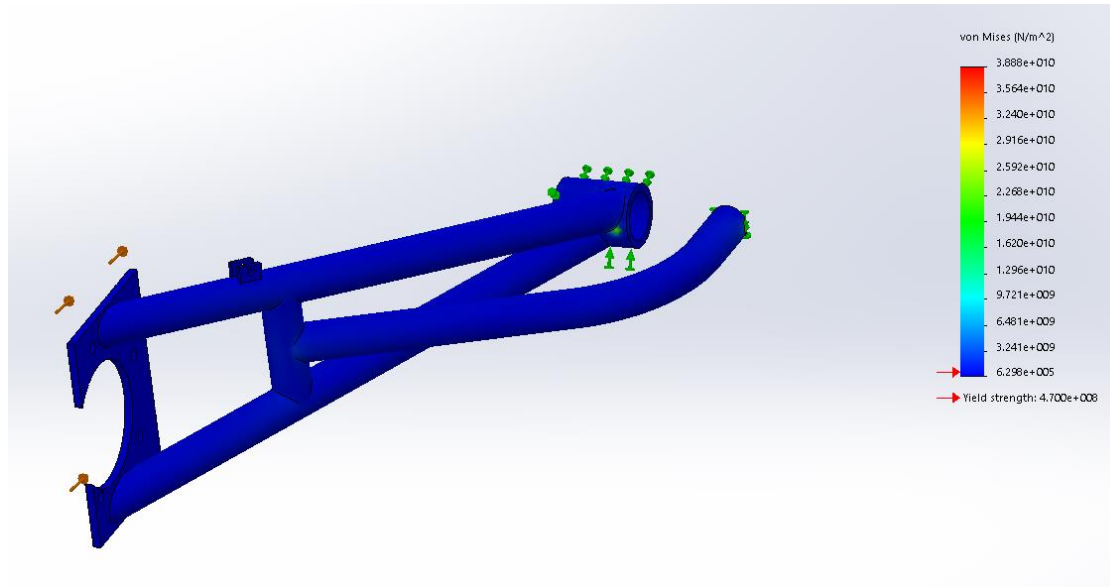

Vertical Loading

Simulates a 5 foot fall on one member. The factor of safety for this loading is 2.4

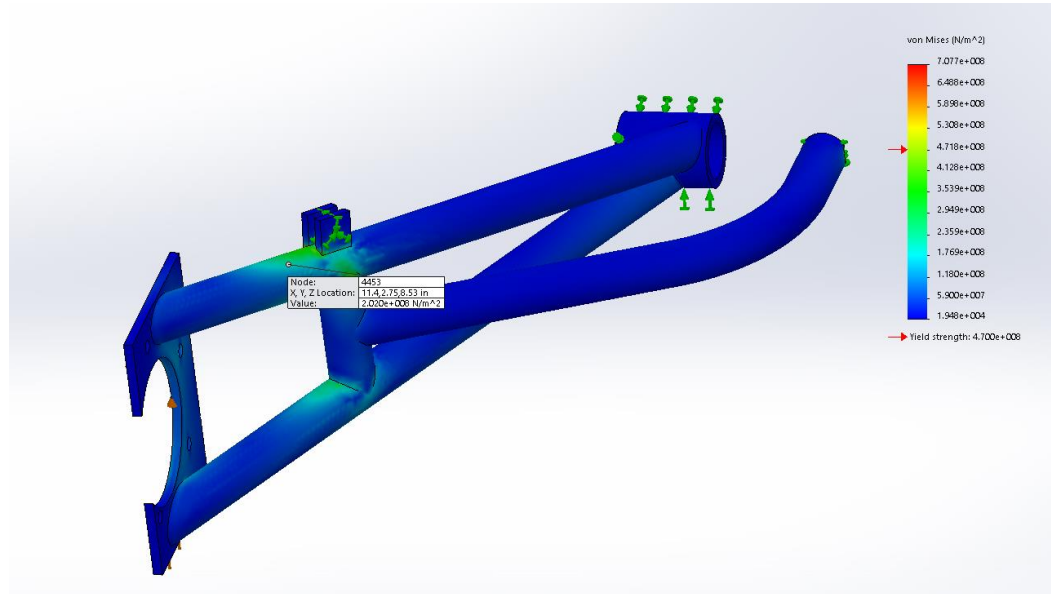

Side Impact

Simulates a collision at 5mph on one arm. FOS of 3.4 for this simulation.

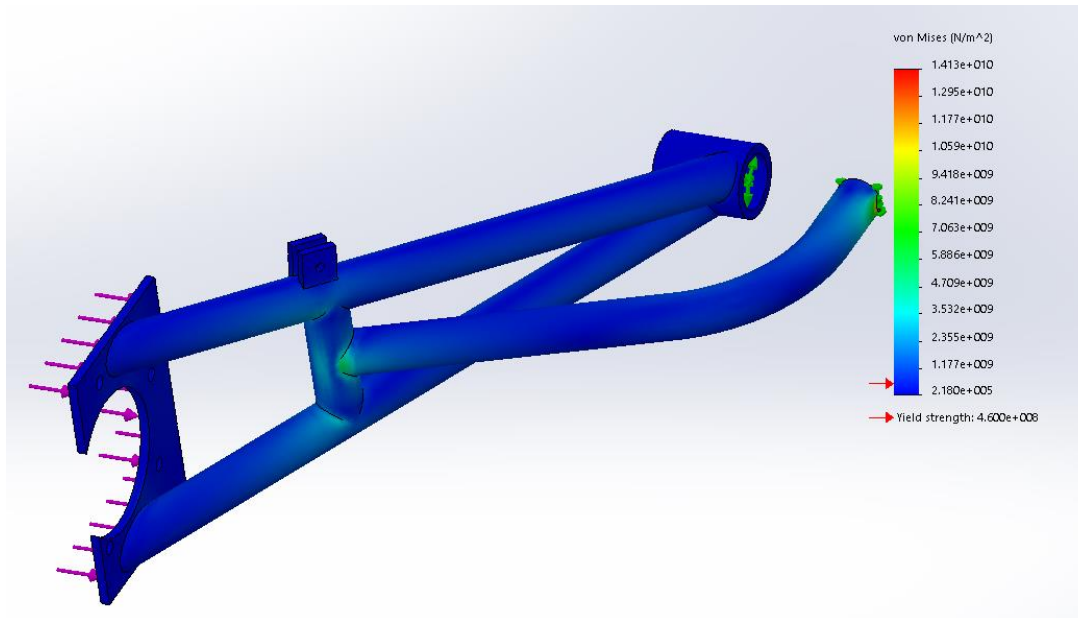

Front Suspension and Steering

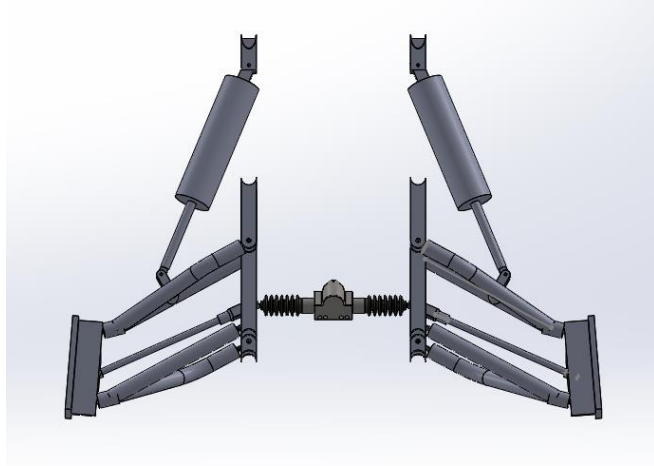

Front View

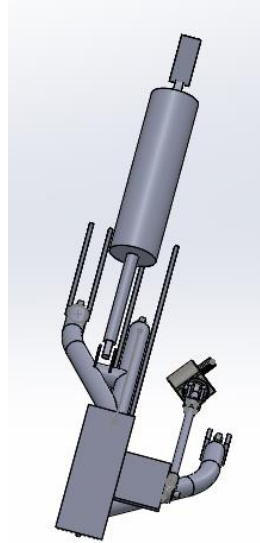

Side View



Lower A-Arm



Front Impact

Front Impact at 10 mph. FOS is 2.9.

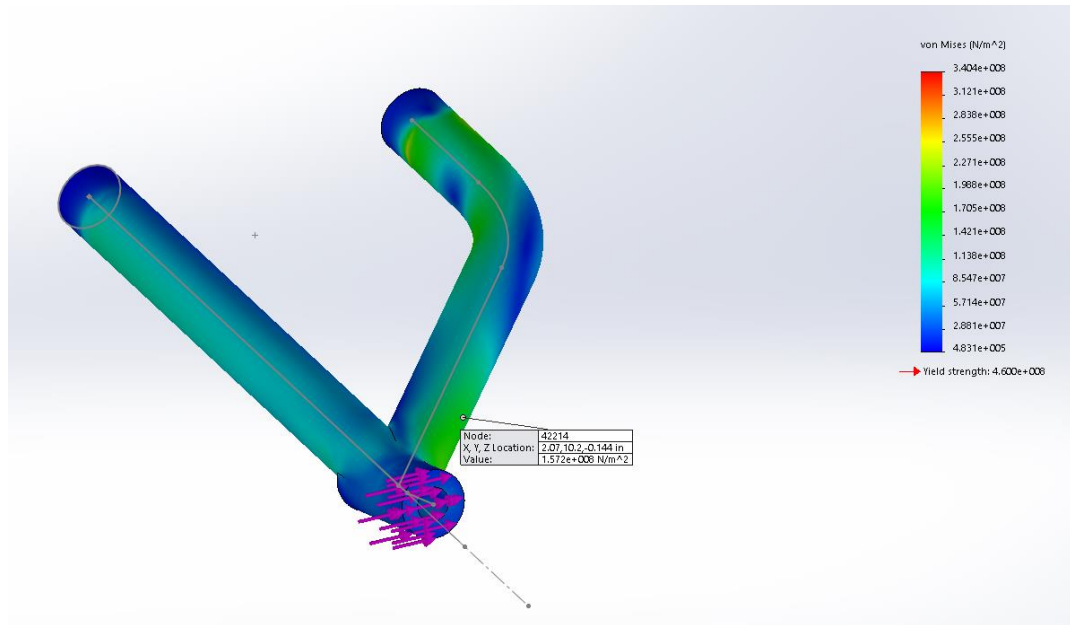

Nick Garry

Vertical Loading

Simulates a 5 foot drop on one corner. FOS of 2.8.

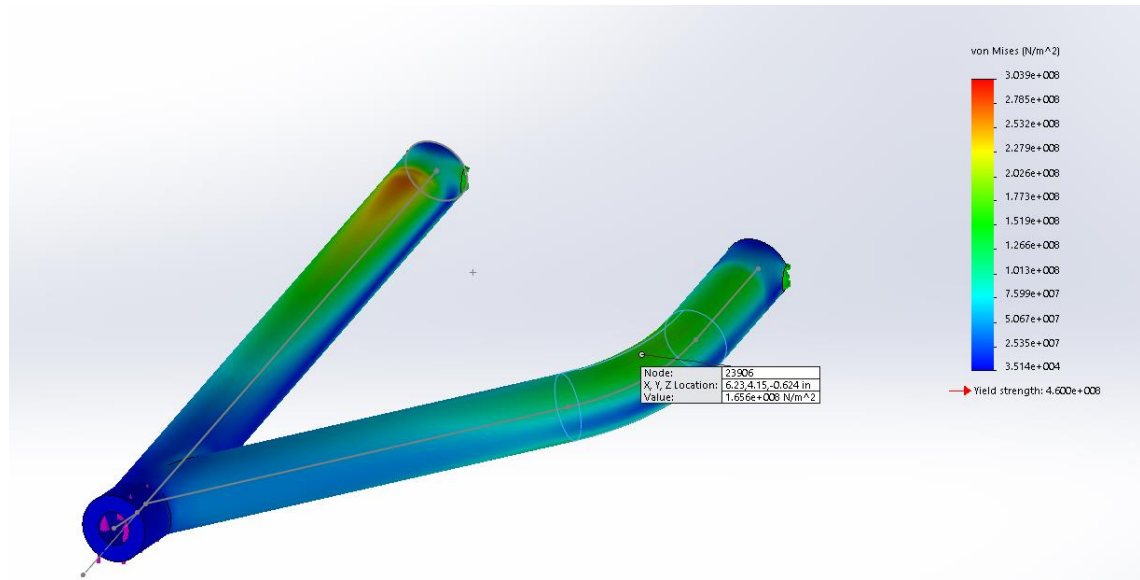

Side Impact

Simulates a side impact at 10 mph. FOS of 2.0.

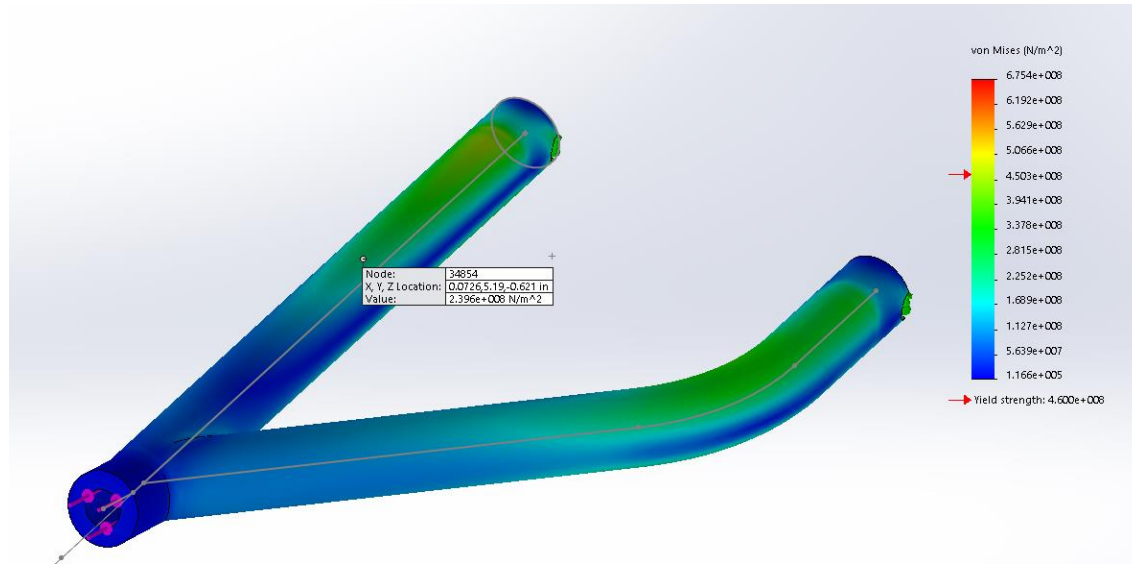

Upper A-Arm



Front Impact

Front Impact at 10 mph. FOS is 1.8.

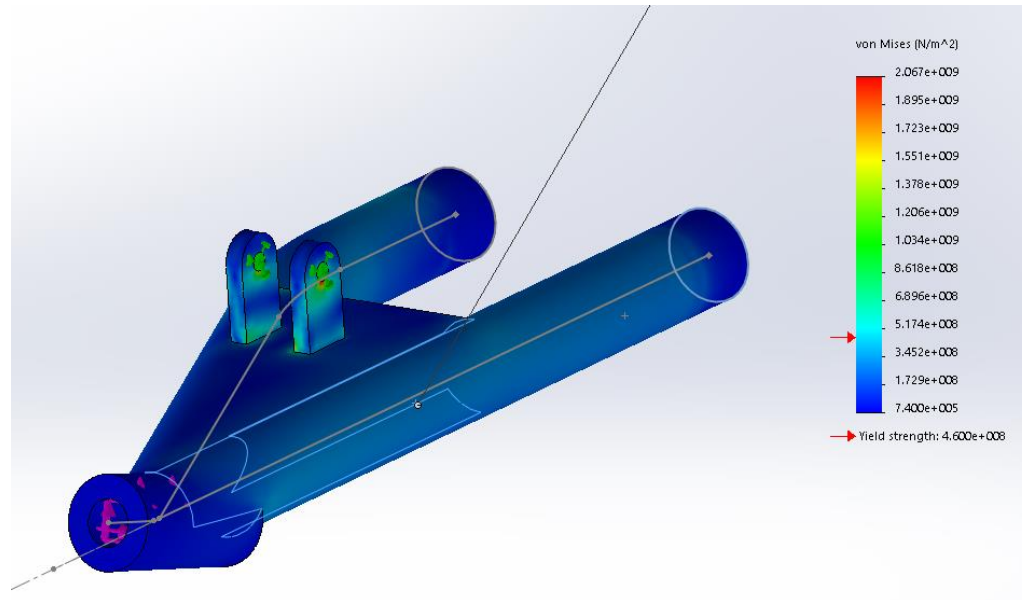

Vertical Loading

Simulates a 5 foot drop on one corner. FOS of 8.

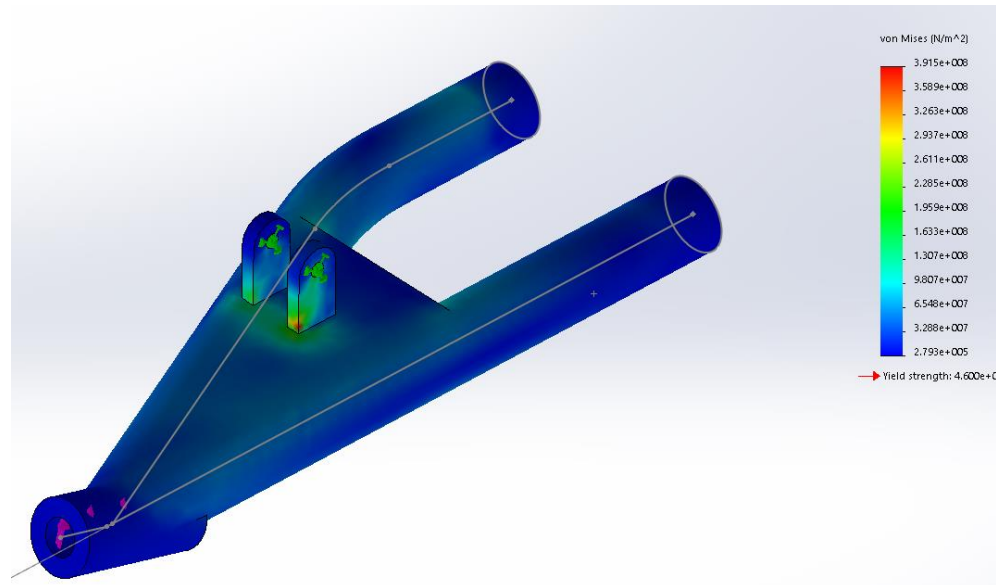

Side Impact

Simulates a side impact at 10 mph. FOS of 2.9.

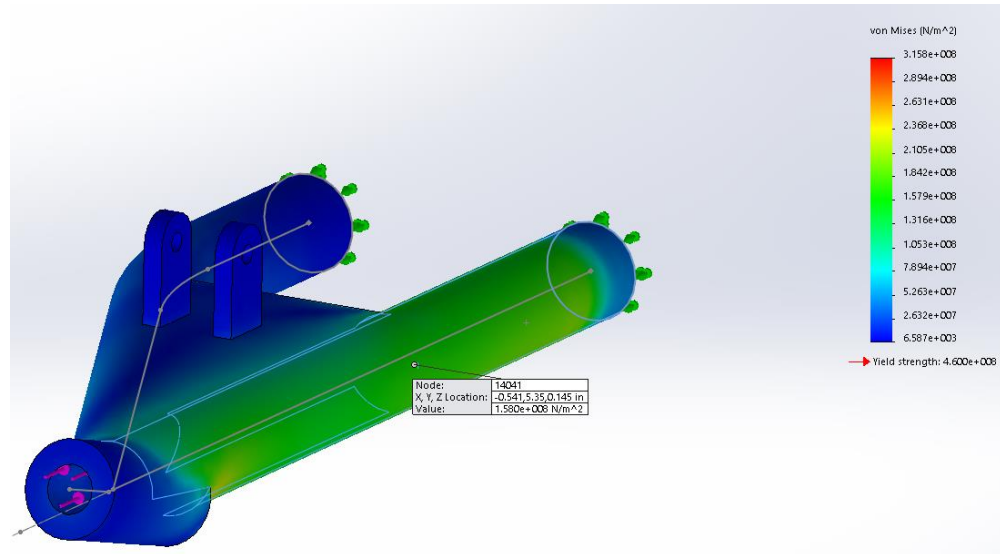

Steering Progress/Changes

New Track Width and Wheelbase

- Track Width = 53in
- Wheelbase = 75in

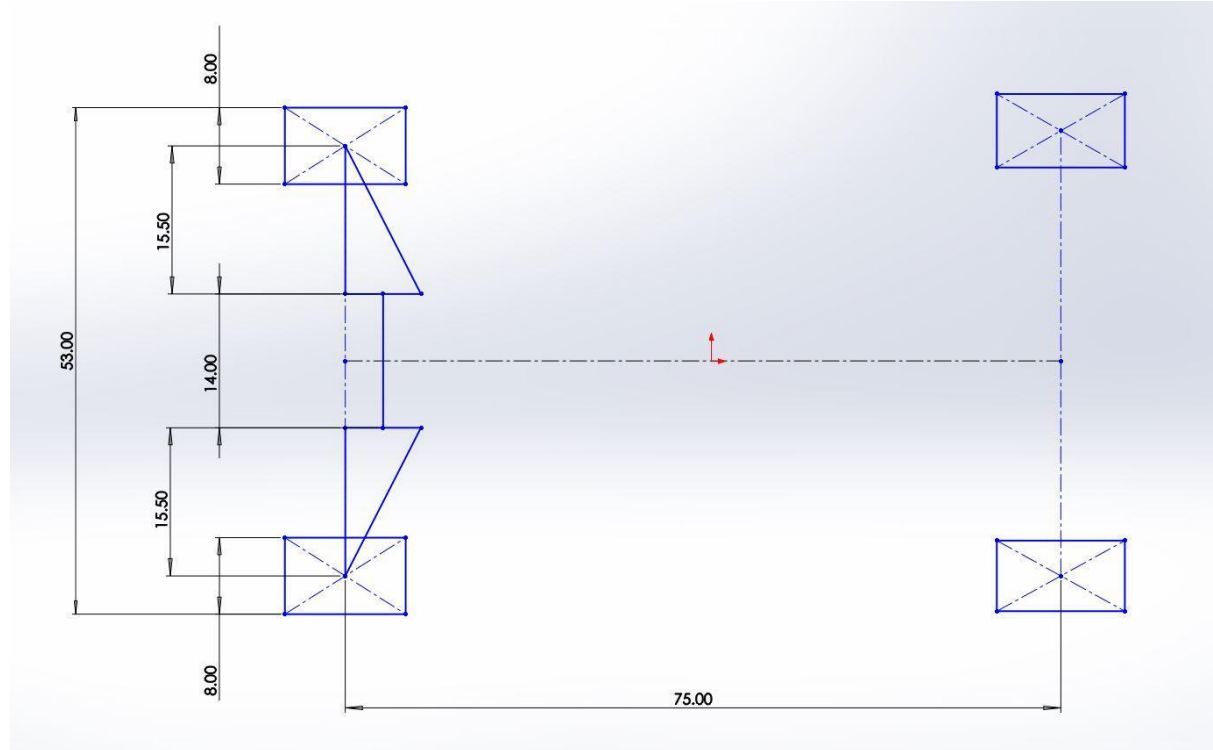

New Steering Angles

- Inside Tire Max Angle

$$\tan(\delta_i) = \frac{L}{R_1 - \frac{W}{2}}$$

- O

ngle

- II
- C

$$\tan(\delta_o) = \frac{L}{R_1 - \frac{W}{2}}$$

deg
8 deg

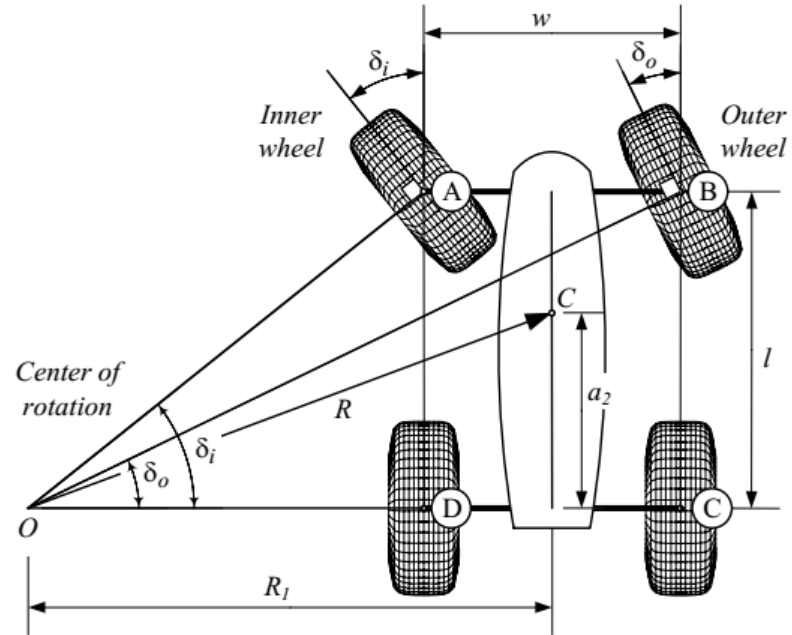

Final Steering Dimensions

- Rack Location = 2.08 in
- Tie Rod Length = 13.75 in
- Max Rack Travel = 2.45 in
- New Tie Rod Hub Mount (Y) = 4.32 in
- New Tie Rod Hub Mount (X) = 1.93in

- Vehicle Going Straight

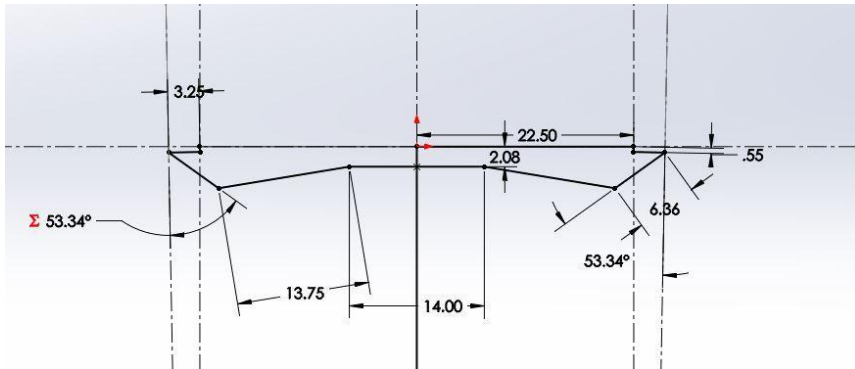

- Vehicle at Max Turning

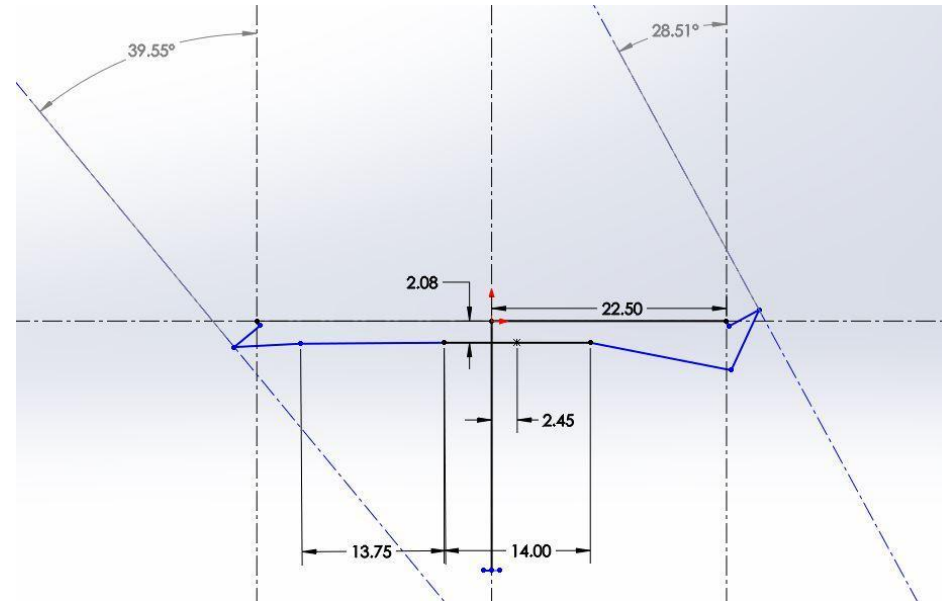

Manufacturing of Tie Rods



Updates Summary

Steering

- Re-defined wheelbase and track width
- Calculated steering angles
- Determined hub mount location
- Determined rack and pinion location
- Manufactured Tie Rods

Suspension

- Changed front shock position, A-arm width, and orientation
- Finalized and started manufacturing rear 1-Link

Future Tasks

- Fabricate Rack Mount
- Order Female Heim Joints
- Manufacture New Tie Rod Hub Mount
- Order plate/tab material
- Manufacture mounting plates and tabs
- Final assembly and testing