

SAE Mini Baja 2014-2015

By

Ahmed Alnattar, Neil Gehr, and Matthew Legg
Team 11

Final Report

Document

April 22, 2015

*Submitted towards partial fulfillment of the requirements for
Mechanical Engineering Design II – Spring 2015*



Department of Mechanical Engineering
Northern Arizona University
Flagstaff, AZ 86001

Table of Contents

| | |
|---------------------------------------|-----------|
| Introduction..... | 3 |
| Problem Statement..... | 3 |
| Customer Needs | 4 |
| Goals..... | 4 |
| Constraints..... | 4 |
| Objectives..... | 5 |
| QFD | 5 |
| Concept Generation | 6 |
| Truck Frame Design | 6 |
| Old Volkswagen Design..... | 6 |
| Front Bracing Design..... | 7 |
| Rear Bracing Design | 8 |
| Front Supported Design | 9 |
| Compact Concept Design | 10 |
| Matrix and Criteria | 10 |
| Frame Designs | 11 |
| Front Supported Design | 11 |
| Front Brace Design | 12 |
| Testing and Calculations | 13 |
| Simulation Results | 18 |
| Final Frame Design..... | 20 |
| Frame Fabrication | 22 |
| Finished Frame..... | 26 |
| Cost Analysis | 29 |
| Conclusion | 31 |
| References | 32 |

Introduction

Society of Automotive Engineers (SAE) is a world known association for setting standards in the automotive industry around the world. SAE is also interested in collegiate opportunities and participates to help educate and stimulate future engineers. For many years SAE has helped students of all ages to develop skills and increase knowledge in mechanical operations and properties. For Northern Arizona University (NAU), the senior capstone mechanical engineering students are participating in competitions held by SAE in the fields of the regular class aero, the micro aero, and the mini baja vehicle.

The mini Baja project is a compilation of design, from the ground up, of suspension, steering, drivetrain, frame, wheels, and overall presentation with respect to cost. The vehicle needs to be built to handle off road conditions and be competitive in different dynamic events against other schools' teams. The events at the competition that the Baja vehicle will have to go through are acceleration, hill climb/traction event, maneuverability, endurance, and the sales presentation event. Each event is worth a certain amount of points, adding up to a total of 750 allowable points. Based on how the vehicle does in each event, the team will be ranked accordingly out of 100 positions. The closer you are to being ranked number 1, the better your vehicle is overall. This 2014-2015 competitions rules and locations have been released by SAE, as every year there are changes made to requirements and locations.

This report provides an overview of how the frame team decided to design the frame, stress analyses on the frame, how the frame was manufactured, material used, and cost analysis.

Problem Statement

Here at NAU, Dr. John Tester has assigned the senior design project of the SAE Mini Baja to a set of ten senior mechanical engineering students. The task is to design and build the SAE mini Baja for the 2015 SAE competitions that will outperform Dr. John Tester's SAE mini Baja of 2014.

For the capstone project of the mini Baja, the frame team has been made up of three of the ten students working on the capstone project. The frame team is focusing on the design and building of a single seat mini Baja frame that a fictitious firm would want to manufacture. The frame will be put through a series of dynamic events that will test the structural integrity.

Customer Needs

Dr. Tester's highest concern with the previous Baja vehicle was the weight. Last year's mini Baja vehicle weighed about 650 lbs in total [1]. This caused them to have an acceleration struggle as well as a lower top speed while competing with the other mini Baja vehicles that had better power to weight ratios. Dr. Tester also needs the front of the frame to have a front angle for clearing obstacles and climbing hills [2].

Goals

The frame team of the mini Baja vehicle has many goals. One goal is to design and build a light weight frame that will meet strength, safety, and dimension requirements for SAE Baja competition(s) and our customer needs. Another goal is to integrate all additional equipment into the frame with mounting tabs. Last year's mini Baja team did not design the frame with the thought or consideration of how the suspension and other components of the vehicle were going to be installed, and thus had to increase the number of structural members along with the weight of the vehicle. This year, the frame team is going to make sure to consider all other components of the vehicle when designing the frame. A third goal for us is to try and incorporate packaged extras that the vehicle can have installed while not being used in the competitions such as a glove box in the front of the vehicle, a speaker system, a winch, and additional body paneling for cosmetics. These extras will attract a buyer's eye, while not affecting the ability of the Baja while it is being used for competitions. The driver ergonomic design is another goal for the frame team because comfortability is important. The driver should be able to drive the vehicle with ease while not getting fatigued or cramped from driving the vehicle in competition. While keeping all of these goals in mind, we realize that the frame needs to be as inexpensive as possible to manufacture, but good enough to outperform the previous NAU Mini Baja teams in the competitions with our current constraints.

Constraints

Most of the constraints that we must adhere to are within the 2015 SAE Mini Baja rules which can be found on their web page [9]. A few extra constraints that we are being given is that

the total width of the vehicle must not be wider than 59 inches and that the total weight must not be exceed 450 lbs.

Objectives

The objectives for the frame team are to:

- Design and build a light weight frame of a maximum of 150 pounds
- Design a frame that can be built within a short amount of time
- High enough strength to withstand a roll over and/or a collision
- Build the frame with considerations to all other components of the vehicle with respect to the overall dimensions so that it may be transported to and from competitions with ease

QFD

The following is the QFD with our engineering requirements and customer's needs along with the House of Quality that shows the positive or negative correlations. This chart also shows the NAU's and ASU's previous mini Baja strengths in correlation with Dr. Tester's requirements.

| Relationships | |
|---------------|---|
| Strong | ● |
| Moderate | ○ |
| Weak | ▽ |

| Engineering Requirements | Column # | 1 | 2 | 3 | 4 | 5 | Bench Marks | |
|--------------------------|----------|--------|----------|------------|--------|------------|--------------------|--------------------|
| | | Weight | Strength | Build Time | Cost | Dimensions | NAU Baja 2013-2014 | ASU Baja 2013-2014 |
| Overall Weight | | ● | ○ | | ▽ | | - | + |
| Dimensions | | ○ | | | ○ | ● | - | + |
| Weight Distribution | | ● | ○ | | ▽ | | + | + |
| Safety & Ergonomic | | | ● | | ○ | ○ | + | - |
| Units | | lbs | lb#N | Days | \$ | in. | | |
| | | 450 | 5,000 | 30 | 10,000 | 59 | | |

Figure 1 - QFD with HOQ: The above figure shows the relationships between customer requirements and the engineering requirements.

Concept Generation

The team came up with six different designs for the overall frame. Below are the descriptions of each design.

Truck Frame Design

One of the frame design concepts was a truck frame design. The concept behind this frame design was to build a vehicle as a truck with toe and chamber off road racing suspension. Since a lot of trucks are built to be driven on rough road and under rough conditions, a truck design can be a durable baja frame. The advantage to using this design is due to it being light weight and unique. In all the previous competitions, there has never been a frame design that had a bed, which would be appealing to a fictitious buyer. The disadvantage to this design would be that there is not much room for the other components such as the motor. A sketch and an image are included below, to better represent the idea of the Truck Frame Design, Figure 1.

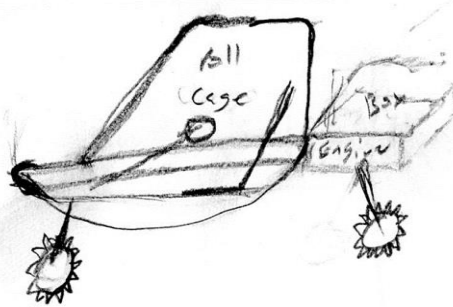

Figure 1: Truck Frame Design [9]

Old Volkswagen Design

The Old Volkswagen Buggy Design is a baja frame that is built like an old Volkswagen buggy vehicle with toe and chamber off road racing suspension. Since this is a common off road vehicle that is small, it would be appealing for this competition since the frame for these vehicles

perform well in off road environments. The advantages to this design is the size, which would decrease weight and cost along with a unique oval design. This design can also be equipped with a front trunk that is also appealing to a fictitious buyer. The disadvantage to this design would be the design would be hard to keep within SAE Baja 2015 Rules. A sketch and an image are included further, so the idea can be better seen and visualized, Figure 2.

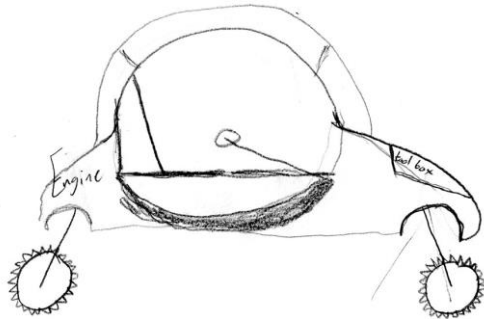

Figure 1: Old Volkswagen Design [10]

Front Bracing Design

The Front bracing concept incorporates the minimum amount of required members needed for front bracing according to the 2015 SAE Mini Baja Rules. This design also has a front approach angle integrated into the frame. Some advantages of this design are that this design allows for pure customization of the rear of the vehicle for suspension and drivetrain sub groups to install their designs with ease. It adds weight to the front of the vehicle which positively impacts the front to rear weight ratio. The main disadvantage of this design is that there is an added member in the front of the vehicle that can lower the vision of the driver. A right side view of the Front Bracing Design can be seen below in Figure 3.

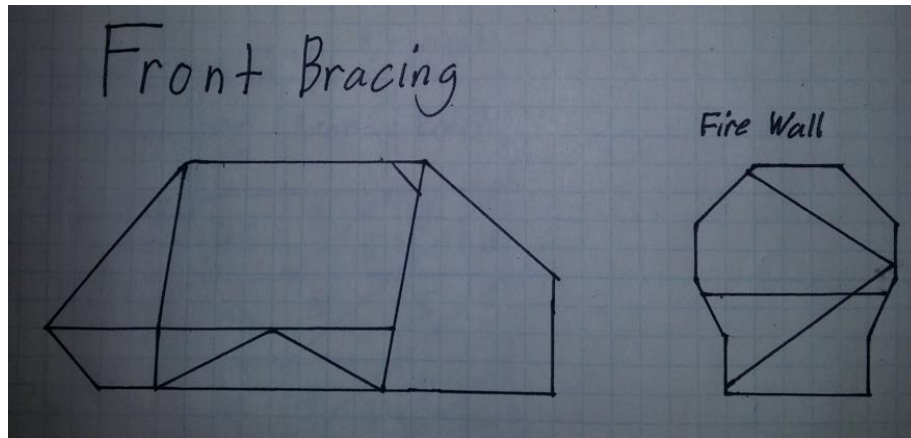

Figure 2: Front Bracing Design

Rear Bracing Design

Below is Figure 4, a right side view of the rear bracing design.

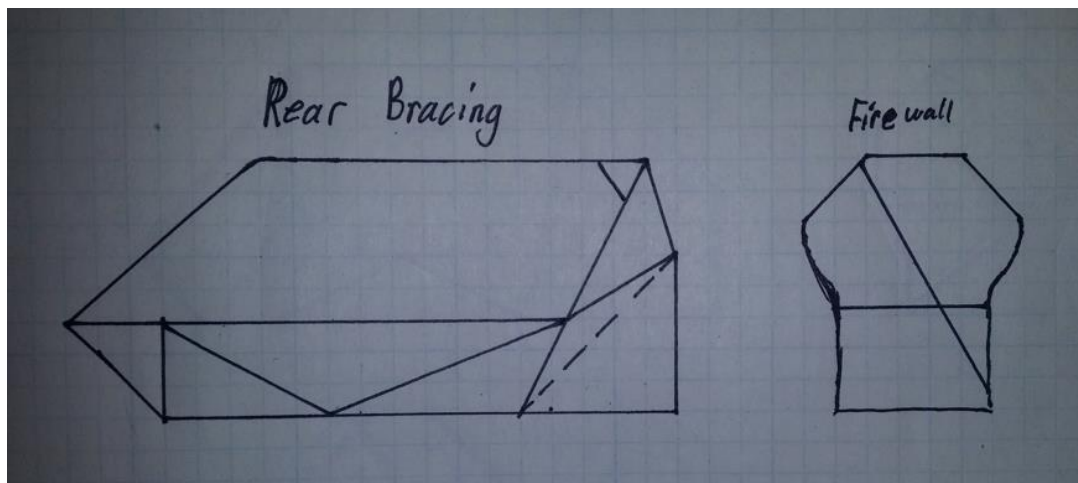

Figure 3: Rear Bracing Design

The rear bracing concept incorporates the minimum amount of members required by the rules established by the 2015 SAE Mini Baja Rules. Along with having the minimum amount of members required, the frame design also has a front that is angled for approaching hills and rocks. Some advantages to this design: It allows for a simpler firewall design because of the extra added support members that will be in the rear of the vehicle, behind the driver. The rear

bracing member can be moved depending on the needs of the suspension and drivetrain team as show below in Figure 5 with the blue dotted lines.

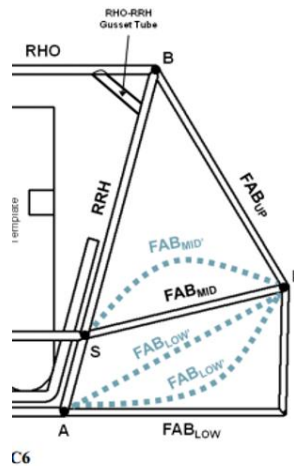

Figure 4: Rear Supporting Members [11]

The main disadvantage to the rear bracing design is that it negatively impacts the weight ratio of the vehicle with more weight being added to the rear of the vehicle.

Front Supported Design

Front Supported is a front supported frame design which conforms to the 2015 SAE Mini Baja Rules. The focus of this design was to decrease the length (Δy) of the frame as much as possible to keep the weight down. Also to decrease weight, this concept uses as few as members as possible. The advantages to using this design is that since there are few members, it would be simple to build. This would also decrease the cost of the frame along with the weight. The disadvantages to this design is that it would not be as strong as some of the other designs due to fewer number of members supporting the frame. Also since it is taller, it has a higher chance to flip due to a higher center of gravity. This design can be seen on the right in Figure 6.

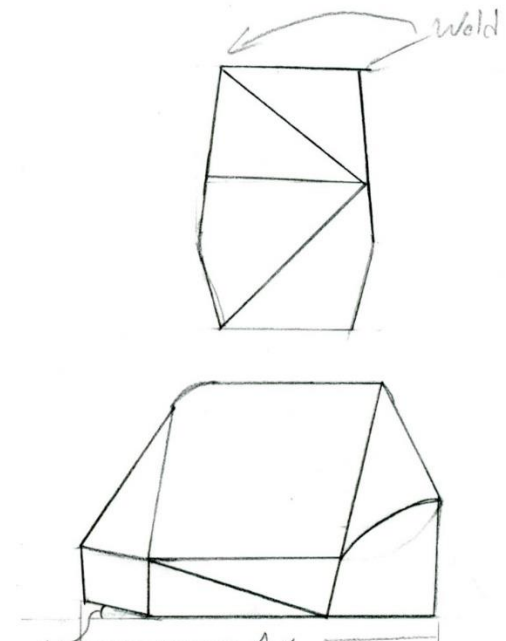

Figure 5: Compact Concept Design 1

Compact Concept Design

Compact Concept Design is a front supported frame design which conforms to the 2015 SAE Mini Baja Rules. The focus of this design was to decrease the width (Δx) and the height (Δz) as much as possible to keep the weight down. The advantages to using this design is that the weight distribution of the frame will be towards the front, helping the overall weight distribution. This frame is also short which allows for a lower center of gravity. The disadvantages to this design is that it is more complex to build, which takes more time to manufacture.

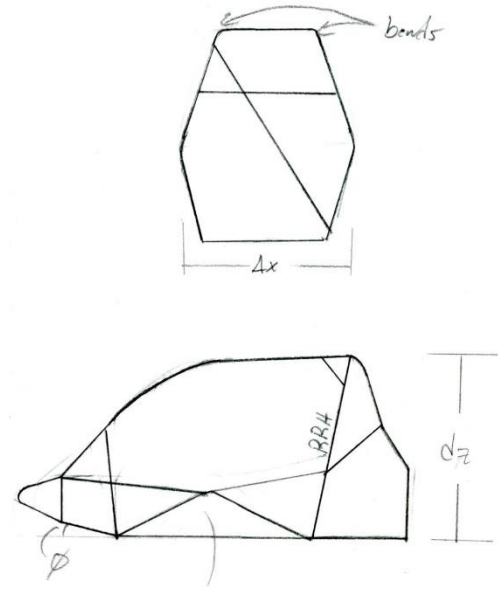

Figure 6: Compact Concept Design 2

Matrix and Criteria

To determine which designs would be used, the team made a decision matrix with the following criteria: Overall Weight, Cost, Strength, Room for Modifications, Simplicity, Ability to Install Accessories, and Driver Accessibility. Each criteria was weighted differently, with Overall Weight and Cost being highest weighted criteria and Ability to Install Accessories being the lowest weighted criteria. Each team member was then given a decision matrix to fill out on their own for the six designs. Table 1 below shows the final decision matrix, which is the average points of all the team member's decision matrices.

Table 1: Group Decision Matrix

| Criteria Rating System: 1 - 5 | | | | | | | | |
|-------------------------------|----------------|----------------------|----------|------------|------------------------|------|------------------------|-------------|
| Designs | Overall Weight | Driver Accessibility | Strength | Simplicity | Room for Modifications | Cost | Ability to Accessorize | Total Score |
| Truck Frame | 2.67 | 3.67 | 3.33 | 3.33 | 3.0 | 3.0 | 3.33 | 3.12 |
| Volkswagen Buggy Frame | 3.00 | 3.67 | 4.33 | 2.67 | 2.33 | 3.33 | 3.67 | 3.30 |
| Rear Brace | 4.67 | 4.33 | 4.00 | 3.67 | 4.00 | 4.33 | 3.67 | 4.17 |
| Front Brace | 4.67 | 4.33 | 4.33 | 3.67 | 4.33 | 4.00 | 3.67 | 4.21 |
| Front Supported | 4.67 | 4.33 | 4.00 | 4.33 | 4.00 | 4.33 | 3.67 | 4.23 |
| Compact Frame | 4.33 | 4.33 | 4.67 | 3.00 | 4.00 | 4.33 | 3.67 | 4.15 |
| Scale | 20% | 9% | 18% | 10% | 14% | 20% | 9% | |

As shown in the Group Decision Matrix, Table 1, the two top designs were the Front Brace design and the Front Supported design. Out of the six designs, Front Brace Design and the Front Supported design won due to how light weight they are. Dr. John Tester explained that his greatest need for the new frame is for it to be light in weight. With these two designs having the highest final scores, they were chosen from the decision matrix. These two designs will now be used to design a single frame that will be presented to Dr. Tester for approval along with stress analysis on the frame. Once the team receives approval from Dr. Tester, the team will then start to build a prototype frame for testing and more analysis.

Frame Designs

Below, are the descriptions of the two frames, Front Supported and Front Brace, in more depth along with figures for visual representation.

Front Supported Design

The Front Supported frame was designed to be compact and light in weight. It is made designed with 1 inch diameter 1018 steel with a wall thickness of 0.12 inches which is the smallest piping allowed in competition. The 2014 Baja frame has a width of 36 inches and length of 90 inches, while the Front Supported frame has a width of 44 inches and a length of 76 inches.

Along with smaller dimensions, its mass is only 158 pounds. The Front Supported frame can be seen below in Figure 8.

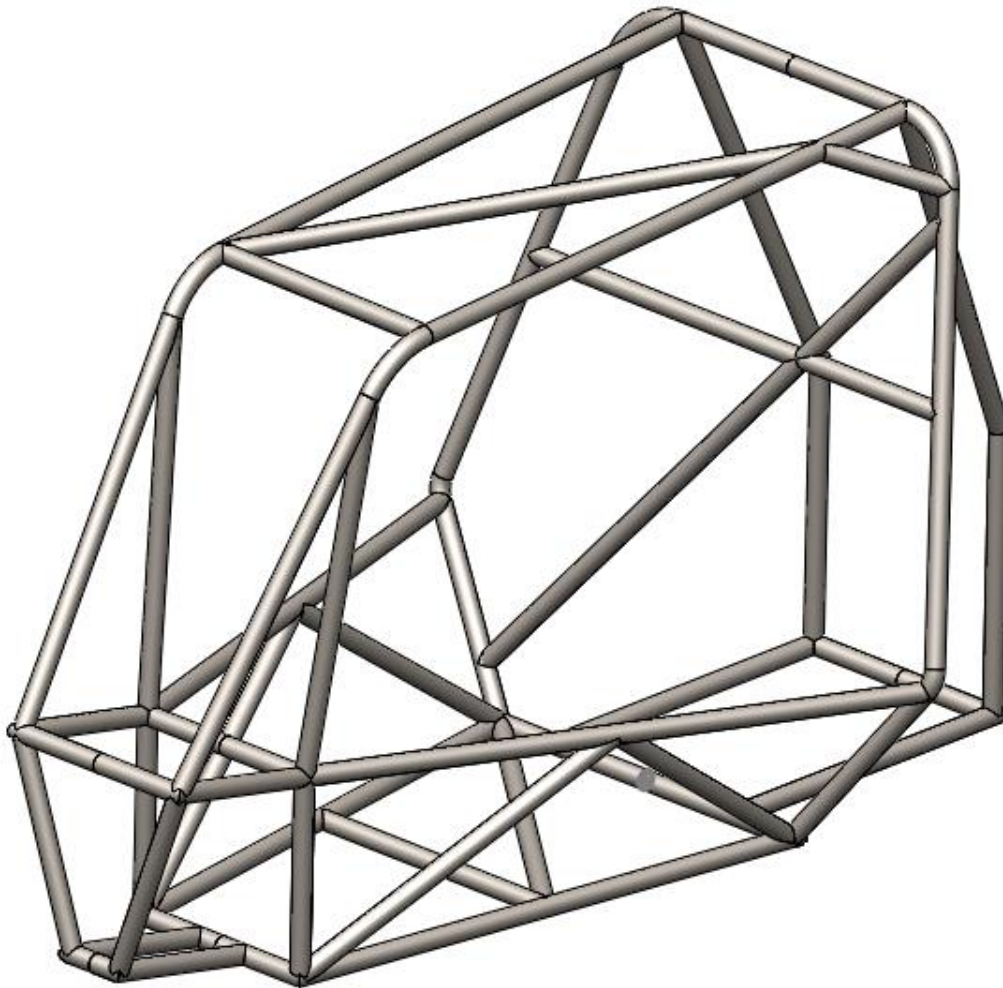

Figure 8: Front Supported Frame Design

Front Brace Design

The front brace design frame includes the minimum amount of members required by the rules from SAE. The purpose of having as few members as possible is to make the frame as light as it can be while still performing well under dynamic forces. It is a better choice over a rear bracing design as it helps distribute the weight from the rear of the vehicle to the front. This frame is going to be built with 1018 steel tubing for the primary and secondary members. Both the primary and secondary members will have an outer diameter of 1 inch and a wall thickness of

0.76 and 0.93 inches respectively. This frame design has an approximate weight of 154 pounds with a width of 29.75 inches and a length of 76 inches. The design still allows for the driver to be safe from harm in case of a crash, and does not over cramp the driver of the vehicle. The frame can be seen below in Figure 9

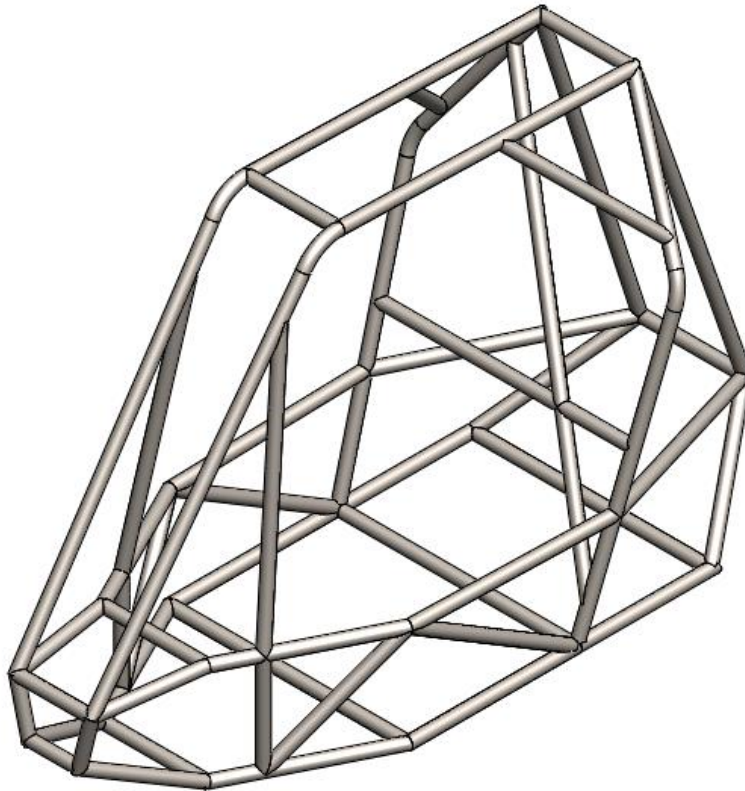

Figure 9: Front Bracing Frame Design

Testing and Calculations

For the two final designs of the frame, our frame team used SolidWorks Simulation to test the stresses, the displacement, and the overall factors of safety for the designs upon impact. The frame team completed a Finite Element Analysis (FEA) test on each frame to determine the weakest areas on the frames. This analysis allows the team to make any necessary changes before building the actual frame. The frame analysis was based on applying four different

simulation studies on the two frames, and each simulation study describes different scenario of collisions. The scenarios tested were drop test, front impact, rear impact, and side impact. Below in Figure 10 shows the drop test scenario.

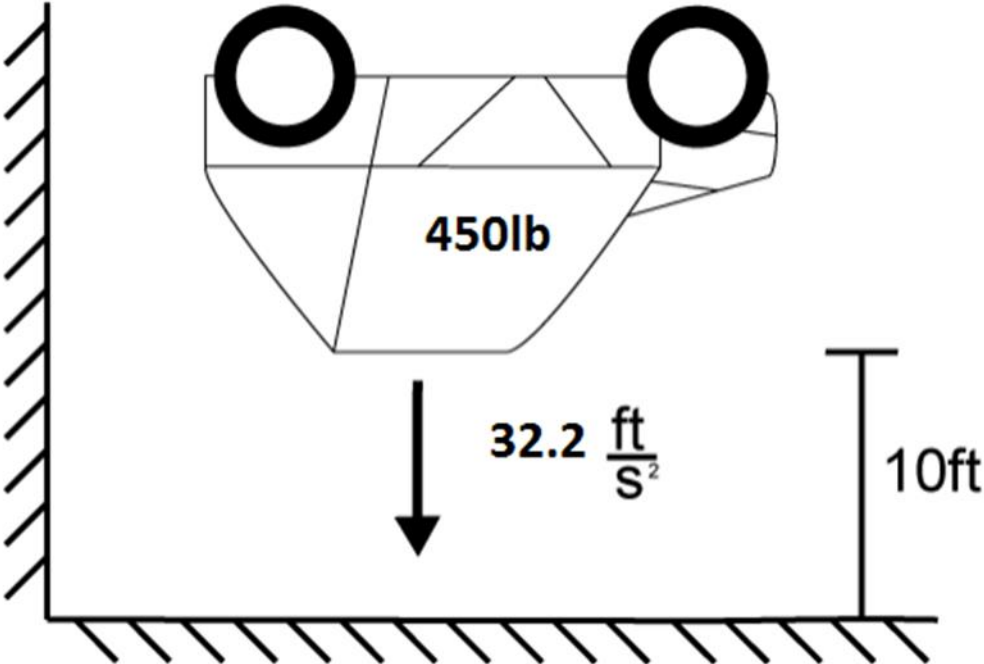

Image 10: Drop Test Scenario

For the frame drop test, it was assumed that the vehicle rolled over and landed upside down from a height of 10 feet. In addition, the weight of the vehicle is 450 pounds and the impact time is 0.1 seconds. In order to analyze the frame in a rollover scenario, the following equation needed to be used to determine the force of impact.

$$F = m \cdot \frac{\sqrt{2gh}}{t} \tag{1}$$

Where,

$F = total\ force\ (lbf)$

$m = object\ mass\ (lbm)$

$g = \text{acceleration of gravity } (ft/s^2)$

$h = \text{drop height } (ft)$

$t = \text{impulse drop test time } (s)$

In order to run the drop test simulation study and receive better test results, the team had to define the applied force on the chosen beams. This force is the total force, equation (1), divided by the total length of members the force is applied to. This force is illustrated as,

$$F_a = \frac{F}{l} \quad (2)$$

Where,

$F_a = \text{applied force } \left(\frac{lbf}{in}\right)$

$F = \text{total force } (lbf)$

$l = \text{total length of members force is applied to } (in)$

For the remaining impact test scenarios to be conducted on the frame in the SolidWorks Simulation studies, a different method to calculate the total force is needed. The total force used to analyze the front, rear, and side impact tests is different than what is used in the drop test. This method was applied to all the remaining three simulation studies. Our front, rear, and side impact simulation studies were tested based on assuming a vehicle weight of 450 pounds, an initial impact velocity of 25 miles per hour (mph), and an impulse impact test time of 0.2 seconds. In order to analyze the frame experiencing front, rear, and side impacts, a mathematical calculation is needed to calculate the total force. From the total force the team can then determine the applied force to be used for testing the various impact scenarios. As a result, the following equation is obtained.

$$F = m \cdot \frac{V_0}{t} \quad (3)$$

Where,

$F = \text{total force } (lbf)$

$m = \text{object mass } (lbm)$

$V_0 = \text{initial impact velocity (ft/s)}$

$t = \text{impulse impact test time (s)}$.

In order to run the different impact tests and receive accurate test results, the team had to define the applied force on the chosen beams. This force is basically the total force, equation (3), divided by the total length of members the force is applied to. Thus, this force can be illustrated as,

$$F_a = \frac{F}{l} \quad (4)$$

Where,

$F_a = \text{applied force (}\frac{\text{lb}}{\text{in}}\text{)},$

$F = \text{total force (lb)},$

$l = \text{total length of members force is applied to(in)}$.

In Figure 11, the front impact scenario is shown as if the 450 pound baja vehicle would collide at an impact velocity of 25 mph into a wall. The applied force distribution is applied on the front members of the vehicle, while the rear-end members of the vehicle are chosen to be fixed.

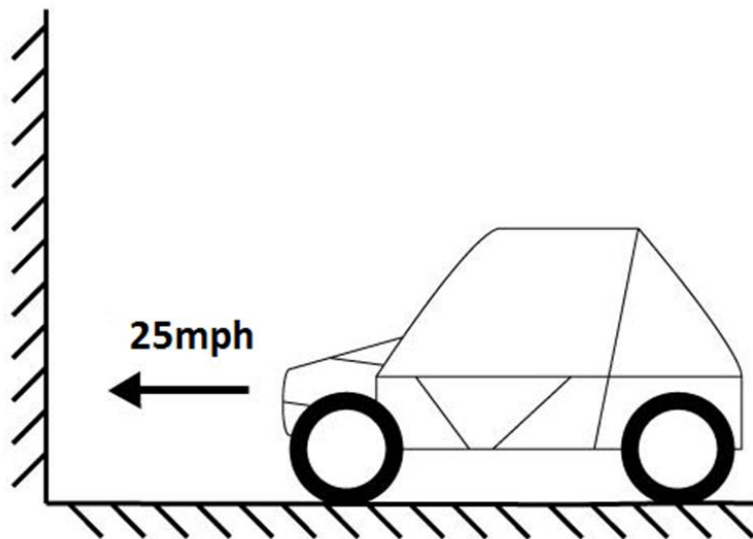

Figure 11: Front Impact Scenario

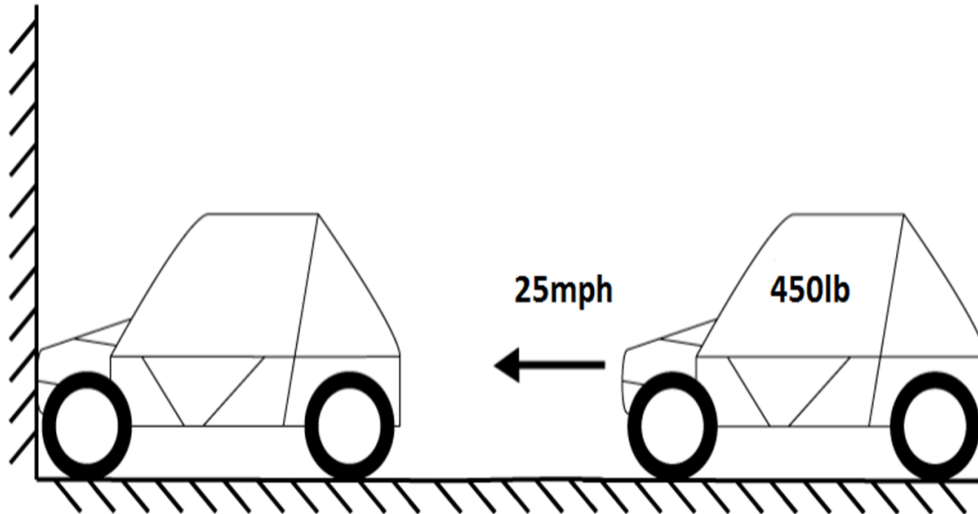

Figure 12: Rear Impact Scenario

Figure 12 illustrates the impact scenario of the baja vehicle being hit by 450 pound baja vehicle from the rear end. This scenario can be described as if an approaching vehicle collides with the baja vehicle from the rear at an initial impact velocity of 25 mph. The applied force distribution is applied at the rear end members of the vehicle, while the front of the baja vehicle is chosen to be fixed.

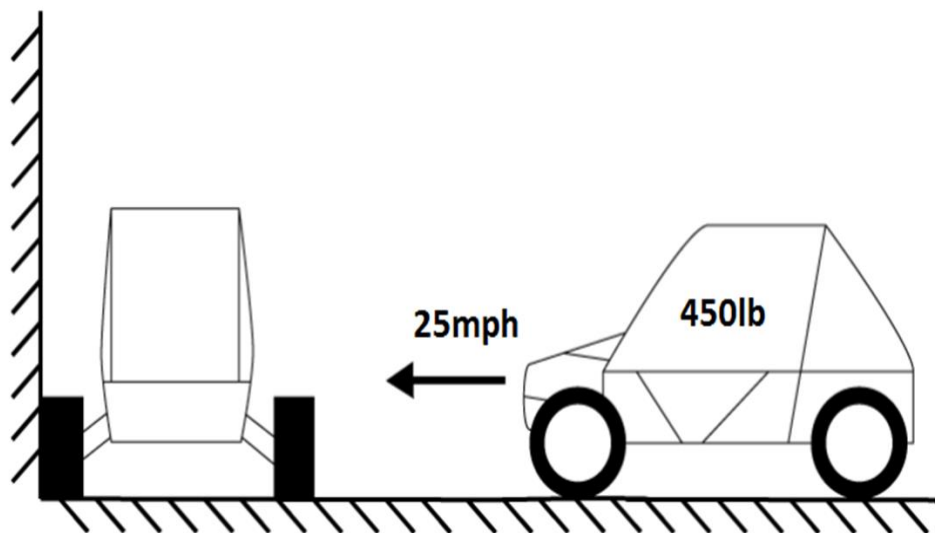

Figure 13: Side Impact Scenario

Figure 13 illustrates the impact scenario of the baja vehicle being hit by 450 pound baja vehicle from the side. This scenario can be described as if a vehicle collides with the baja from the side at an initial impact velocity of 25 mph. The applied force is to the members on one side of the vehicle in a plane, while the members on the other side of the vehicle are set to be fixed.

Simulation Results

The results generated for the two frames are discussed below. The factor of safety (FOS) of the frame has to do with the material being used and the configuration the members are in when a load is applied. Table 2 below shows the factors of safety for the two frames for each of the tests that were completed.

Table 2: Factor of Safeties from the Simulation

| Tests | Front Supported | Front Bracing |
|--------------|-----------------|---------------|
| Drop Test | 2.7 | 4.3 |
| Front Impact | 4.7 | 3.6 |
| Rear Impact | 4.0 | 3.5 |
| Side Impact | 2.0 | 6.5 |

As seen from the values obtained for the factors of safety, both vehicles exceed a required FOS value of two, but the Front Bracing design out performs the Front Supported design.

Deformation of members is also a major concern for the safety of the driver since crushing the driver is a possibility. In Table 3 below, the maximum deformation for the two frames can be seen for each of the tests that were completed.

Table 3: Maximum Deformation from the Simulation

| Tests | Front Supported | Front Bracing |
|--------------|-----------------|---------------|
| Drop Test | 0.265 | 0.103 |
| Front Impact | 0.28 | 0.34 |
| Rear Impact | 0.113 | 0.051 |
| Side Impact | 0.198 | 0.086 |

As seen from the values obtained for the deformation, both frames have an extremely small maximum value of deflection proving that both designs are capable of protecting and insuring the safety of the driver. The front bracing design is shown to deflect less overall.

The concentration of stresses that the frame members receive are important to know so that the failure points may be assessed in the most extreme scenarios. In Table 4 below, the maximum stress for the two frames can be seen for each of the tests that were completed.

Table 4: Maximum Stress from the Simulation

| Tests | Front Supported | Front Bracing |
|--------------|-----------------|---------------|
| Drop Test | 25.0 | 15.3 |
| Front Impact | 15.4 | 18.7 |
| Rear Impact | 16.7 | 19.2 |
| Side Impact | 33.5 | 10.5 |

As seen from Table 4, the Front Supported frame experiences higher amounts of stress than the Front Bracing frame. This would have to do to the frame having less supporting members in high stress areas. The Front Bracing frame out performs the Front Supported frame.

Based off the results, the team decided that the Front Bracing Frame was the frame that would be presented to the client and be further modified for suspension and drivetrain teams.

This decision was based on its better performance in the stress analysis scenarios than the Front Supported Frame.

Final Frame Design

After presenting the Front Bracing Frame to Dr. Tester, suspension, and drivetrain teams, they were all able to add feedback on how to incorporate all other parts into the frame. With their input, the frame was modified for a finalized design.

Modifications made to the frame was to have the correct spacing in the front for the suspension arms. When comparing the Front Bracing Frame to the Finalized Frame, the front becomes more of a box shape and the horizontal members are parallel to each other. This was need for the front suspension to install and work properly. Members have been added near the driver and in the rear for more stability as requested by Dr. Tester. Lastly, primary members will be 4130 chromoly steel tubing with a diameter of 1.25 inches and wall thickness of 0.065 inches, while secondary members will be 1 inch diameter and wall thickness of 0.035 inches. The Finalized frame is shown below in Figure 14.

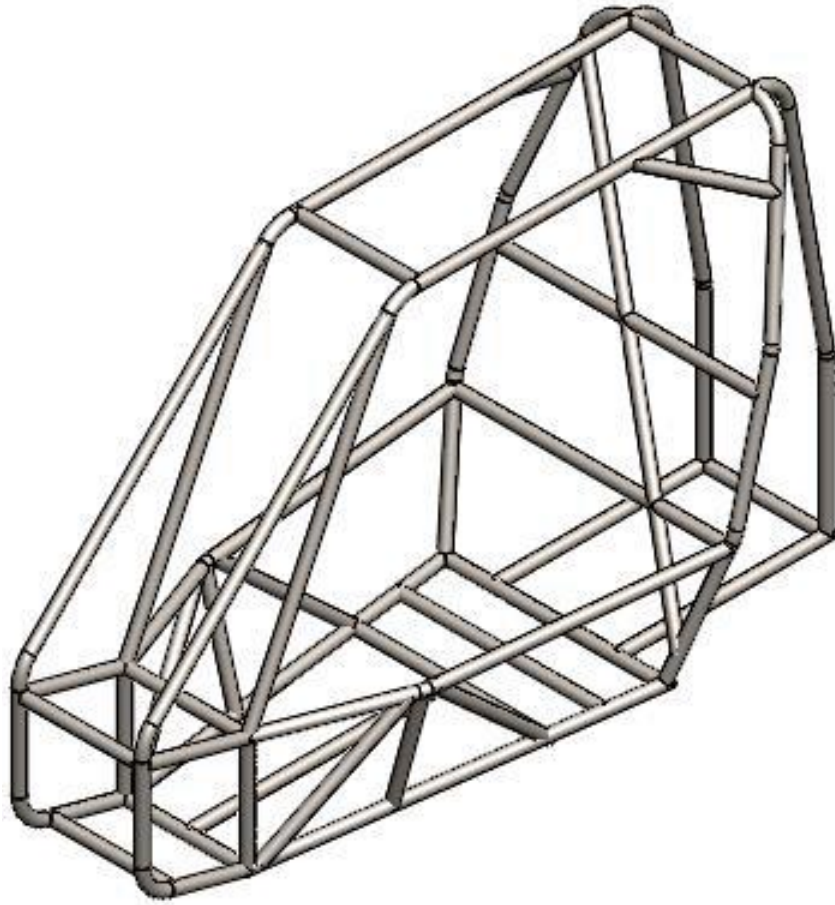

Figure 14: Isometric View of the Final Frame Design.

The material choices and dimensions changed from 1018 steel to 4130 chromoly steel due to it having a higher yielding strength. This higher strength allowed for a smaller cross-sectional area to be used, changing the members to a thinner wall thickness of tubing and decreasing weight.

Once this design was approved by our client, simulations were run again to make sure the integrity of the design was still acceptable. The table below, Table 5, shows a summary of the results while the actual results are found in the Appendix.

Table 5: Final Frame Simulation Results

| Test Scenario | Max. Stress (ksi) | Max. Deformation (in) | F.O.S. |
|-----------------|-------------------|-----------------------|--------|
| Drop Test | 30.3 | 0.452 | 2.2 |
| Front Collision | 17.1 | 0.037 | 3.9 |
| Rear Impact | 25.7 | 0.243 | 2.6 |
| Side Impact | 18.0 | 0.120 | 3.7 |

Frame Fabrication

To check the dimensions of the frame, a real scale PVC frame was made of the cockpit area. This PVC frame was used to determine how well a driver would sit within the frame while meeting all dimension safety requirements for the driver. The PVC frame can be seen in the figure below.

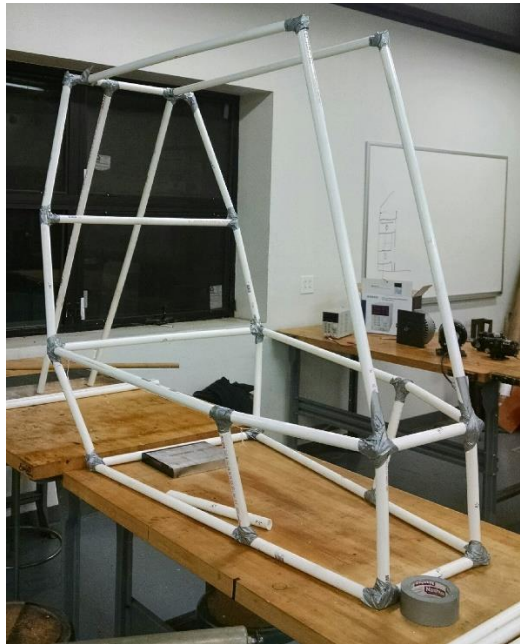

Figure 15: PVC Concept Frame

The fabrication of the frame began February 2, 2015. The team decided make the bottom supporting members (BSM) and the fire wall the backbone of the frame due to all the other members connecting to one of those two parts. To help with the cutting and bending, the team

was allowed access to the plotter in the NAU Engineering building to print full scale drawings of the frame. These drawings allowed the team to check dimensions and placement to ensure accuracy when tungsten inert gas (TIG) welding everything together. On Feb. 7th, the BSM were welded together. The following weekend, Feb. 14th, the firewall was welded to the BSM. Pictures of the BSM and the firewall are below in Figures 16 and 17.



Figure 16: Bottom Supporting Members



Figure 17: Firewall about to be TIG welded to the bottom Supporting Members

Following the sections being TIG together, the side impact member (SIM) was added next, along with some of the supports. The diagonal support for the firewall was added with another supporting secondary member for the SIM. This was all welded together Feb. 15th. The images can be viewed below in Figures 18 and 19.

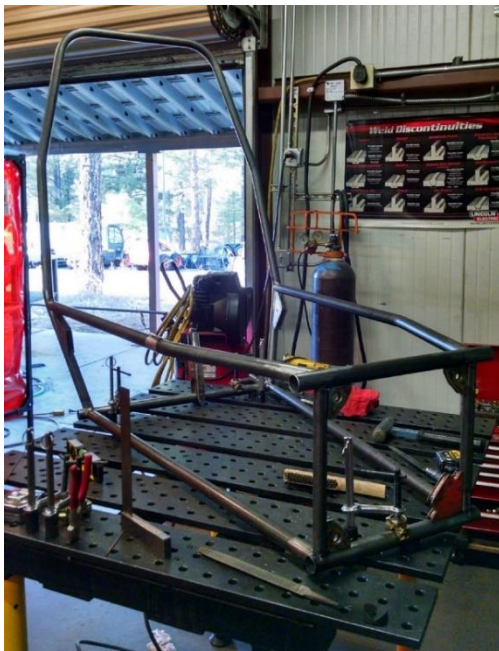

Figure 18: Side Impact Members being welded.



Figure 19: Diagonal Supports and SIM support added to the Frame.

The next members to be added to the frame were the roll hoops along with lateral spacing members. The lateral space members were welded to the roll hoops prior to being welded to the frame, allowing the roll hoop to be welded to the frame to be more precise. Next, the rest of the supporting members for the SIM were added to the frame as well. This all was done on Feb. 21st and 22nd. Unfortunately no photos were taken of the frame during this progress.

The last members to be added to the frame were the secondary supports for the roll hoop, primary members being added from the SIM to the roll hoop, making the SIM continuous to the roll hoop, and added supports from the fire wall to the roll hoops. This was all welded onto the frame on Feb. 28th, the images of the frame can be seen below Figures 20, 21, and 22.



Figure 20: Current Frame Progress.



Figure 21: Front View of the Current Frame.



Figure 22: Modified Seat Mount

Finished Frame

During the fabrication of the frame, the team decided to make a few modifications toward the frame. The first modification was applied to the mounting members of the seat. Due to certain advantages, the team decided to use a 1" 1018 steel square tubing with a thickness of 0.065" instead of 4130 Chromoly round tubing. Changing the member dimension from rounded tubing to square tubing allows for simple seat mounting and cuts weight due to no added tabs for mounting the seat, Figure 22: Modified Seat Mount. A similar change was also made for the mounting members for the transmission. The members were changed to 1.5" x 3" rectangular tubing with a thickness of 0.0747". The reason for making these changes from 4130 Chromoly to 1018 steel was due the fact that no manufacturers produce square or rectangular 4130 Chromoly tubing.

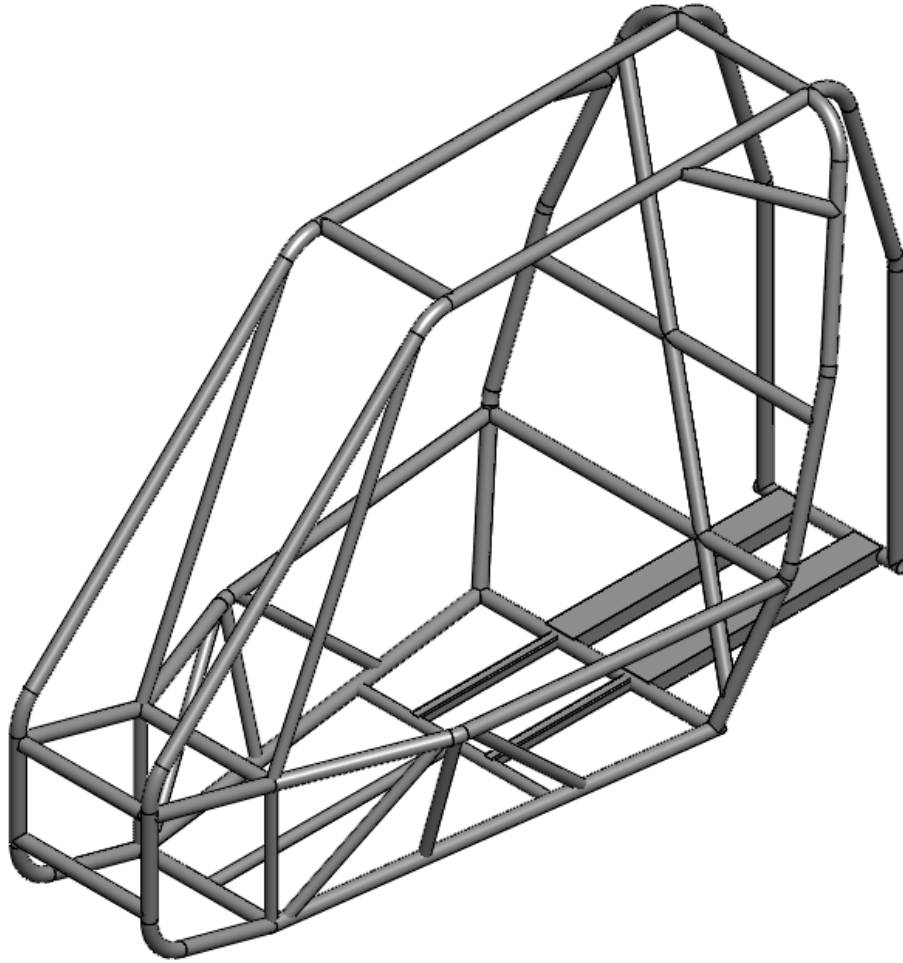

Figure 23: Isometric View of Updated Final Frame Design

Below is the finished fabricated frame with body panels.



Figure 24: Isometric View of Finished Frame.



Figure 25: Finished Frame

Cost Analysis

The team created a cost analysis based off the total material used in fabrication of the frame along with the amount of time needed to manufacture the frame. The table below goes over the total cost analysis for manufacturing a single frame.

Table 6: List of Raw Materials for building the frame

| Part Name | Cost (USD) |
|---------------------|------------|
| Roll Cage | 486.54 |
| Firewall | 23.75 |
| Body Mounts | 96.12 |
| Seat Mounts | 9.60 |
| Tube Caps | 17.84 |
| Transmission Mounts | 12.80 |
| Body Panels | 116.82 |
| Skid Plate | 3.13 |
| Total | 766.65 |

4130 steel tubing with a diameter of 1.25 inches and wall thickness of 0.065 inches was used for the main members of the frame. The 4130 steel tubing with a diameter of 1 inch and wall thickness of 0.056 inches was used to construct the secondary members of the frame. 1018 steel 1 inch square tubing was used for mounting the seat and 1.5 x 3 x 0.0747 inches rectangular tubing was used for mounting the transmission. In addition, 12 x 6 x 0.065 inches 1018 steel plating is used for making the tabs for panels. Aluminum sheet metal was used to build the required fire wall on the frame along with the body panels. HDPE sheeting was used for the skid plate. The total cost to manufacture the frame came out to be \$766.65. The following table shows the commercial parts that were purchased for driver safety.

Table 7: List of Commercial Parts need to compete.

| Part | Quantity | Cost (USD) |
|-------------------------|----------|------------|
| Safety Harness | 1 | 129.95 |
| Arm Restraint | 1 | 39.99 |
| Fire Extinguisher | 2 | 24.99 |
| Fire Extinguisher Mount | 1 | 64.95 |
| Neck Brace | 2 | 39.95 |
| Helmet | 2 | 83.50 |
| Goggles with Tear-Away | 2 | 28.67 |
| Fire Resistant Jacket | 1 | 59.95 |
| Seat | 1 | 39.97 |
| | Total | 689.03 |

All of the materials listed above are required for participating in the SAE competition. If the team is missing any of the items, the team would not be able to compete making this a non-negotiable budget of \$689.03. Multiples of some items were purchased due to there being more than one driver.

Table 8: Total Budget of the frame.

| Item | Cost |
|------------------|----------|
| Raw Materials | 766.65 |
| Commercial Parts | 689.03 |
| Total Cost | 1,455.68 |

Table 8 shows when adding the total cost for the needed raw materials and commercial parts together, the entire cost of the frame is \$766.65. Since there was no exact limitation on the cost to build the frame, this cost is deemed acceptable. Although, this is the cost to manufacture the frame, all of the metal was donated by Industrial Metal Supply in Phoenix, AZ.

Conclusion

The frame team was tasked to design and build a Mini Baja frame that would help outperform other Baja vehicles at competition. After communicating with the client, the team started designing various frame concepts that would be light in weight but still have a large amount of strength. After comparing concepts, two designs were chosen to be analyzed under a stress analysis. From the results of the analysis, the Front Bracing Frame was chosen as the base design to alter into a finalized design. After communicating with Dr. Tester and the other teams, the frame was then modified to incorporate the designs of the suspension and drivetrain. This led to a finalized version of the frame that is 110lbs and yields a factor of safety of 2.2 during a drop test.

The construction of the frame started February 2nd. The frame was built from different types of tubing; 1.25 x 0.065 inches round tubing of 4130 chromoly steel, 1 x 0.035 inches round tubing of 4130 chromoly steel, 1 x 0.065 inches square tubing of 1018 steel, and 1.5 x 3 x 0.0747 inches rectangular steel tubing. The frame team used the fabrication building, building 98C, to fabricate the frame. The frame was then TIG welded, rather than MIG welded together, due to TIG welding being lighter in weight. During the fabrication of the frame, changes were made to the seat mounting members along with members for mounting the transmission. Once the frame was constructed, tabs were added for the suspension, firewall, body panels, and skid plate and Tabs were then added to the frame for suspension, firewall, body panels, and skid plate to complete construction of the frame.

The frame has progressed well and is nearly complete. The total projected cost to manufacture the frame and safety equipment came to a total cost of \$1,455.68. The last step is to finish all the last minute modifications for ergonomics to the vehicle and test it by the middle of May to compete in Portland, Oregon on May 26, 2015.

References

- [1] K. Nam-Ho, "Introduction to Finite Element Analysis and Design" 2008, Wiley.
- [2] SAE International, "2015 Collegiate Design Series Baja SAE Rules" 2014, 2014.
- [3] A. T. Owens, "Structural considerations of a Baja SAE frame," 2006-12-05, 2006.
- [4] NAU SAE Baja 2013-2014
- [5] SAE Design and Analysis Project with SolidWorks Software
- [6] SAE Mini Baja Frame Analysis 2013
- [7] <http://www.superatv.com/Polaris-Ranger-XP-900-6-Lift-Kit-P8182.aspx>, access 2014.
- [8] <http://socalbajas.com/>, access 2014.
- [9] 2015 Collegiate Design Series Baja SAE Rules

Appendix

Appendix A: Front Supporting Deformation Simulation Results from Drop Test.

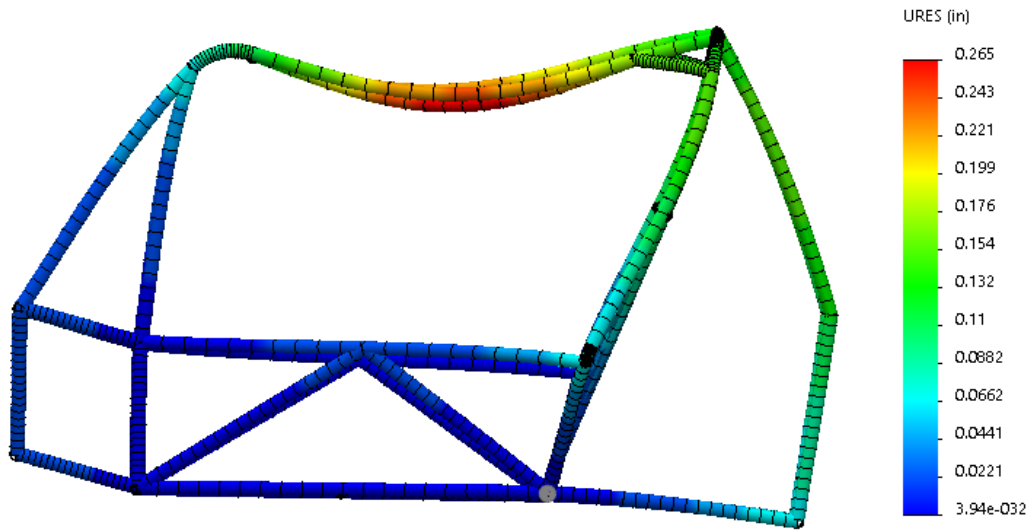

Appendix B: Front Supporting Stress Simulation Results from Drop Test.

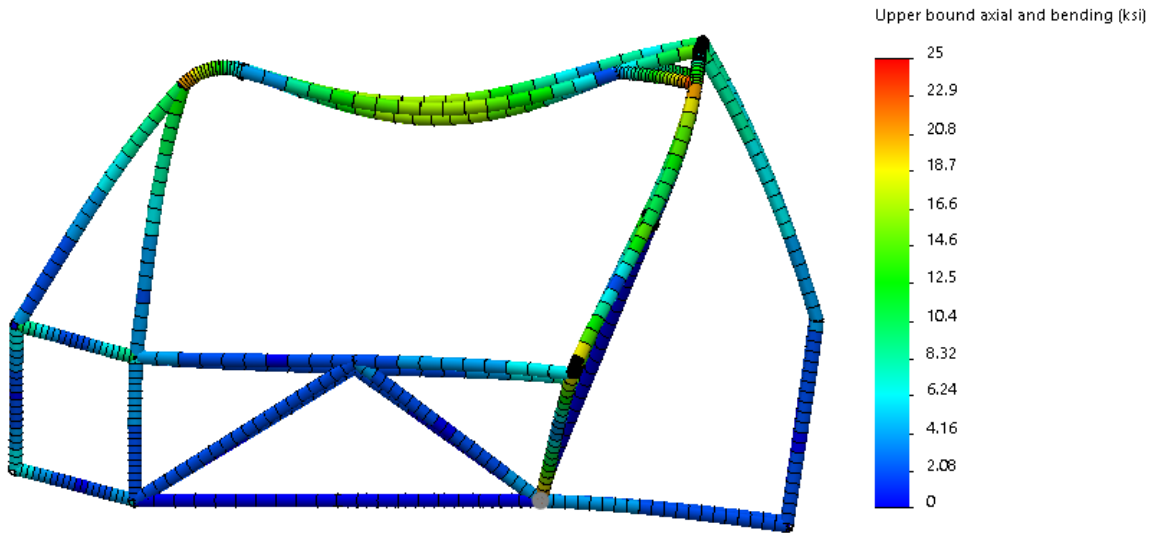

Appendix C: Front Supporting Deformation Simulation Results from Front Impact Test.

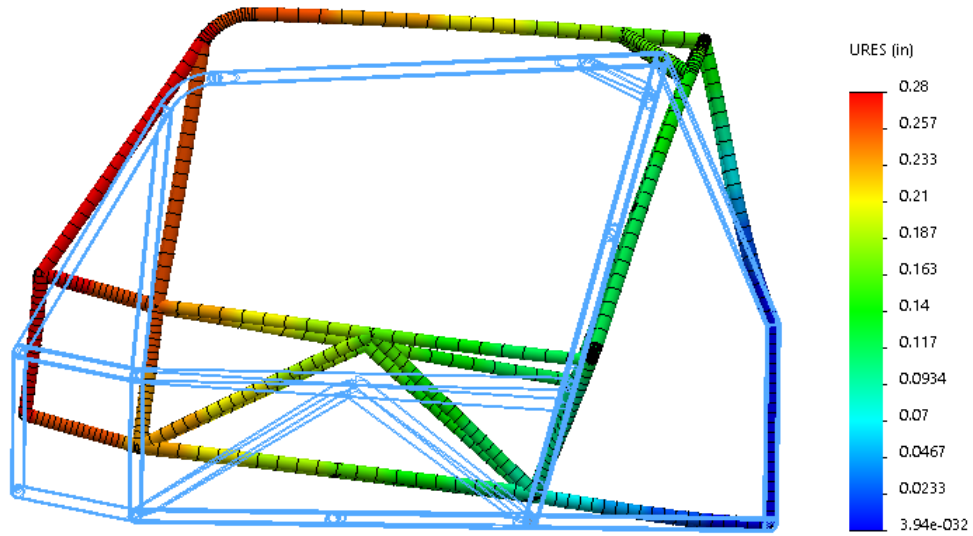

Appendix D: Front Supporting Stress Simulation Results from Front Impact Test.

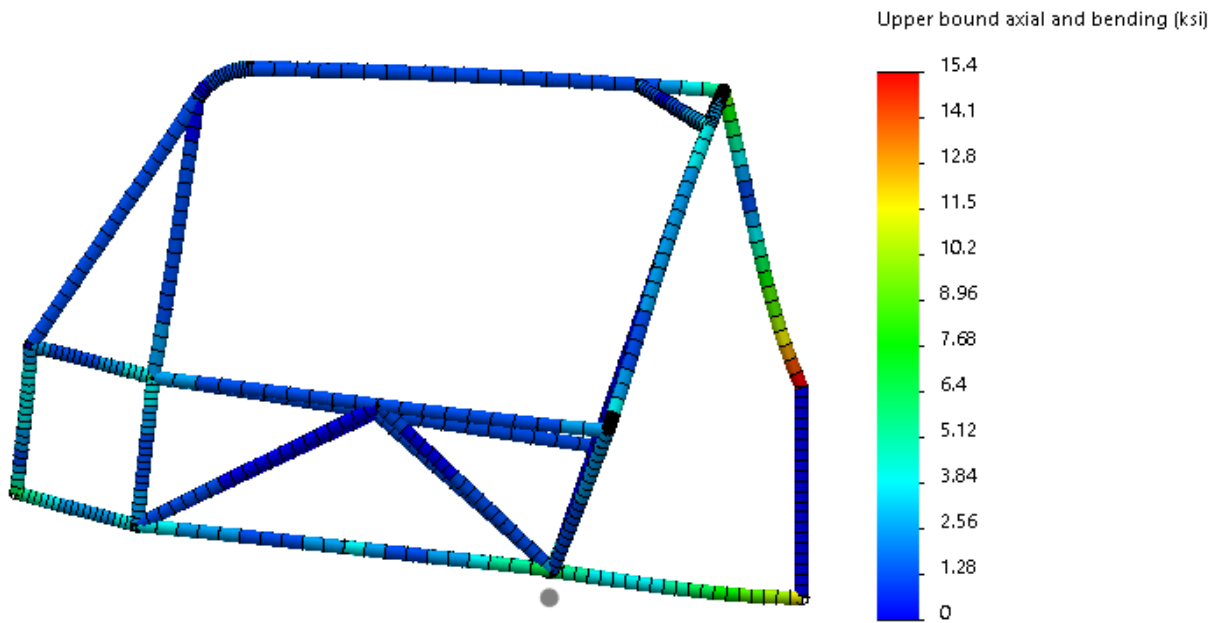

Appendix E: Front Supporting Deformation Simulation Results from Rear Impact Test.

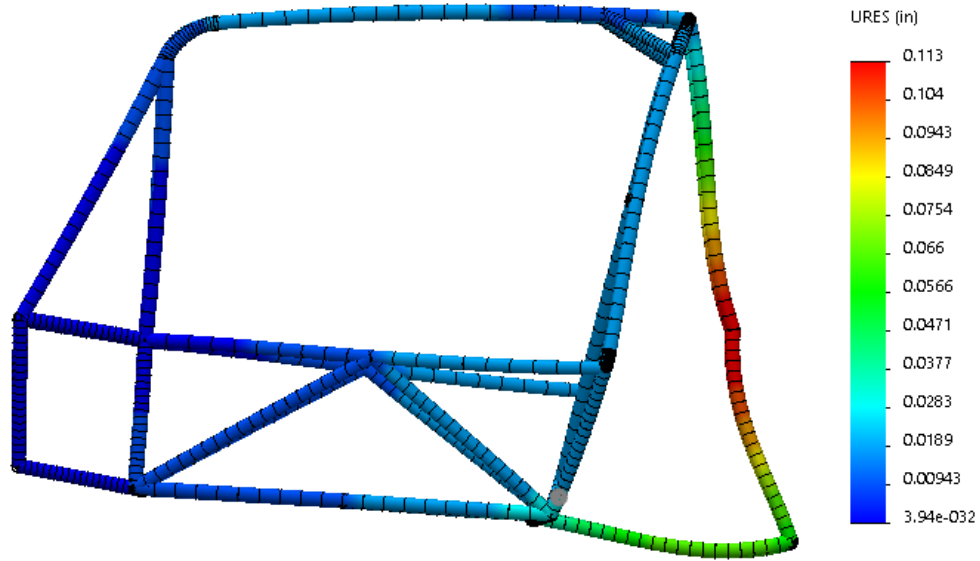

Appendix F: Front Supporting Stress Simulation Results from Rear Impact Test.

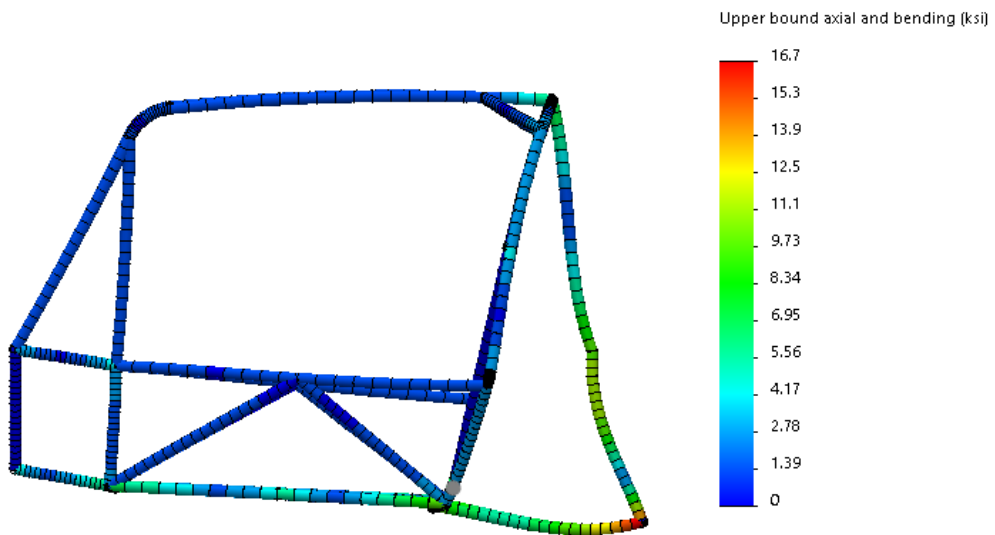

Appendix G: Front Supporting Deformation Simulation Results from Side Impacting Test.

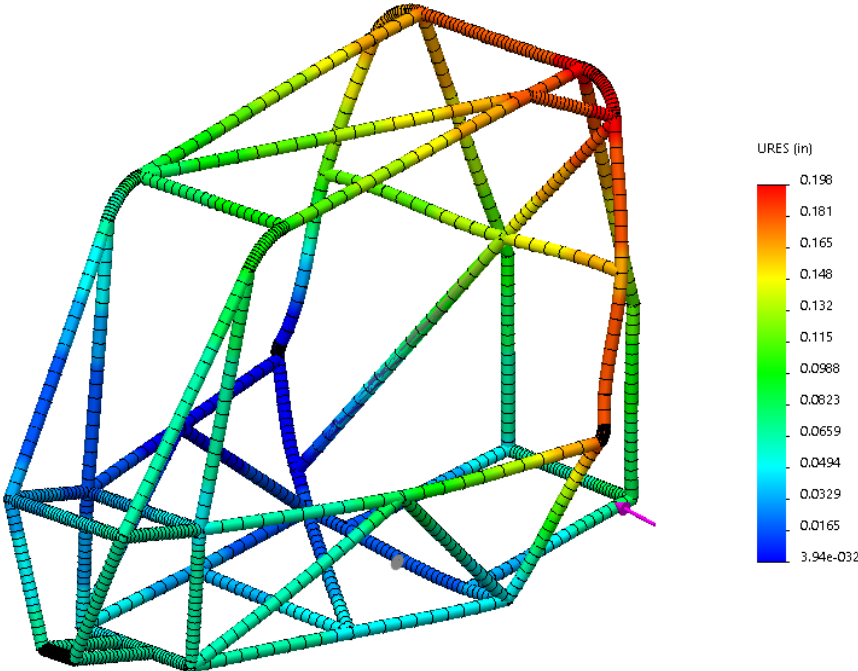

Appendix H: Front Supporting Deformation Simulation Results from Side Impacting Test.

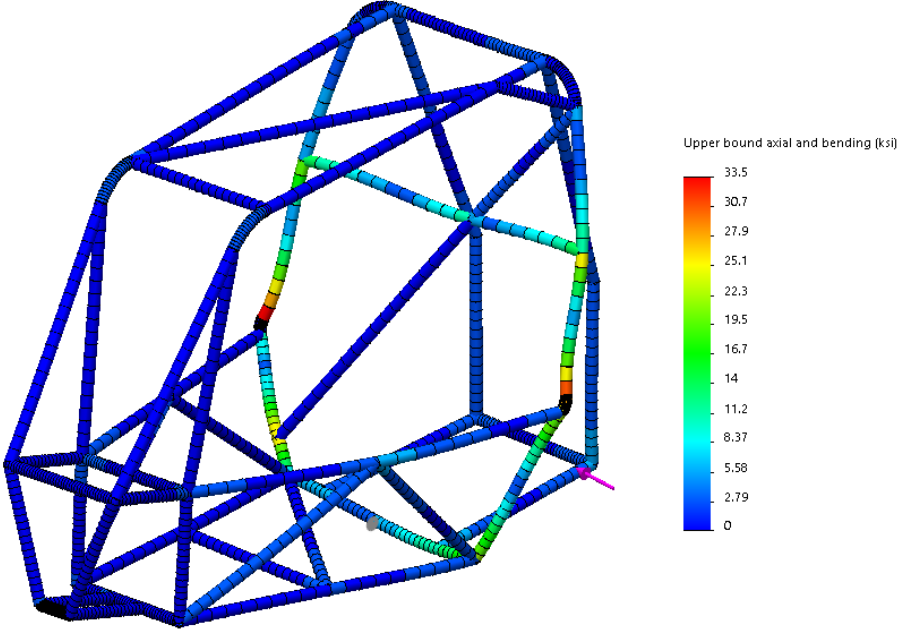

Appendix I: Front Bracing Deformation Simulation Results from Drop Test.

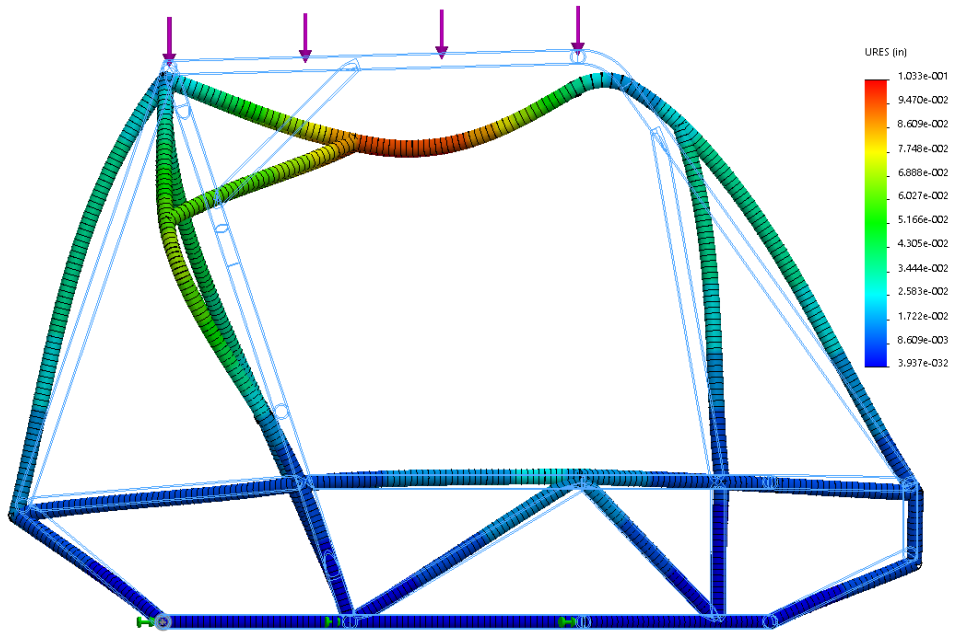

Appendix J: Front Bracing Stress Simulation Results from Drop Test.

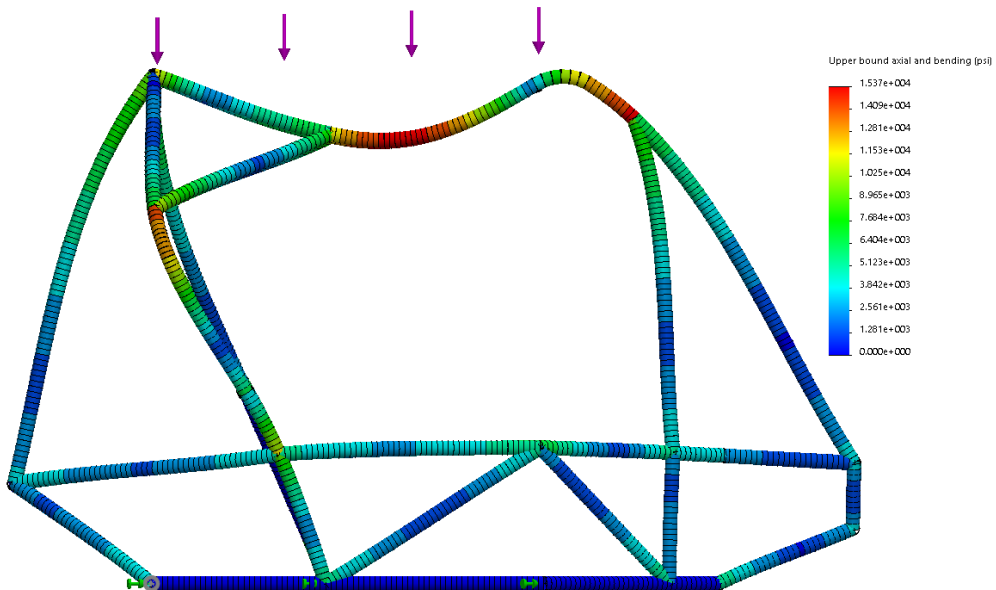

Appendix K: Front Bracing Deformation Simulation Results from Front Impact Test.

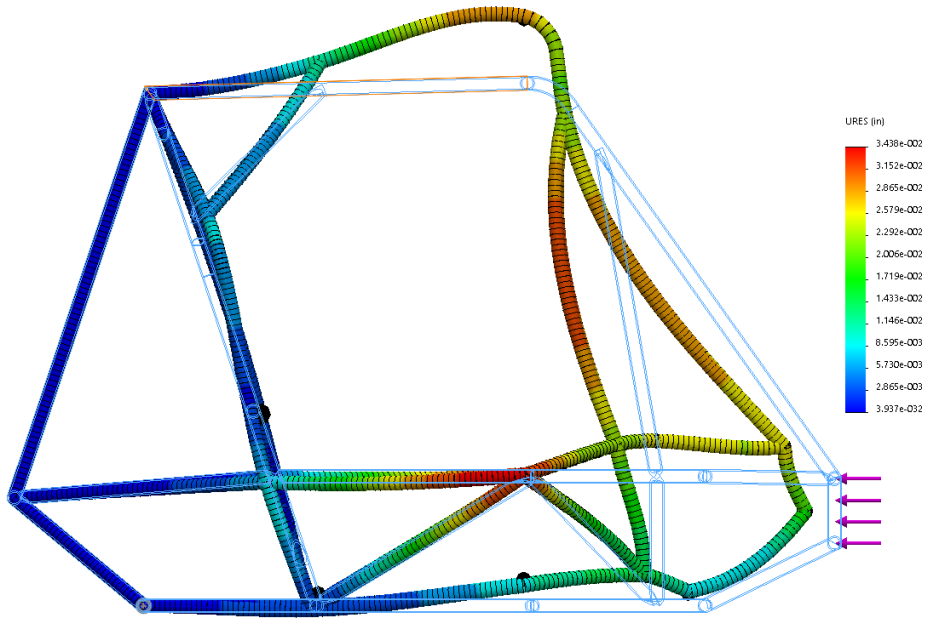

Appendix L: Front Bracing Stress Simulation Results from Front Impact Test.

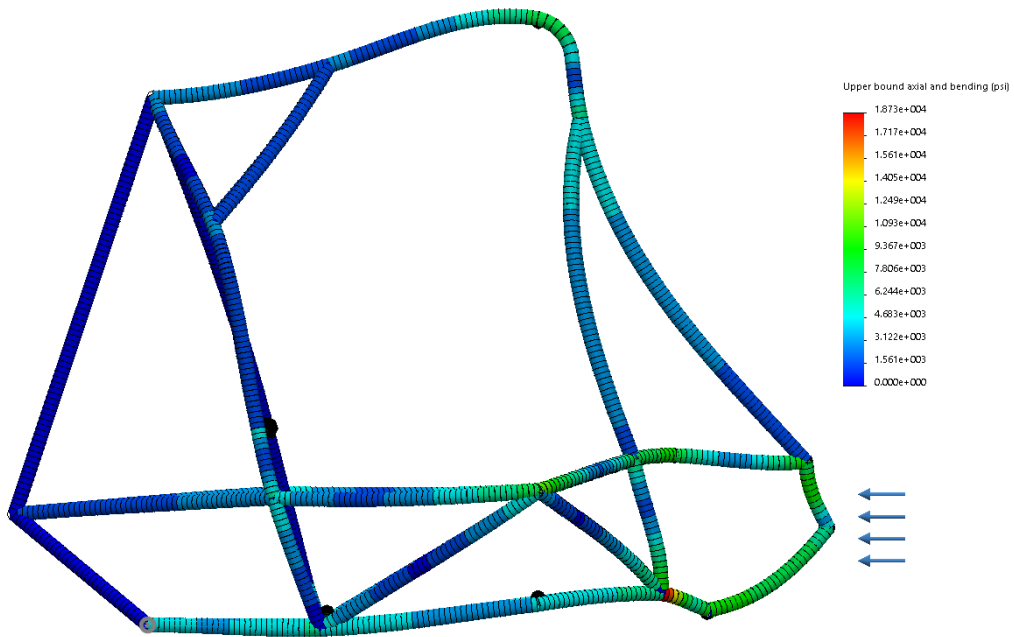

Appendix M: Front Bracing Deformation Simulation Results from Rear Impact Test.

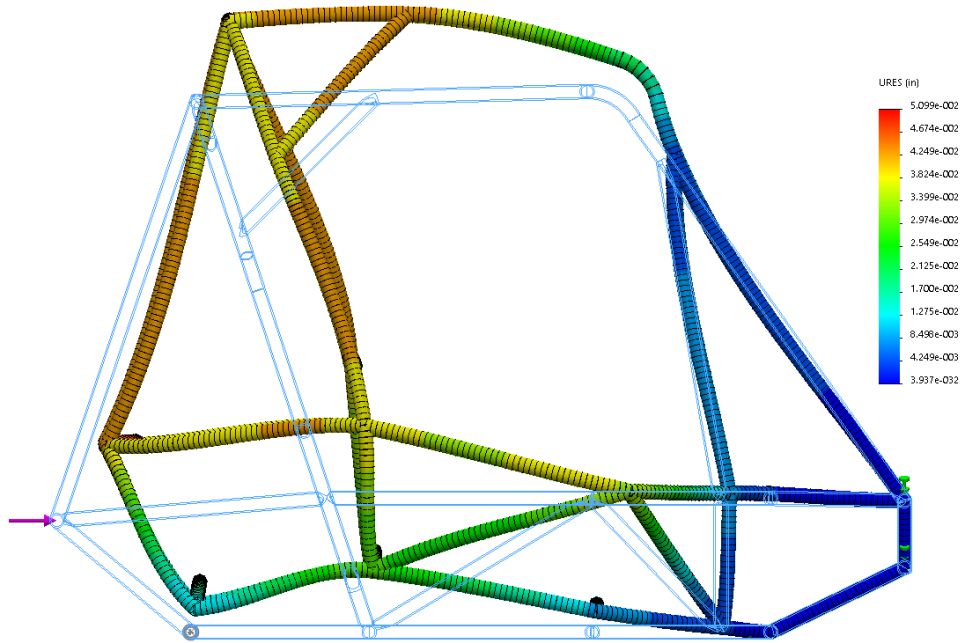

Appendix N: Front Bracing Stress Simulation from Rear Impact Test.

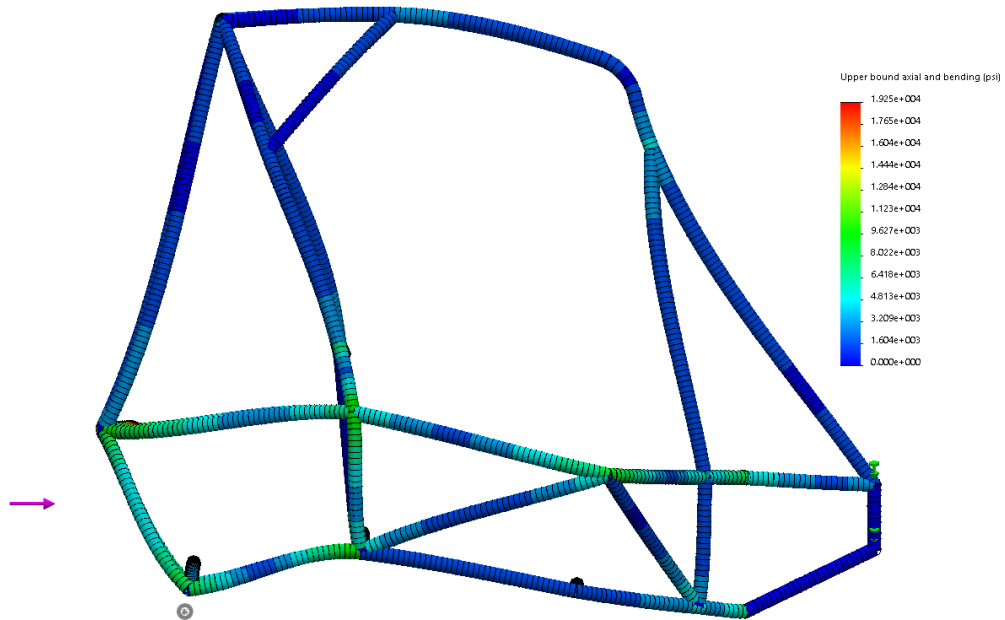

Appendix O: Front Bracing Deformation Simulation Results from Side Impact Test.

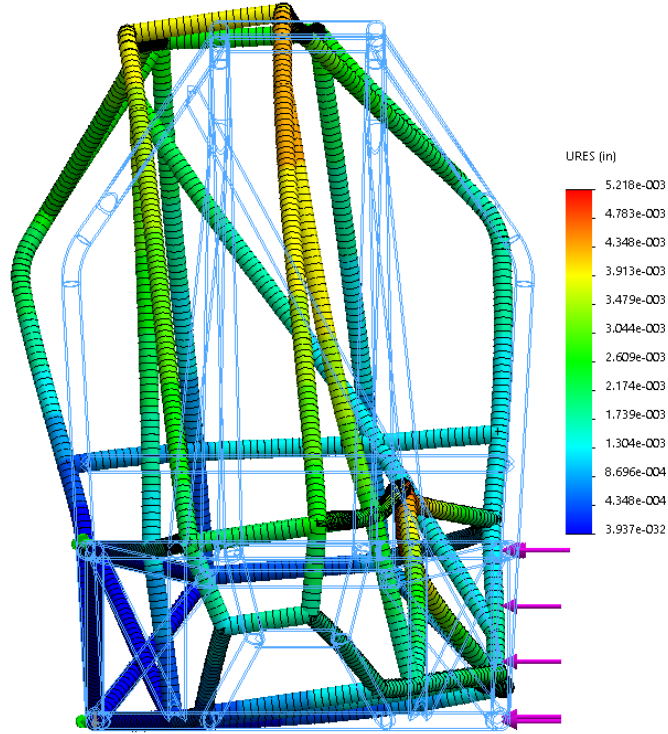

Appendix P: Front Bracing Stress Simulation Results form Side Impact Test.

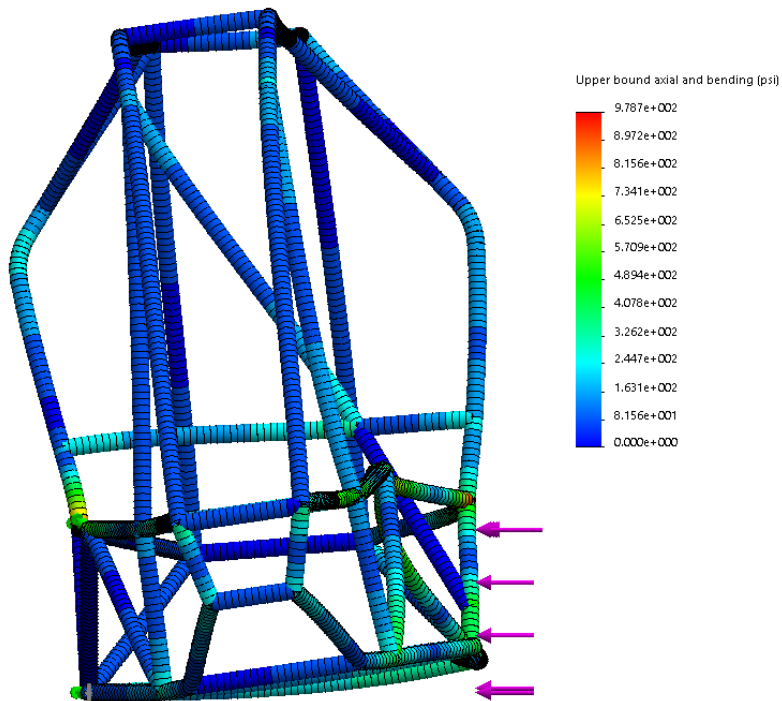

Appendix Q: Final Design Deformation Simulation Results from Drop Test.

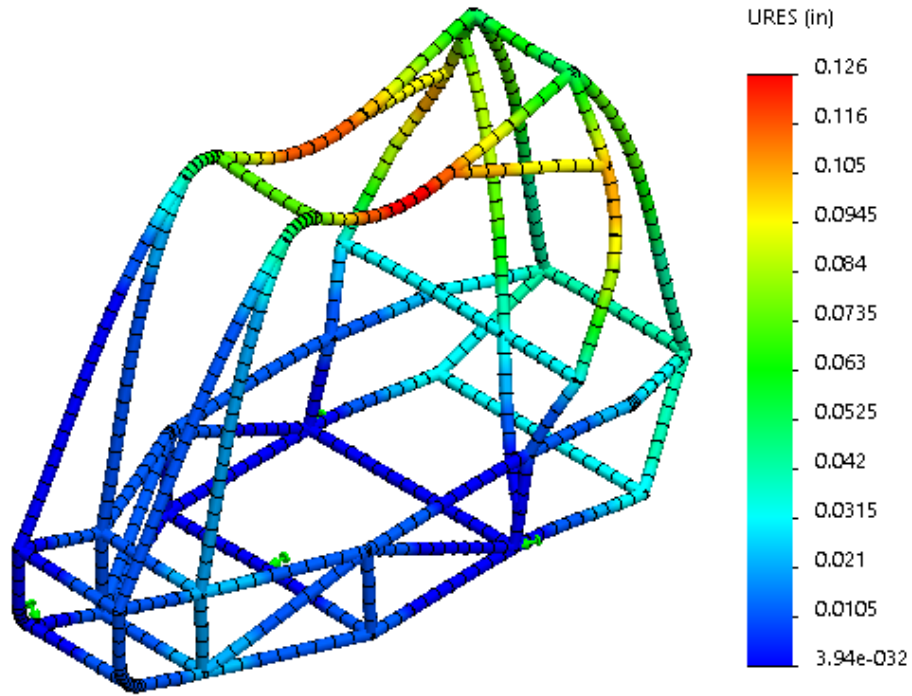

Appendix R: Final Design Stress Simulation Results from Drop Test.

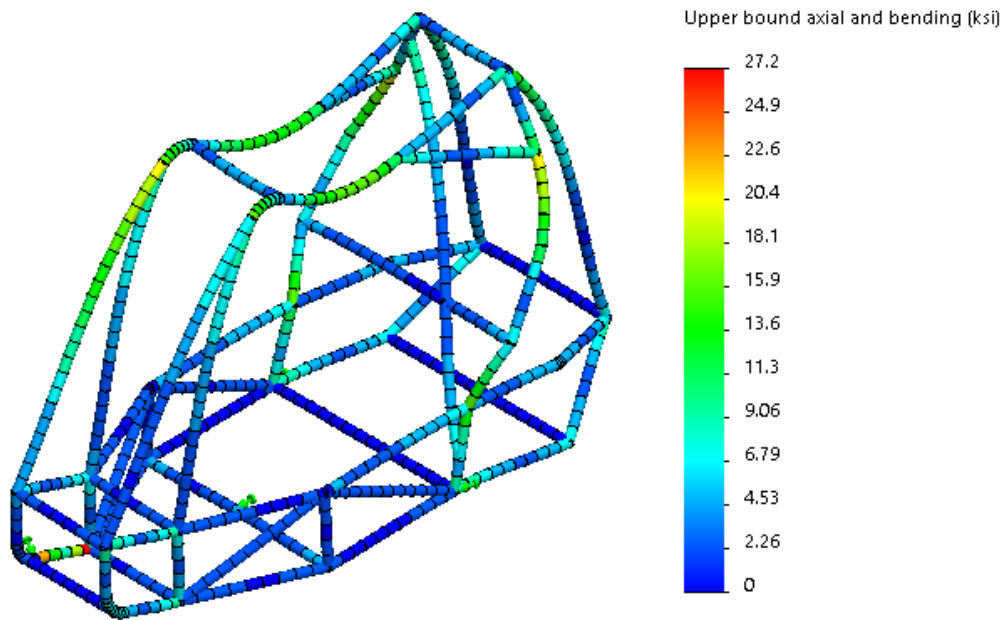

Appendix S: Final Design Deformation Simulation Results from Front Impact Test.

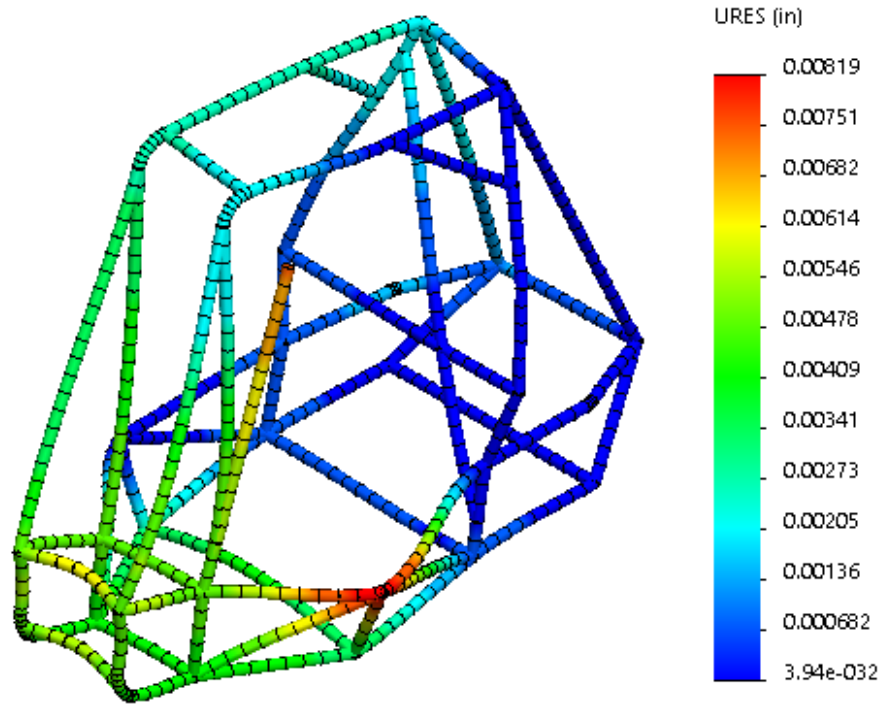

Appendix T: Final Design Stress Simulation Results from Front Impact Test.

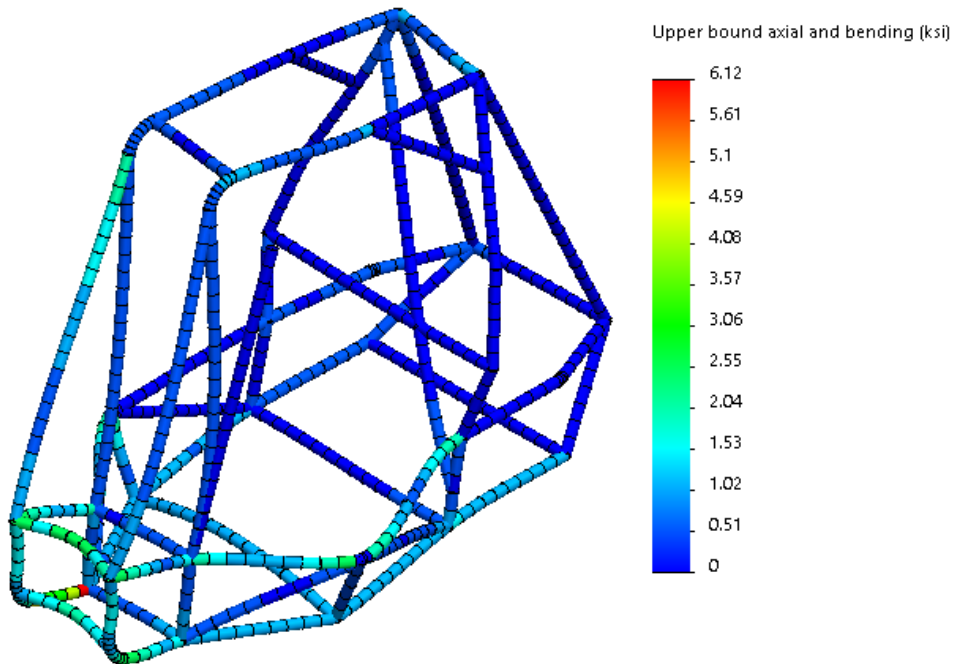

Appendix U: Final Design Deformation Simulation Results from Rear Impact Test.

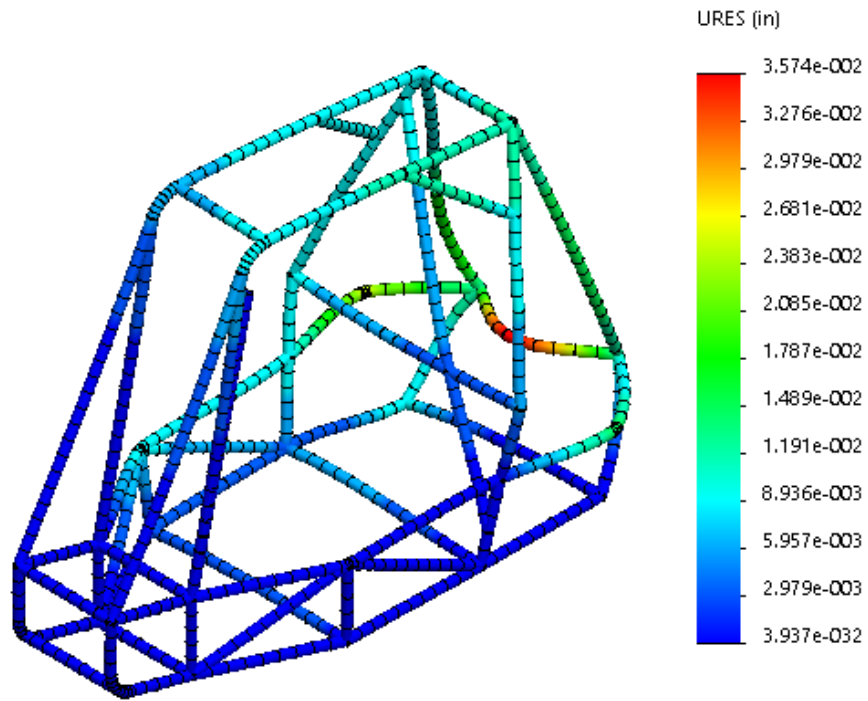

Appendix V: Final Design Stress Simulation Results from Rear Impact Test.

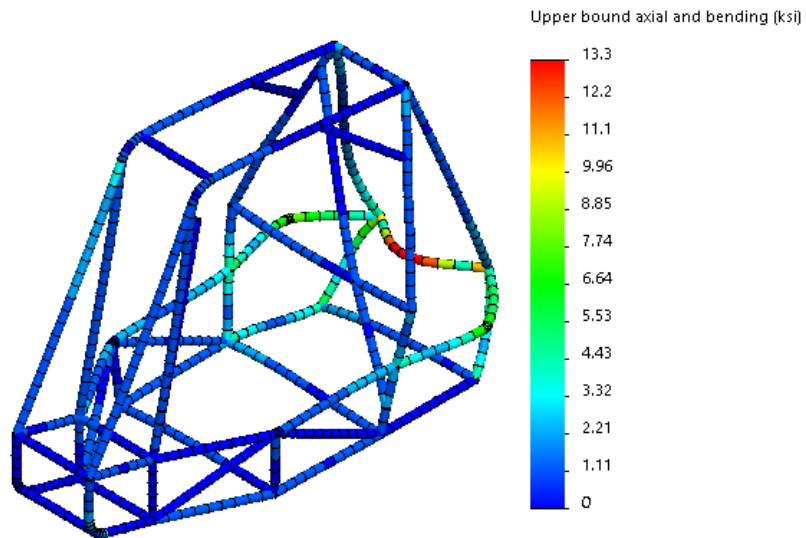

Appendix W: Final Design Deformation Simulation Results from Side Impact Test.

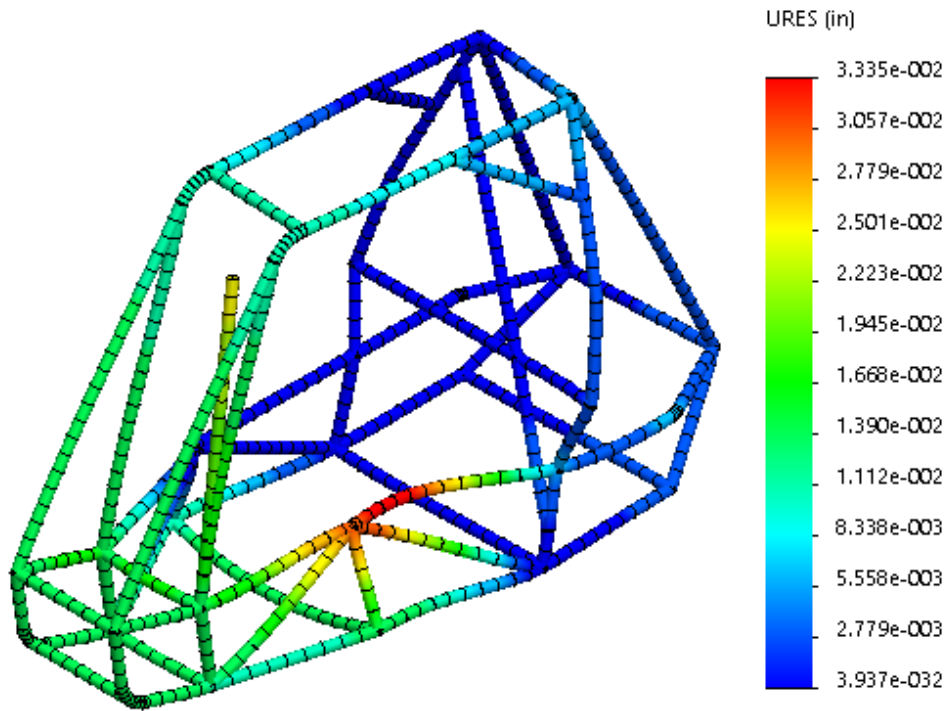

Appendix X: Final Design Stress Simulation Results from Side Impact Test.

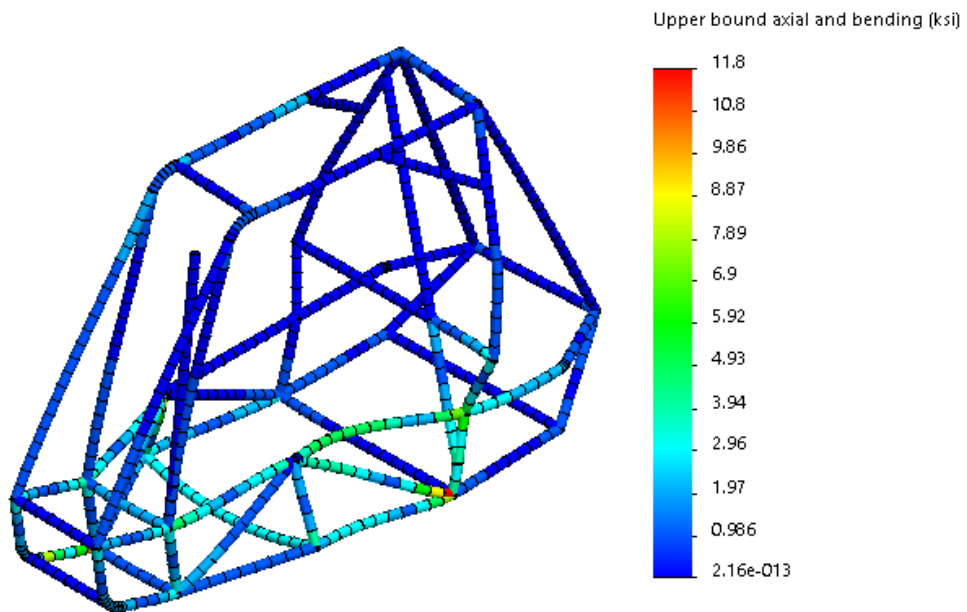

Appendix Y: Top View.



Appendix Z: Front View.



Appendix AA: Side View.

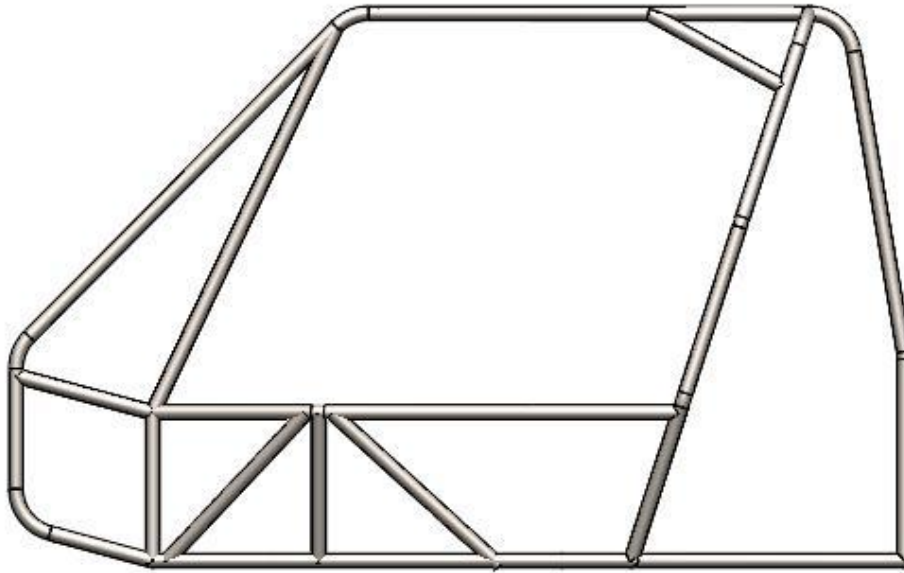

Appendix BB: Drop Test Deflection.

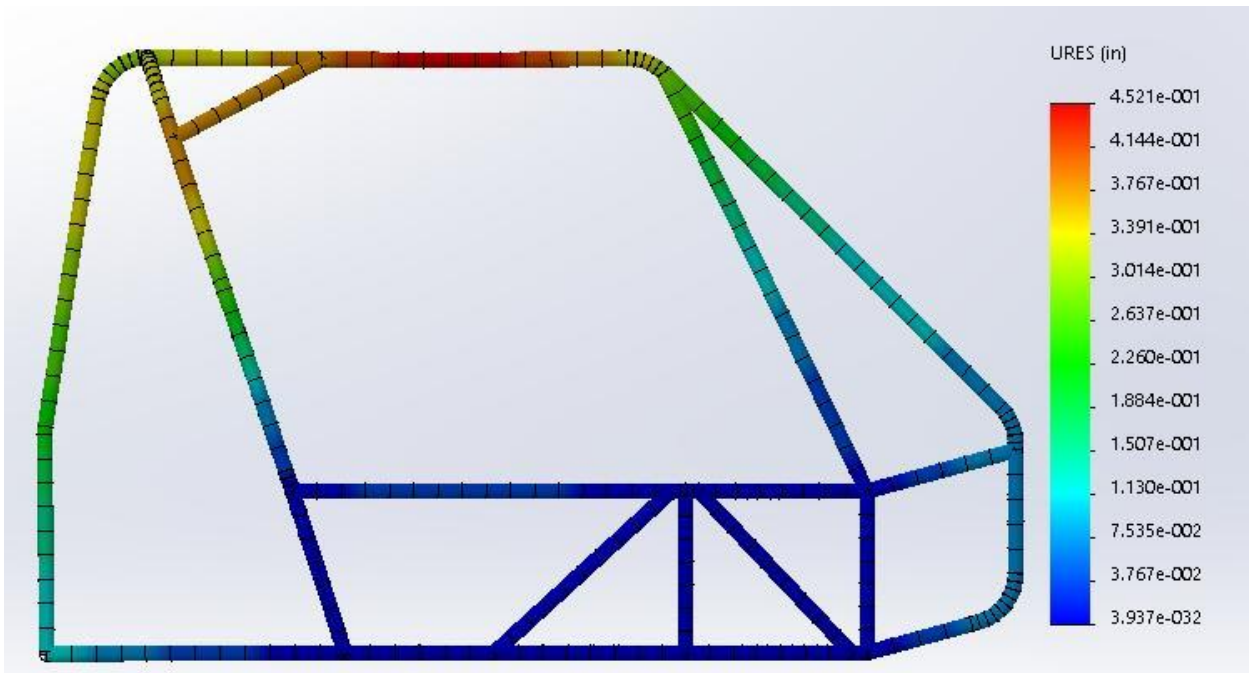

Appendix CC: Front Impact Test.

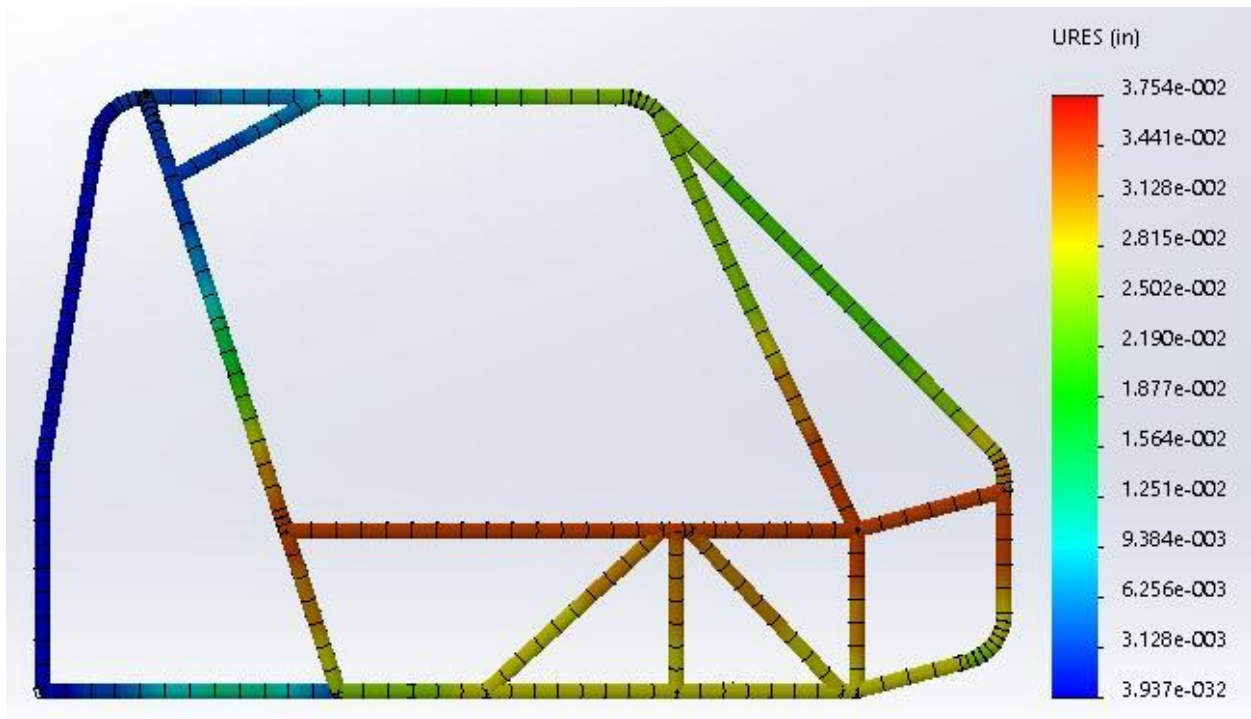

Appendix DD: Rear Impact Test.

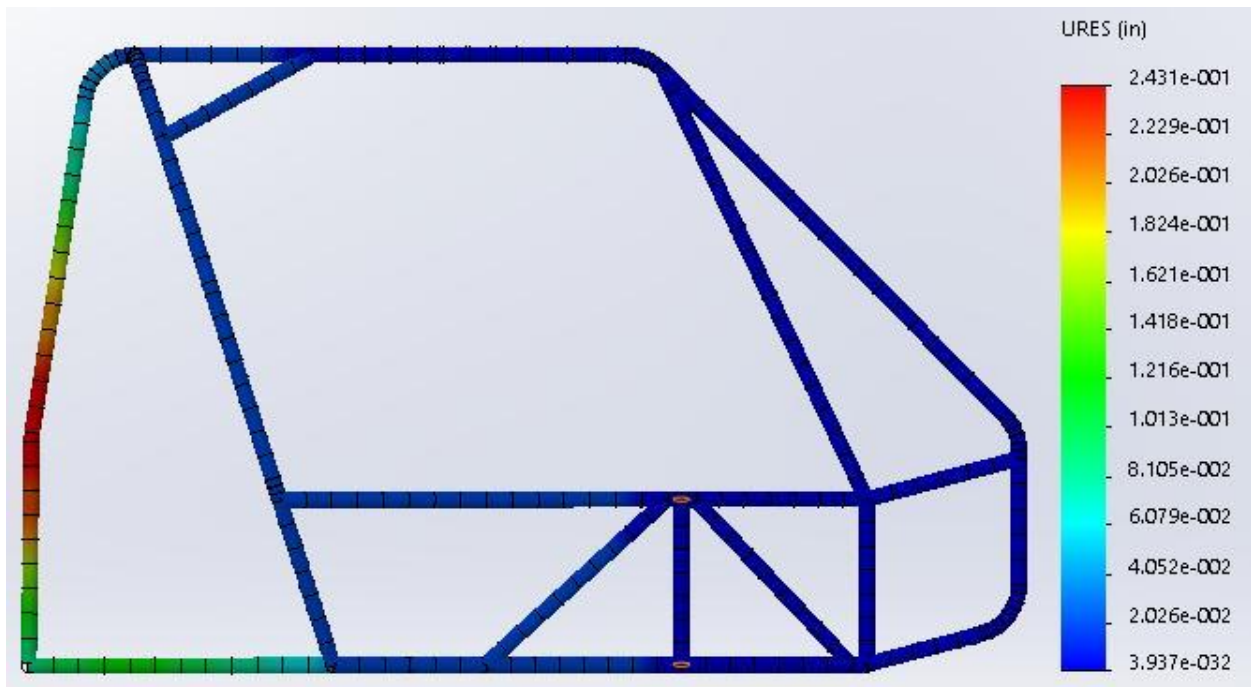

Appendix EE: Side Impact Test.

