

Mechanical Shredder

By

Ryon Baloo, Kendall Meyer, Mohammed Molani,
and Sultan Alshahrani

Team 10

Project Proposal

Document

*Submitted towards partial fulfillment of the requirements for
Mechanical Engineering Design I – Fall 2014*



Department of Mechanical Engineering

Northern Arizona University

Flagstaff, AZ 86011

Table of Contents

Executive Summary	2
Statement of Problem.....	2
Goals, Objectives, and Constraints	2
Testing Environment.....	3
Technical Approach	4
Quality Function Deployment (QFD).....	4
House of Quality (HOQ).....	5
Project Planning	6
Design Concepts Introduction.....	7
Decision Matrix Criteria	15
Averaged Group Decision Matrix.....	16
Chosen Product	17
Engineering Analysis	18
Existing Mechanism.....	18
Retrofit Design.....	19
List of Parts and Prices	21
Conclusion	22
References.....	23

Executive Summary

Present day paper shredders are electric driven with sensors that operate the system when paper is detected. The goal of our team is to design a mechanical driven paper shredder that can either be leg or hand operated. The criteria for our design include: Visibility, Meets Client Priorities, Economic Feasibility, Program Longevity, Reasonable Timeline, and Impact for Third World countries or areas that have limited access to electricity.

Statement of Problem

Tossing important documentation in trash bins is not enough to prevent stolen ideas, identities, and frauds. Schools or companies can have their personal information exposed to random individuals and made accessible to the public. Unlike the United States, Third World countries have limited access to electricity; therefore, they do not have to pay about \$65.00 /year on operating an electric shredder at \$0.12 per kW/hr. This will lead to emitting greenhouse gases into the atmosphere [1]. The disadvantage of not having electricity is the not properly disposing of important information. The disadvantage of using electricity to operate an electric shredder is dealing with possible power outages. It will occur at the most crucial time, preventing an individual from destroying their documents.

These are all potential aspects we have to consider in dealing with an electrical shredder. That is why our team will assist those in need of disposing credit cards, tax returns, company research, and CD files with a mechanical paper shredder. This eliminates the dilemma of dealing with electricity altogether.

Goals, Objectives, and Constraints

The ultimate goal is to design a mechanically operated shredder that holds no source of electrical components and is human driven. Our team is to research and communicate with our client to perfect our design accurately. Below is the outline for the specific project goals, objectives, and constraints that show relation to designing the mechanical shredder.

Goals

- Mechanical shredder needs to be highly reliable, and portable.
- Environmentally friendly system.

- Mechanically operated with no electrical sources.

Objectives

- Competes with present-day electrical paper shredders.
- Has a container to hold shredded paper.
- Mechanical shredder has to be inexpensive.
- Shreds paper with minimum muscle strain (leg or hand operated).
- System has to be able to shred paper, credit cards, and CDs.
- The system has to be wall mounted or be able to stand alone.

Constraints

- Total design cost must be less than \$100.00.
- Mechanical system needs to shred at maximum 10 sheets per feed.
- Operate and shred 36 pages per minute.
- Required paper size is a standard 8.5 inches by 11 inches or less.
- Volume of system is 5ft³.
- To operate at a noise level that is less than 65 decibel (dB).

Testing Environment

When testing the product, the mechanical paper shredder must fit in an average office with a space of 5ft³ and have wall space to mount the shredder within. When running the test, there are four essential data to analyze and collect:

- The mechanical system's runtime (how long the system takes to operate).
- How quickly the system shreds one piece of paper.
- The amount of paper the system can shred in one feed.
- Determine if the design is silent enough for an office environment.

Technical Approach

The technical approach for this proposal involves identifying customer needs by using a quality function deployment, house of quality, project planning, and designing a mechanical shredder concept for this semester. The quality function deployment, house of quality, and project planning are described in order in the following paragraphs. Designing a mechanical shredder concept is determined by applying an averaged group decision matrix based off of eight design concepts and selecting the two final designs.

Quality Function Deployment (QFD)

Two competitors that we looked into for a mechanical paper shredder was the Premium Connection Paper Shredder shown in Figure 1, and the Manual Paper Shredder developed by IDEA as shown in Figure 2. Both of these mechanical paper shredders are fully mechanical, but are not reliable enough. These shredders are close to novelty items and the client asked our group to develop a reliable mechanical paper shredder that is going to be used continuously in a busy office environment. These two shredders are the common types of mechanical shredder that you can find on the internet.



Figure 1: Competitor 1: Premium Connection Paper Shredder [2]



Figure 2: Competitor 2: Manual Paper Shredder from IDEA[3]

As shown in our Quality Function Deployment (QFD) (Table 1), both competitors do not properly meet with our customer requirements. They are not reliable systems and not durable enough for the office use that is requested for this project. Trends in our QFD shows that our system has to have a focus on reliability, being inexpensive, but also being cost effective. We can focus on meeting these customer requirements by focusing on the weight and size of the system and makes sure it performs its required tasks of being able to shred 36 pages per minute, and being able to shred at least 10 sheets of paper in one cycle.

Table 1: Quality Function Deployment

		Engineering Requirements							Competitors		
		Weight	Volume	Cost	Noise Level	Speed	Pages at a Time	Shred Width	Bin Capacity	Product 1	Product 2
Customer Requirements	Minimum Carbon Footprint		X								
	Reliable					X	X	X			
	Inexpensive	X	X	X					X	O	O
	All Mechanical System				X	X				O	O
	Cost Effective			X		X	X			O	
	Units	lbs	ft ³	\$	db	Pages/Min	x Pages/Iteration	inches	gallons		
		20-25	5	100	65	36	10	0.25	5.25		

House of Quality (HOQ)

Our House of Quality (Table 2) shows the common trends that we will encounter when designing and fabricating this system. As the weight of the system goes up, that could possibly lead to an increase of volume, however we could increase the size of the paper collection bin. If we decide to build a bigger system that could potentially add to our cost. The categories such as: noise level, speed, pages at a time, and shred width, all factor into the reliability of the system. Being limited to \$100.00 and a 5ft³ volume, we have to find a way to maximize reliability while keeping to our given constraints.

Design Concepts Introduction

To begin our design concept and generation stage, each team member was assigned to create two design concepts of their own for our mechanical paper shredder. We set no restrictions, other than that it had to be a process that was completely mechanical. The team members had to come up with a full system for their designs. This would include: a paper shredding mechanism/system, a bin/storage system, and some way to dispense of the paper shreds when the system became full. Together, we came up with eight designs for the mechanical paper shredder system.

Design 1

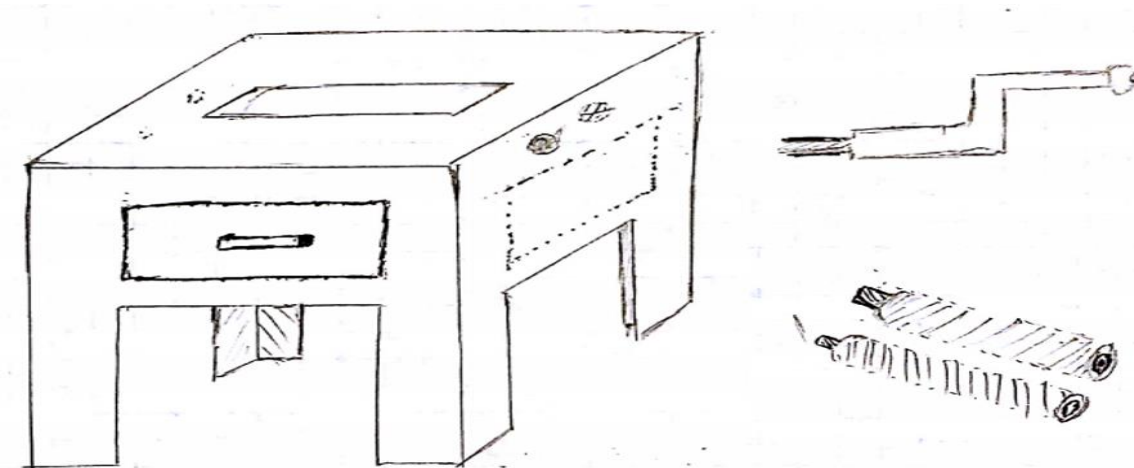

This design concept is based off of the night stand. There are two gearing systems that rotate and shred the recommended materials. While one gear is stationary and the other is being rotated by a hand crank, the paper is inserted from the top of the design. On the front side of the design, there is a drawer to dispense wasted material. This allows the users easy access to determine what is causing the mechanical shredder to jam. This design is very portable and can be moved around an office space so as not to get in the way of the user. However, when operating the shredder, it may jam due to the stationary gear that is set in place.

Design 2

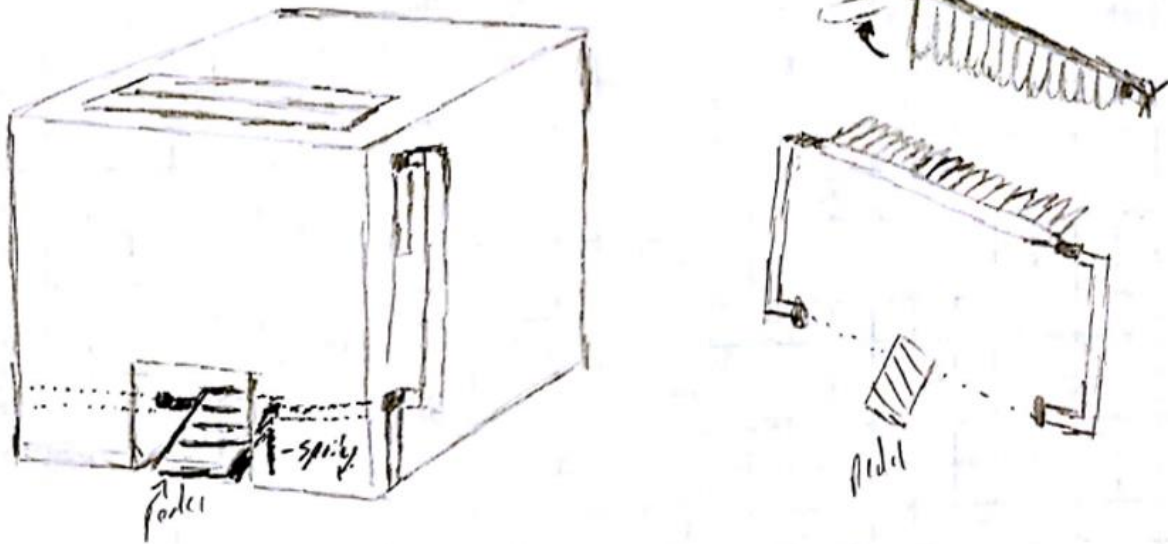

The following design is operated similar to a shear system, however used with a foot pedal. Once the user pushes down on the foot lever; the shears disengage and cuts the recommended material that is inserted through the top of the mechanical box. There are a couple of shears that will operate this mechanism. One is positioned to the container while the other operates. The springs that are placed underneath the foot pedal will recoil the shears to its original position once the user removes their foot. This design will most likely jam depending on what the user is trying to shred. The user can remove the shredded material by opening the backside and taking out the bin container

Design 3

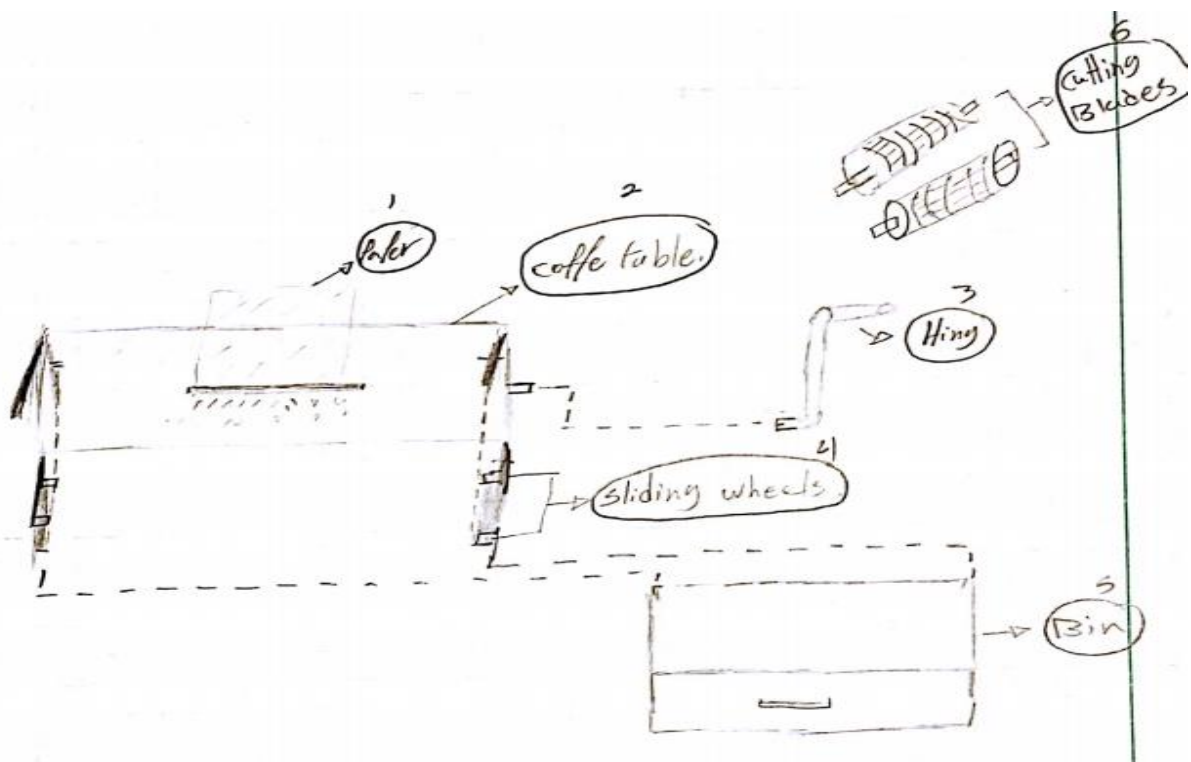

This design is a combination of a coffee table and a paper shredder. The system is a multi-directional cross bladed shredder that can allow a multiple sheets of paper to be shredded per feed. It has a big bin size that can carry a large amount of shredded items. The bin is easily accessible because it is a drawer system that pulls out of the main body, so the waste can be disposed of quickly and efficiently. When shredding items, the system remains stable and silent to maintain a quite working environment through the use of the hand-crank mechanism. The table also fits into an office environment and can be used to keep drinks on, and even decorate.

Design 4

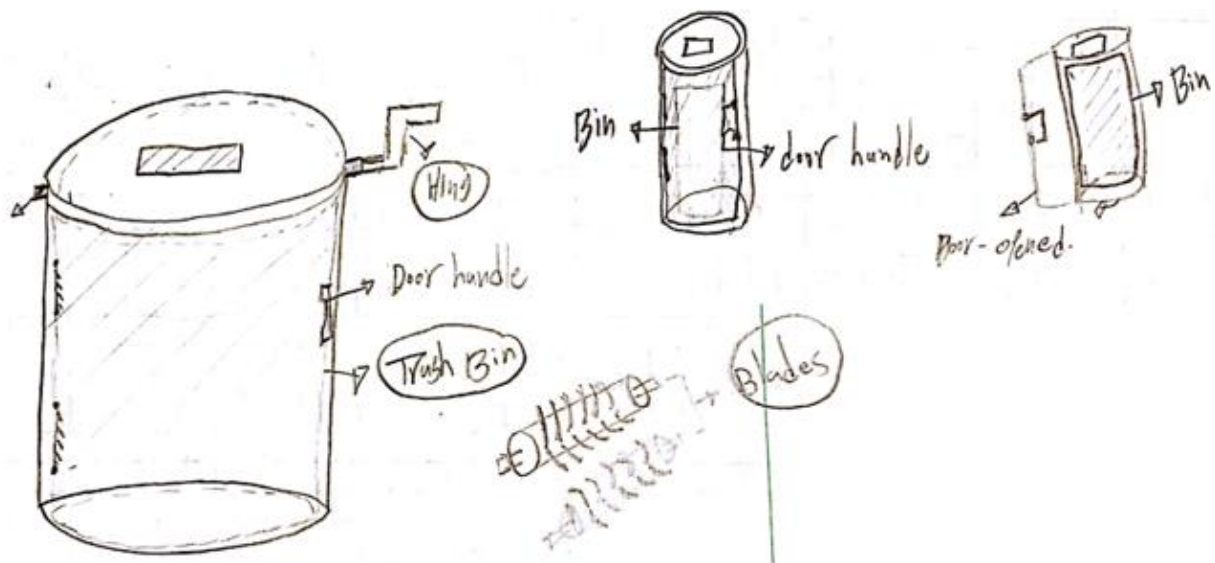

The design is based on a simple trashcan. Almost the entirety of the container can be used to store waste, with the exception of the space the shredding mechanism takes up at the top of the system. The bin can be emptied by taking off the top, so a garbage bag can be removed or the system can be directly tipped over and disposed of. If need be, a side door can be attached to the system so no lifting of the entire mechanism is necessary. The system is designed to be durable and light-weight, so it might be unstable when using the hand-crank to rotate the shredding mechanism.

Design 5

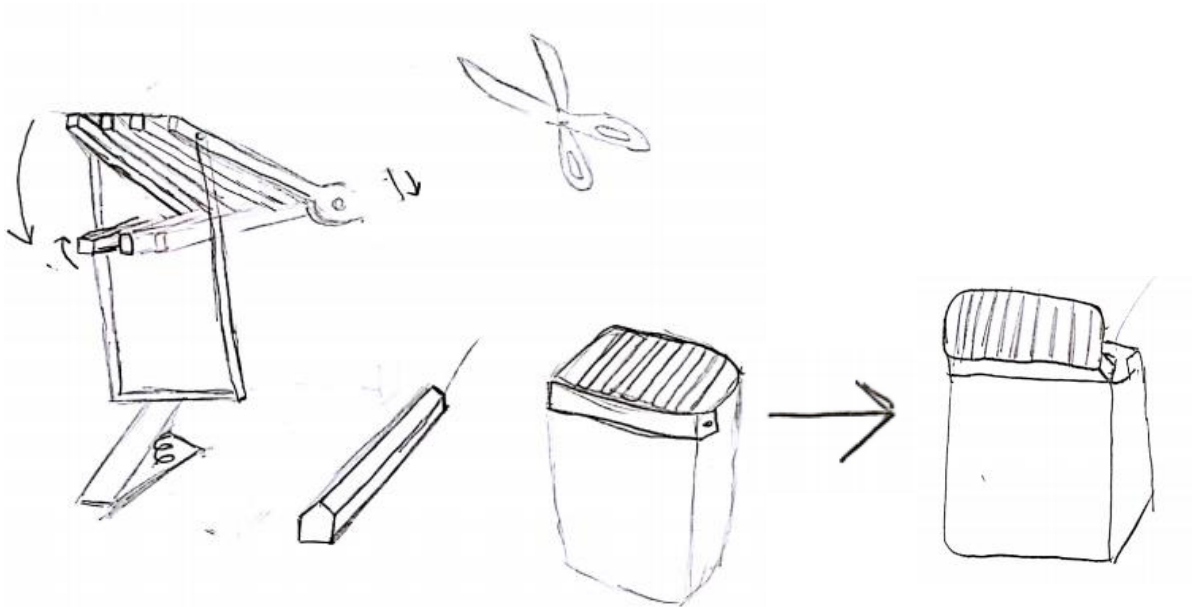

This design derives from a simple scissor-shear design. The shear mechanism is attached to a foot-pedal that brings that top half of the system down, essentially cutting the paper into strips like multiple scissors would. When the foot-pedal is let go, the top row half of the system comes back up for more paper to be placed. The system is designed to fit on top of a bin, while the mechanism attached to the foot-pedal rests along the inside wall of the bin. The system would be locked onto the top of the bin, but when it is time to empty, it would need to be unlocked by using a latch. On the other side of the mechanism would be attached to a hinge, so the system could be lifted from one side and be emptied out, or a trash bag could be lifted from the bin and easily replaced.

Design 6

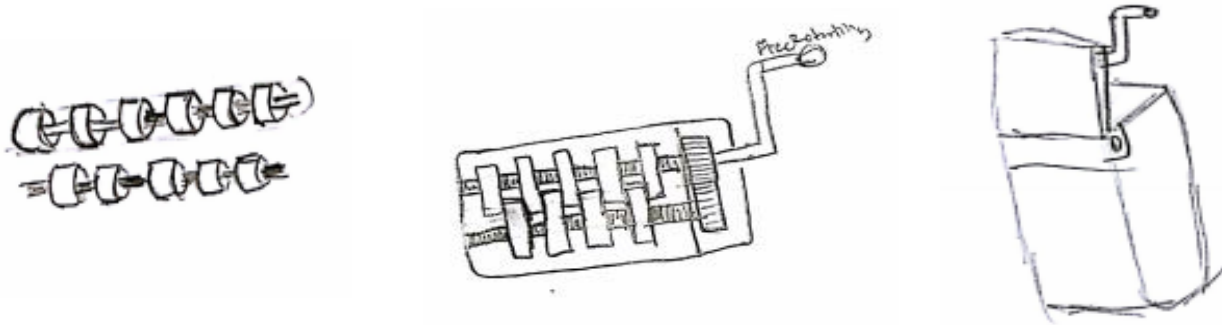

This design is inspired by the common paper shredder mechanism. There are two rows of gears that are parallel to each other and the gears align side-by-side to the parallel rows so they can shear and tear the paper. A hand-crank is attached to one row of gears that is connected to a gear that rotates the parallel row of gears. This simple gear system lets both gears rotate inwards to bring paper down to grind it, and if a jam occurs, rotating the hand-crank in an opposite direction will allow the system to reverse the paper flow and fix up jams that occur. Similar to design 5, this system will be attached to the top of a bin that is attached to a hinge on one side, and has a locking mechanism on the opposite side so the system can be opened easily to rid of waste, and easily be put back together. A trash bag can be put into the system to collect waste, and just emptied out and replaced, so the system does not need to actually be lifted.

Design 7

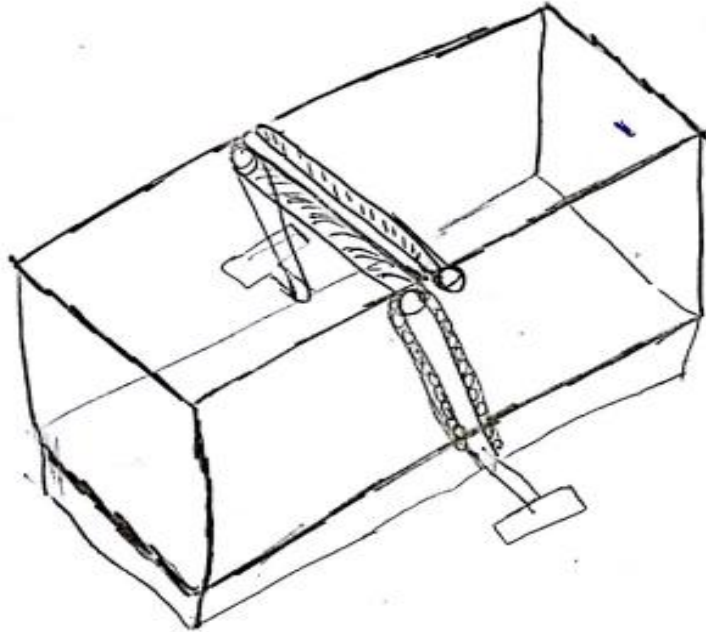

This designed is based off of a bicycle, in that it has a bike pedal on each side that you use to rotate the gears that shred the paper at the top. Each pedal is attached to a chain and gear system that convert power from the pedals to the shredding mechanism. The idea of the shredder is that it can be portable, but won't take up office room because it would be used in the commonly empty space between a person's legs while sitting in an office chair. The rectangular shape of the system allows it to fit between someone's legs while sitting in a chair and will not be uncomfortable or feeling as if it is in the way and inconvenient. The system will be composed of two rows of gears for shredding paper, attached to two gears, two chains, and finally two bike pedals for transmitting power. The paper can be disposed of with a drawer on one of the smaller faces of the system.

Design 8

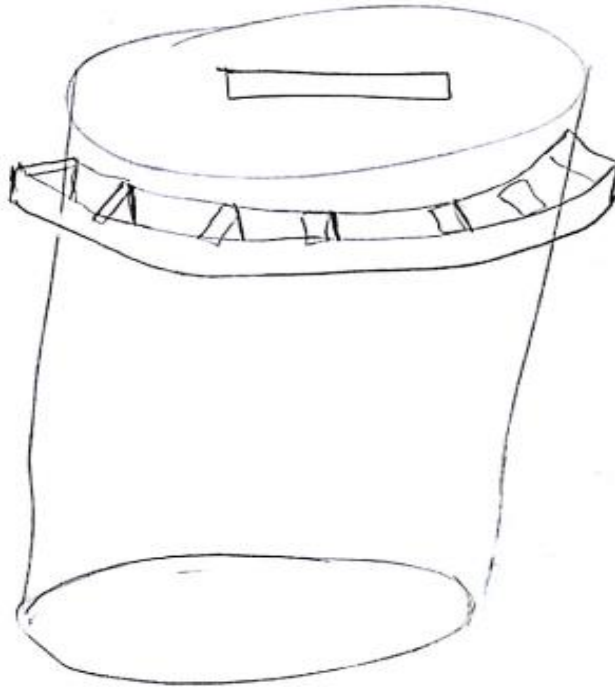

Design 8 is based off of the idea of a coffee blender. The container will be cylindrical and have the appearance of a metal trash can. A wheel will installed around the outer perimeter of the container that when rotated, will shred the paper that is inserted within it. The wheel will rotate gears inside the system that will shred and grind the paper into small pieces.

Decision Matrix Criteria

From looking at our QFD and HOQ, we found common trends in both the dimensions of our system, and the reliability of the system. We pulled criteria from our customer and engineering requirements and used those as the basis of our decision matrix. Then we used the common trends that were found to rank our criteria in an order of priority. We reached the rank and dispersed the weights in an order that we felt fitting to the priorities we arranged and managed to create the final criteria for the decision matrix, as seen in **Table 4**.

Table 4: Decision Matrix Criteria

Criteria	Weight
Reliability	15%
Cost Effective	13%
Materials (Strength of System)	13%
System Operation	11%
Volume	9%
Speed	8%
Ease of Use	7%
Stability	6%
Bin Size	5%
Shred Width	5%
Noise Level	4%
Portable	4%

We ranked reliability as the highest because we defined it as how the system operates and if it meets the requirements without maintenance. If the system cannot do its job, then we do not consider it to be a successful project overall. We ranked criteria that dealt with system operation rather high because they determine if the system works or not. Next, were the dimensions of the product, which we ranked around the middle of our criteria because we felt as long as we fit within the restrictions given to us in those areas, we would be satisfied with the system. Shred width and noise level ranked low because we are comparing those measurements to those of an electrical shredder, which we assumed to be a non-difficult task to accomplish, given that we are

designing a mechanical system with no motors. Finally, a portable design was the lowest on our criteria because we imagine this product to be used mainly within a single office space. Since, moving the mechanical system from room to room on a daily basis, is not an aspect that we are considering.

Averaged Group Decision Matrix

Each group member went home after we presented our concepts to one another and graded each concept in our decision matrix, in which we used a grading scale of 1-10. After each member finished their copy of the decision matrix, a final group average decision matrix was put together, and designs 1 and 6 were our top concepts, as seen in **Table 5**.

Table 5: Group Decision Matrix (Graded on Scale of 1-10)

Group Decision Matrix Average								
	Design 1	Design 2	Design 3	Design 4	Design 5	Design 6	Design 7	Design 8
Reliability (15%)	1.2	0.975	1.0875	1.0875	1.0125	1.1625	1.0125	1.0125
Cost Effective (13%)	0.9425	0.8775	0.8775	0.9425	1.0075	1.04	0.8775	0.91
Materials (Shredded material+10 Pages) (13%)	1.0075	0.845	0.8775	0.8125	0.845	0.975	1.04	0.715
System Operation (11%)	0.88	0.825	0.825	0.825	0.825	0.88	0.825	0.6875
Volume (9%)	0.54	0.7425	0.5625	0.54	0.72	0.6975	0.5175	0.72
Speed (8%)	0.54	0.56	0.52	0.52	0.54	0.56	0.68	0.44
Ease of Use (7%)	0.6125	0.6125	0.5775	0.5775	0.6125	0.595	0.525	0.4725
Stability (6%)	0.51	0.465	0.465	0.405	0.465	0.45	0.435	0.3
Bin Size (5%)	0.2625	0.375	0.3375	0.325	0.4	0.3875	0.325	0.4
Shred Width (5%)	0.375	0.3625	0.375	0.35	0.3375	0.3625	0.4	0.35
Noise Level (4%)	0.28	0.29	0.27	0.26	0.29	0.27	0.26	0.24
Portable (4%)	0.26	0.26	0.24	0.31	0.35	0.34	0.24	0.34
Total:	7.41	7.19	7.015	6.955	7.405	7.72	7.1375	6.5875

Common trends we found in the outcome of the decision matrix were in the reliability score, because it is the highest weighing criteria. Materials was another section where these designs excelled, and helped their total scores extend beyond the other designs. Design 5 came at a very close 3rd, which is one of the few foot pedal designs, and we will also take a look into how plausible and efficient the system can be for us, and look into it along with our main two designs.

Chosen Product

The product that we chose to retrofit is an AmazonBasics 12-Sheet Cross-Cut Paper, CD and Credit Card Shredder [4] as seen in figure 3. Compared to many competitors, this shredder meets our requirements and is also the most cost effective. The shredder comes out to \$54.99, which is more than half our budget, but the shredder blades and gearing system in the shredder are essential components to our design.



Figure 3: AmazonBasics 12-Sheet, Cross-Cut Paper, CD and Credit Card Shredder

The shredder's dimensions come out to 8.9 x 12.5 x 15.7 inches, which comes out to roughly 1.01ft³. The shredder fits within our volume limitations, which allows us to design a bigger bin size, or let our mechanism expand so we have a substantial amount of space to work with. The system comes with a 4.8 gallon bin, which is a decent space for waste storage, but we can modify this if needed.

Engineering Analysis

The group received the AmazonBasics 12-Sheet Cross-Cut Paper, CD and Credit Card Shredder and took apart the system to analyze the shredding mechanism contained within the shredder. When analyzing the system, we took note of the gear system used to operate the system, what parts could be reused, and what parts were not necessary when turning the system into a fully mechanical system, such as the motor. We used the current mechanism inside the shredder to come up with ways that we could design and retrofit the system to meet our customer requirements.

Existing Mechanism

Figure 4 is a top view of the shredder blades and mechanism that is within our system. The gear at the top marked with the blue arrow was originally connected to the motor of the system by a gear train, yet it will be used as the input gear for our retrofitted system. The gear rotates both clockwise and counterclockwise, and this dictates the rotation of the shaft perpendicular to it. The shaft has a 1-1 gear ratio with the parallel shaft on the sides, which rotates the other shaft at the same time, in the opposite direction. This shaft will be our main focus when retrofitting system because it is connected directly to the cd shredder attached to the side as well

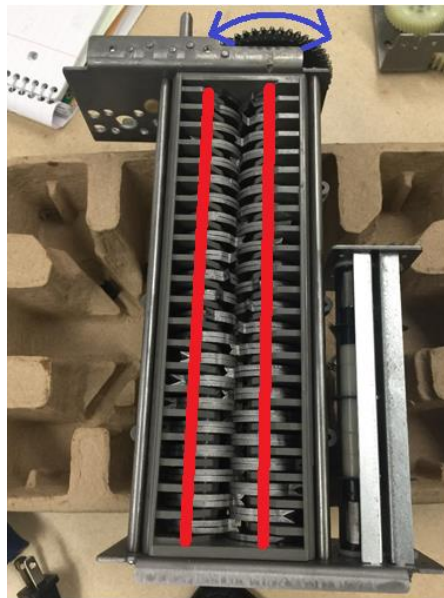

Figure 4: Top View of Shredding Mechanism

Figure 5 shows the face of the mechanical system that we will focus on retrofitting. The gear on the left is the gear connected to the main shaft mentioned in Figure 4. This is a better showing of the 1-1 ratio of the gears to provide the equal rotation.



Figure 5: Main Gear Face to Retrofit

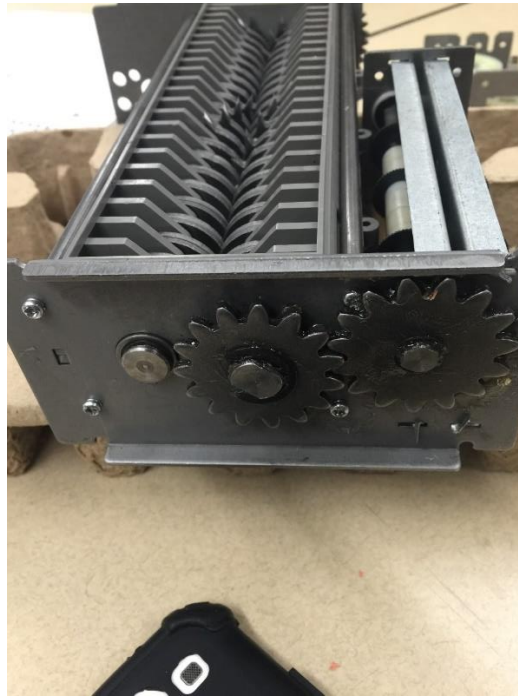

Figure 6: Main Shaft Gear System to CD Shredder

Figure 6 shows the opposite side of the system, that follows the shaft connected to our main gear, and how at the end of that gear is another 1-1 system that connects to the cd shredder.

Retrofit Design

The team tested the paper shredder and found out that three rotations of the shafts on the cutter blades are needed to shred a full standard sheet of computer paper. We decided to add a third gear to the system, as seen in Figure 7, that is twice the size of the original gears so the handle would only need to be rotated one and a half times to shred a full sheet of paper. The team originally wanted to go with a gear 3 times the size to require only one rotation, but the gear would not fit within the wall boundaries on the system.

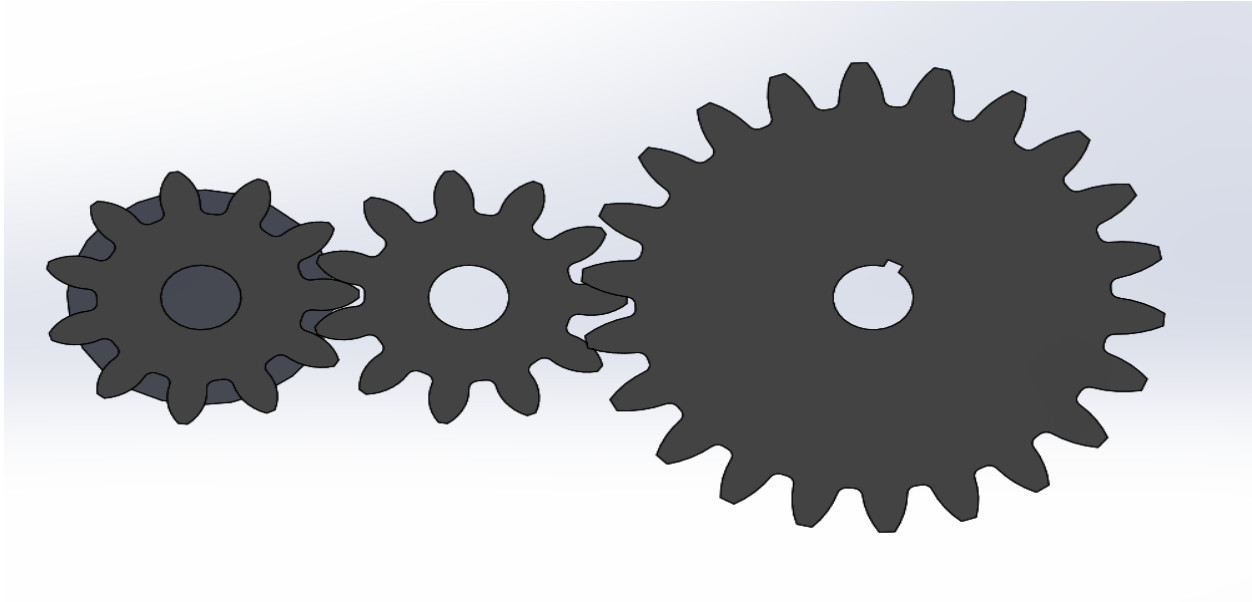

Figure 7: 2-1 Gearing Ratio System

The basic idea of our system can be seen in Figure 8, which shows our handle being implemented into the gearing system. The handle would have a rod that goes through the new gear and held in place by two sets of bearings on both sides of the gear, and a key way system with the shaft and gear. This gear train would allow us to operate the entire system without having to do too much work in rotation the handle.

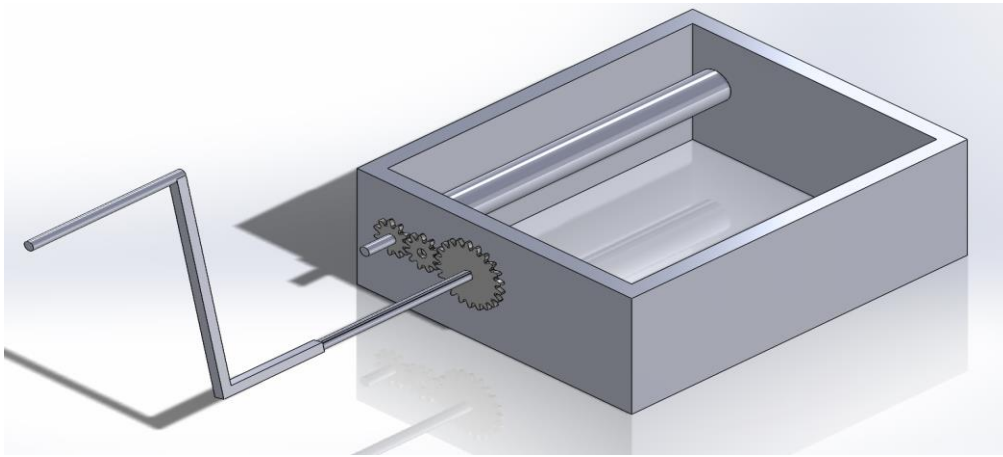

Figure 8: Retrofit System with Hand Crank

After a discussion with our client, we were informed that 3 rotations was not a negative aspect and felt like a reasonable amount of rotations to shred a length of paper. With this new information, the team decided on the possibility of designing a shaft to be connected directly to

the shaft of the main gear that comes with the system. This allows us to ignore the need of a new custom gear, and having to tamper with the faceplate that the gears are currently on. This creates a simpler system, and will also end up costing us less money from our budget to retrofit the system, at the cost of having to do a small amount of more work in rotating the handle to shred the paper.

List of Parts and Prices

Table 6: Bill of Materials

Parts	Price
AmazonBasics 12-Sheet Cross-Cut Paper, CD, and Credit Card Shredder	\$54.99
Steel Ball Bearings	~\$6.00 each*
Steel Spur Gear	~\$25.00**
1 Aluminum Crank Handle	~\$20.00*
1 3/8" Diameter Hardened Shaft	\$4.45
	Total: \$116.44

Table 6 shows the prices that manufacturing would cost if we decide to include a custom gear and make a compatible shaft and crank handle. This table can be seen as the worst case scenario with the maximum manipulation of the system needed, and this will put us over budget by \$16.66. All prices are estimated from McMaster[5].

Conclusion

The team's objective this semester was to develop a design for a mechanical paper shredder that met the customer requirements, and operated at, at least half of the efficiency of an electric paper shredder. An HOQ and QFD were developed to find common trends in our customer requirements and qualities of a mechanical paper shredder. A Gantt Chart was created to give this semester a schedule to our design process.

After we developed an idea of what we wanted from the paper shredder, we went into our design concept phase. Each team member brainstormed 2 different designs that we wanted to see for our paper shredder. We gathered information from the HOQ and QFD to develop a decision matrix to grade each members design concepts. The team created an averaged decision matrix with each member's scores to find which designs were more favorable. We ended up with a simple hand crank design in both final ideas, and we decided this is where we would go with the project.

Going into the engineering analysis phase we found that we could not properly create the paper shredder teeth on our own and were given the permission to buy an electric paper shredder online to retrofit into a fully mechanical system. We received our paper shredder and did a simple analysis on how the gear system functioned and found out that we could retrofit the system to have an extra gear connected to a crank to operate the entire system. The team was also given permission to attach a crank to the main gear in the mechanism.

The team will now go into next semester with a design of a hand crank to attach to the main shaft of the system and work on designing a casing and shell for the mechanism. Furthermore, we will add the proper features so the system can be emptied properly, mounted onto a wall, and stand alone on its own.

References

- [1] Science Club. *How Many Watts of Electricity does a Paper Shredder Use* [Online]. Available: http://www.cockeyed.com/science/power_use_database/paper_shredder.html
- [2] Amazon. *Paper Shredder* [Online]. Available: <http://www.amazon.com/The-Premium-connection-290-SHRED-Shredder/dp/b006J99PQQ>
- [3] Better Living Through Design. *Manual Paper Shredder* [Online]. Available: <http://www.betterlivingthroughdesign.com/accessories/manual-paper-shredder/>
- [4] Amazon. *Amazon Basics 12 Sheet Cross Cut Credit Shredder* [Online]. Available: <http://www.amazon.com/AmazonBasics-12-Sheet-Cross-Cut-Credit-Shredder/dp/B005QAQFFS>
- [5] McMaster. *McMaster-Carr* [Online]. Available: <http://www.mcmaster.com>