

# Mechanical Shredder

By

Ryon Baloo, Kendall Meyer, Mohammed Molani,  
and Sultan Alshahrani

Team 10

## Engineering Analysis

Document

*Submitted towards partial fulfillment of the requirements for  
Mechanical Engineering Design I – Fall 2014*



Department of Mechanical Engineering  
Northern Arizona University  
Flagstaff, AZ 86011

## Table of Contents

Analysis Introduction.....	2
Customer Needs Review .....	2
Chosen Product .....	3
Existing Mechanism.....	4
Mechanism Design.....	5
List of Parts and Prices .....	6
Conclusion .....	7
References.....	8

## Analysis Introduction

Upon the team's two concept selection, we continued to perform an analysis on the validity of the mechanical paper shredder. A potential gearing system was developed to substitute for the electric circuit system. After researching the market for an electric paper shredder to retro fit and combine with our gearing system, we selected the AmazonBasics 12-Sheet Cross-Cut Paper, CD, and Credit Card Shredder from Amazon.com. With this product, we will take apart the compartment to obtain the teeth shredder/gear system in order to determine how we will convert it all into a mechanical system.

At this time, the team is deciding to use the shaft, teeth shredder, and gears of the AmazonBasics system. We will use these components to finalize our own dimensions of our mechanical gearing box which we previously designed in SolidWorks. Additional cost were estimated for other system components we may need to fully define our mechanical system. However, the team is currently waiting on the package to arrive to fully decide on what we need from the AmazonBasics system.

## Customer Needs Review

Our initial customer needs required the team to design a completely mechanical, portable, environmentally friendly paper shredder that can compete with an electric paper shredder that is found on the market. The group is limited to a budget of \$100 for fabrication and has to fit within a 5ft<sup>3</sup> volume. The paper shredder has to also meet certain specifications, such as: shredding 10 sheets of paper per feed, 36 pages per minute, and be able to shred paper, CD's and credit cards.

After our design concepts were decided through a group decision matrix, we added additional customer needs. Our system additionally needs to be retrofitted from an electronic paper shredder that we could find locally or online. The shredder also has to have the option of being wall-mounted, or be able to stand on its own and this is up to customer preference. A handle will be retrofitted to the system to operate the shredding mechanism, and the handle will preferably be on the front face of the shredder, so as to not be interfered with by the wall during rotation of the lever.

## Chosen Product

The product that we chose to retrofit is an AmazonBasics 12-Sheet Cross-Cut Paper, CD and Credit Card Shredder as seen in Figure 1. Compared to many competitors, this shredder meets our requirements and is also the most cost effective. The shredder comes out to \$54.99, which is more than half our budget, but the shredder blades and gearing system in the shredder are essential components to our design.



Figure 1: AmazonBasics Paper Shredder [1]

The shredder's dimensions come out to 8.9 x 12.5 x 15.7 inches, which comes out to roughly 1.01ft<sup>3</sup>. The shredder fits within our volume limitations, which allows us to design a bigger bin size, or let our mechanism expand so we have a substantial amount of space to work with. The system comes with a 4.8 gallon bin, which is a decent space for waste storage, but we can modify this if needed.

## Existing Mechanism

There is no patent for the AmazonBasics paper shredder online. The team had to assume on what the electric system looked like by combing two different company patents that were found on the internet. The electronic design consist of two shafts that are covered with teeth shredders. The shafts are fixed on the side of the plastic container where it could rotate freely. The electric mechanism is being powered by battery and a power supply and also has a control system to shred paper (Figure 2).

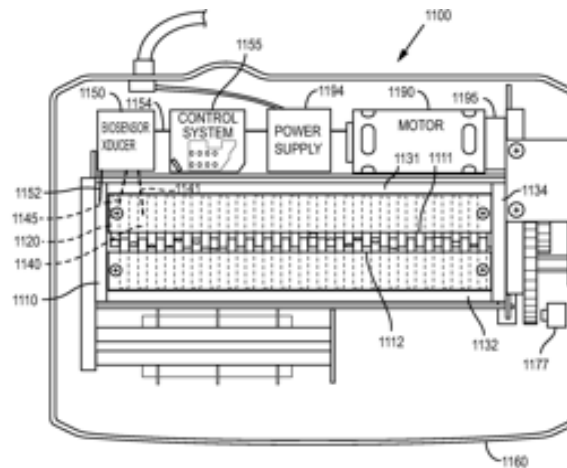

Figure 2: Typical Electric Shredder Configuration [2]

Each teeth on the rotating shaft is separated by plastic spacers and are at an offset angle that prevents the teeth from interlocking with one another. The shaft in Figure 3 looks as if the teeth are fixed to it so we are going use its system and create a new gear box to fit its dimensions. The design of the teeth looks complicated because the team is limited to design tools here on campus. This is the reason why we are considering using the whole shaft along with the teeth design.

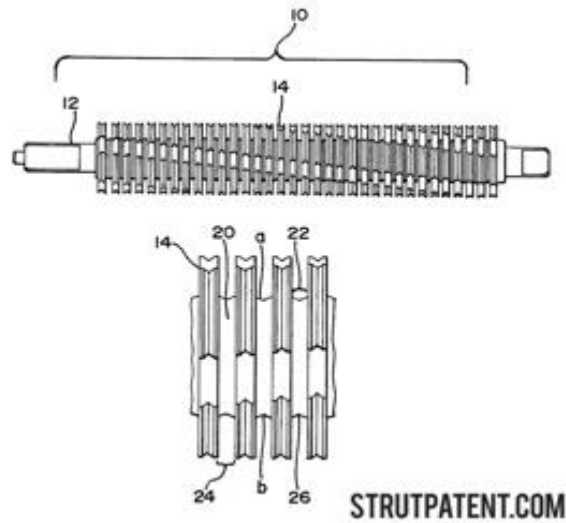

Figure 3: Cutter Blade Schematics [3]

Basically, we are using the shaft along with the teeth for our mechanical design because the gear in Figure 1 looks nondurable. Additionally, this will help us incorporate other parts that are essential for our mechanism design.

## Mechanism Design

Our design consist of two perpendicular bevel gears, where one is attached to a shaft the will be rotated by a hand crank. The bevel gears will be able to turn one spur gear that is attached on the same shaft of the perpendicular bevel gear. Once the first spur gear is rotated, it will rotate the other spur gear in opposite rotation shown in Figure 4. This will allow our design to shred the paper with a proper amount of human torque.

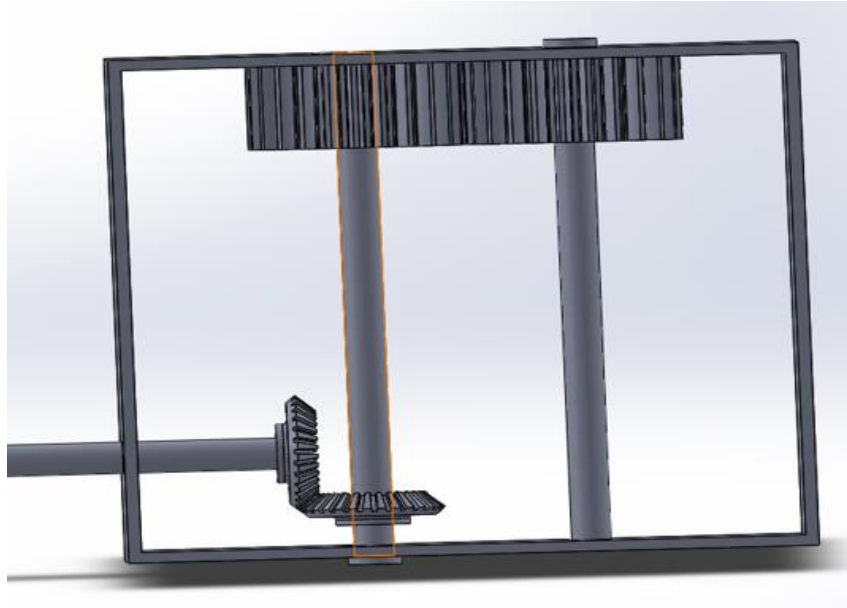

Figure 4: Our Simple Gearbox Design

This gear design requires five steel ball bearings that will be inserted on the shaft ends with the spur gears and the shaft that runs through the gear box to the hand crank. In other words, this will help prevent friction that will occur in between the shaft and the gear box hole. Furthermore, this system was dimensioned by using the electronic paper shredders located in stores in Flagstaff, AZ as a guide.

## List of Parts and Prices

Table 1: List of Parts and Corresponding Prices

Parts	Price
AmazonBasics 12-Sheet Cross-Cut Paper, CD, and Credit Card Shredder	\$54.99
5 Steel Ball Bearings	~\$6.00 each*
2 Molded Nylon Plain Bore Bevel Gears	~\$4.00 each*
2 Molded Nylon Plain Bore Spur Gears	~\$10.00 each*
1 Aluminum Crank Handle	~\$20.00*
1 3/8" Diameter Hardened Shaft	\$4.45
	Total: \$137.44

Table 1 above shows the estimated budget to retrofit the mechanism of our paper shredder. The prices are estimated from McMaster.com [4] since we don't know what will be contained within the AmazonBasics paper shredder. We are initially going with nylon plain bore bevel and spur gears, because they are the proper size for what we assume the shaft diameter might be for the cutter blades. If we decided on aluminum or steel gears, the budget for the gears would double and put us way over our budget. If need be it is possible to create our own handle for the system. But if that cannot be done within the machine shop, we can purchase an aluminum crank with a free rotating handle, and an aluminum shaft to connect the handle to the inside bevel gear.

Our budget does go over our limit by \$37.44, but this is with estimates and not knowing what is contained within the paper shredder we are buying. We believe that we will have more useful parts when we can properly open up the shredder and disassemble the parts. Hopefully, this will deeply cut down on the budget if we can use parts in the machine for other purposes.

## Conclusion

For this project, we are designing a mechanical shredder, which meets customer requirements. The customer required a mechanical shredder, 5 ft<sup>3</sup> bin, shreds up to 10 papers, CD's, and credit cards. In addition, it also required a maximum budget of \$100 and had the capability of being mounted on a wall. After the design analysis, the team agreed on a simple gear/crank design. We would customize the electrical shredder to work as a mechanical system which will save time and money. The AmazonBasics 12-Sheet Cross-Cut Paper was our best choice, ultimately due to its price and design. Furthermore it will meet all requirements after we extract parts in order to customize it. The mechanism part will cost about \$83.00 and the shredder will cost us \$54.99. Consequently, it will put us over budget by \$37.44, yet it was the best overall design meeting all of the requirements.



## References

- [1] Amazon. *Amazon Basics 12 Sheet Cross Cut Credit Shredder* [Online]. Available: <http://www.amazon.com/AmazonBasics-12-Sheet-Cross-Cut-Credit-Shredder/dp/B005QAQFFS>
- [2] Bruce R. Kroger and Raymond R. Ferriss, “Paper Shredder Shaft” U.S. Patent 0626078, Aug 26, 1999. [Online]. Available: <http://www.strutpatent.com/patent/06260780/paper-shredder-shaft>
- [3] Kevin Chen, Chung Shih Tsai, Hsin-hsiung Chen, “Paper Shredder Control System Responsive to Touch-Sensitive Element” U.S. Patent 8008812 B2, Aug 30, 2011. [Online]. Available: <http://www.google.com/patents/US8008812>
- [4] McMaster. *McMaster-Carr* [Online]. Available: <http://www.mcmaster.com>