

# Ultra Low Cost Solar Water Heater

By  
Austin Chott, Chris Heine, Matt Beckham, Saleh Alsadiq,  
Thomas Griffin  
Team 13

## Progress Report 1 Document

*Submitted towards partial fulfillment of the requirements for  
Mechanical Engineering Design I – Fall 2013*



Department of Mechanical Engineering  
Northern Arizona University  
Flagstaff, AZ 86011

# 1. Introduction

## 1.1 Client's Point of View

In the United States, a high startup cost combined with a lack of knowledge about solar water heaters has contributed to low usage. Solar water heaters are a viable way of reducing energy consumption as well as reducing a household's carbon footprint. Solar energy is abundant and free which makes it the best option for a low cost energy source. Many factors must be considered when looking to reduce cost and improve or maintain efficiency of solar water heaters.

The U.S. Environmental Protection Agency (EPA) wants to change how solar water heaters are perceived which drove them to fund the project through the P3 – People, Prosperity, and the Planet Award Program. This program gives students the opportunity to research, develop, and design solutions to real world problems involving the sustainability of society as a whole. This program was developed in order to meet the technical needs of society in relation to a sustainable future. The following document contains all the information that has been gathered thus far and provides a final proposal solution to the overall problem.

## 1.2 Problem Statement

Current solar water heaters are too expensive and it takes a long period of use to make them financially sensible. Therefore, current solar water heater designs are financially impractical over a short period of use.

The solution to this need is to design a low cost solar water heater that is efficient enough to produce a quick financial return.

## 1.3 Objectives and Constraints

Below is a list of all the objectives and constraints. Our main operating environment will be outdoors and this will be reflected throughout all the descriptions.

- Heats Water: The objective of this project is to create a low cost solar water heater that heats water by solar convection.
  - Constraint: Potable Fluid Temperature (°C): This solar water heater will maintain a specified temperature throughout a 24hr period.
- Weather Proof Design: The solar water heater must be weather proof since water heaters will typically be outside, either in a yard or mounted on a roof.
  - Constraint: Durability (Pa & Km/hr): The solar water heaters must be able to withstand high wind speeds; impact forces from hail, rain and debris; and in some cases, pressures from snow.
- Low Initial Cost: One significant problem with solar water heaters currently in the market is the initial cost of the heater is too expensive, and therefore requires the need of long-term use before there is a financial return.

- Constraint: Break-Even Cost (USD): Things that influence the initial cost of the solar water heater are: materials used, complexity of the design, quantity of materials used, difficulty of manufacture and difficulty of production. As any of these cost multipliers increase, initial cost will increase.
- Low Maintenance Cost: The cost of maintenance should also be low to optimize break-even cost.
  - Constraint: Routine Maintenance Cost/Frequency (USD/Years): Frequency of maintenance should be at reasonable intervals varying slightly between geographical regions as well as daily use.
- Quick Financial Return: A solar water heater must show positive capital quickly in order for it to appeal to the general public.
  - Constraint: Break-Even Cost (Years): The solar water heater must conserve energy while maintaining a satisfactory working temperature of the potable fluid. Sacrifices in efficiency must be balanced with initial cost to obtain a quick financial return.
- Implemented into Current Water Heating Systems: A high percentage of houses in the world have an existing water heating system currently installed. Many systems which use solar heat also use gas or electricity for times when solar energy is not available.
  - Constraint: Able to be integrated into Current Systems (yes/no): To maintain marketability and appeal it is crucial for the solar water heater to be easily integrated into current water heating systems. The ease of installation will be measured with a yes/no metric based on surveyed data.
- Safe Operation: Operating the solar water heater should be safe under all condition.
  - Constraint: Safety (yes/no & °C): Safety and energy conservation are factors to be considered when selecting the water temperature setting of a water heater. High water temperatures can cause severe burns or death from scalding. The solar water heater design should meet all government safety standards and regulations.
- Sensible System Size: A properly sized water heater system will provide a significant portion of a home's hot water.
  - Constraint: Size (m<sup>3</sup>): A water heater should be easily contained inside a house or apartment. The system size should not be a restraining factor.

Table 1: Objectives and Constraints

Objective	Constraint	Units
Heats Water	Potable Fluid Temperature	degrees C
Weather Proof	Durability	Pa
Low Initial Cost	Break Even Cost	USD
Low Maintenance Cost	Maintenance Cost	USD
Quick Financial Return	Break Even Cost	Years
Implementation	Able to be Integrated	yes/no
Safe Operation	Safety	yes/no
Sensible System Size	Size	m <sup>3</sup>

### 1.5 State of the Art Research

Based on prior research it was found that current solar water heaters in the US cost 5,000 to 10,000 USD which presents the problem and our needs for our team. Our analysis considers this high price for a commercial solar water heater sold in the US and reduces the cost by using parts found from local hardware stores that are significantly cheaper. Our research shows that there is also the possibility of scavenging our systems parts because it has been done in other cheap solar water heater designs and because most parts of our system can be found in construction scrap piles.

## **2. Original Concepts for Consideration**

The main specification evaluated in this section while determining possible solutions was absorption per cost per area. Designs that did not show promise of optimal absorption per cost per area were discarded. Multiple concepts are considered for this project. Collector and circulations systems are the main aspects in the solar heater. Several options for both systems are briefly described in this section.

### 2.1 Collector Systems

#### 2.1.1 Involute Curve Solar Collector

An parabolic solar water heater consists of a system of one or more stationary parabolic collectors focused on a cylindrical absorber as shown in Figure 1. The parabolic curve allows for nearly all the radiation energy from the sun to be directed to the absorber and subsequently absorbed and transferred to the fluid. Through the geometry of the parabolic curve the solar rays will bounce off the reflectors any number of times always being directed to the absorber. A study done by Smyth in 1989 showed that parabolic solar water heaters retained 60% of the collected solar energy for a 16 hour non-solar period.

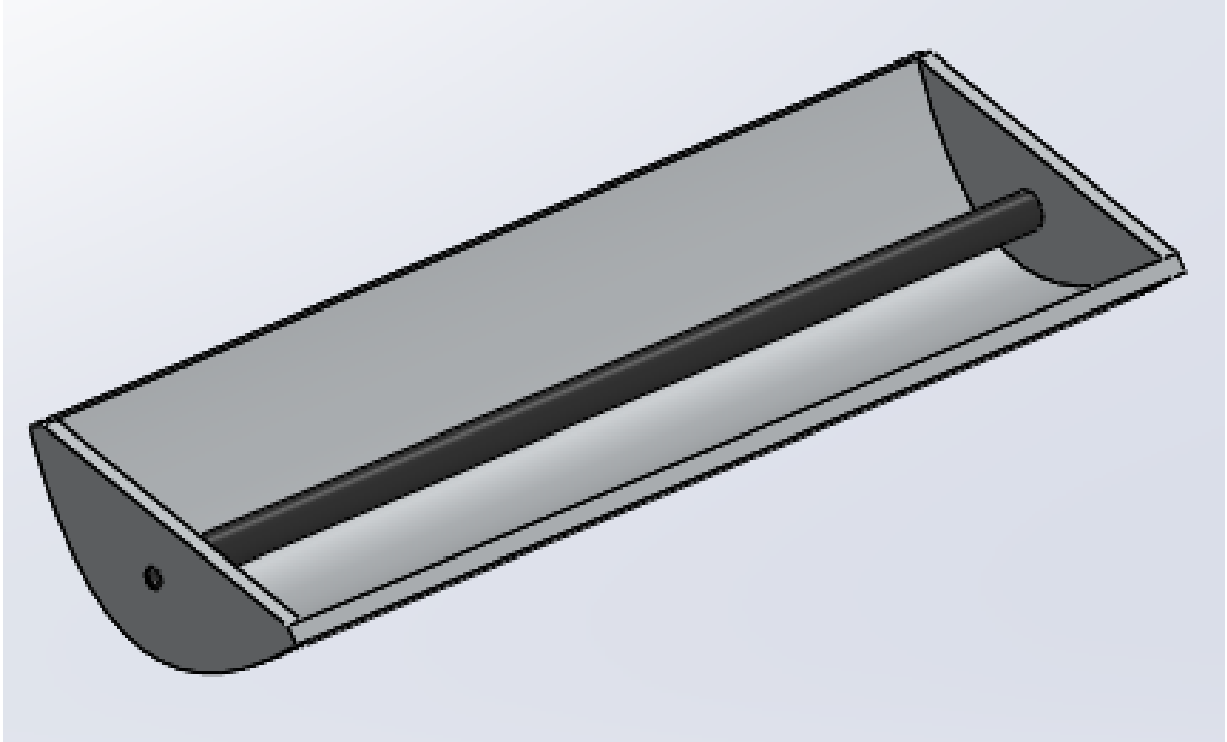

Figure 1: Parabolic Curve Collector

- Variations of this design include: a system of multiple absorber tubes housed in parabolic crescents and double parabolic curves with an absorber placed in the center.. Figures 2 and 3 below show diagrams of the various designs.

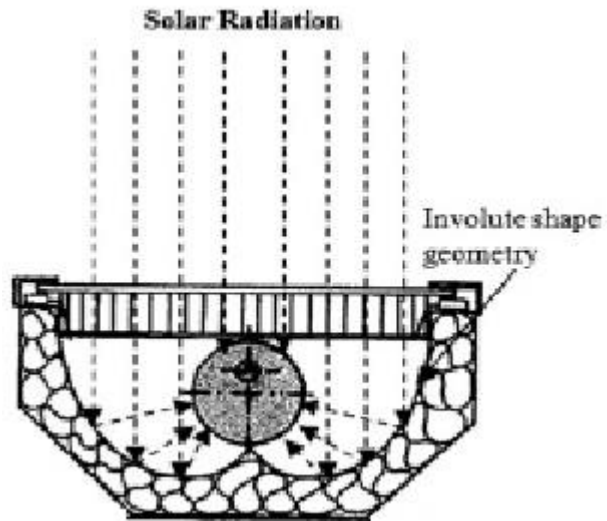

Figure 2: Tank Centered Between Two parabolic Curves

- The parabolic solar water collector paired with a passive circulation system provides a very high absorption per cost per area ratio. The biggest benefit of passive circulation is the high ratio of absorption per cost.

### 2.1.3 Breadbox Solar Water Heater Utilizing Active Circulation

The bread box solar water heater design utilizes a large frontal area of capture so that a large amount of solar radiation can be absorbed and stored. The basic concept is that a stripped black tank is mounted inside some kind of box and tilted towards the sun. A piece of dual pane glass is placed on top of the box so that the solar radiation can move into the box with the tank, but it cannot escape. The goal is to trap as much heat inside the box as possible without letting any of that heat out. This trapped heat moves through the tank and into the tank where the water is stored. Angled light reflectors will be connected to three of the four sides to direct as much light as possible into the area where the tank of water sits.

The main advantage of this design is its simplicity and the ability to store and heat water at the same time. The bread box design is something that almost anyone can build and utilize with simple knowledge and materials. This simplicity allows for a low initial cost of building but it may not be as efficient as some of the other proposed designs. The other advantage is the ability to heat and circulate water in the same vessel. There is no need for a storage tank to keep the water warm. This helps the user because he or she can just take from the hot water supply as needed. This advantage greatly reduces overall cost compared to the other proposed systems. If the cost of materials can be severely minimized and the efficiency can get to a moderate level, than the bread box design shows the most promise for a final concept.

The bread box design must utilize an active system of circulation. Although the active system is less cost effective, this concept can use the pressure provided by the city to pump the cold water to the home. This lowers cost because the user doesn't have use an outside pump to move the water through the system. The water is going to move as fast as the pressure the city provides moves it. This allows for the cold water to be heated up longer because it is going to sit in the tank a little longer than if you pump the water in and out of the tank. Below is a simple graphic of the structure of a bread box designed solar water heater.

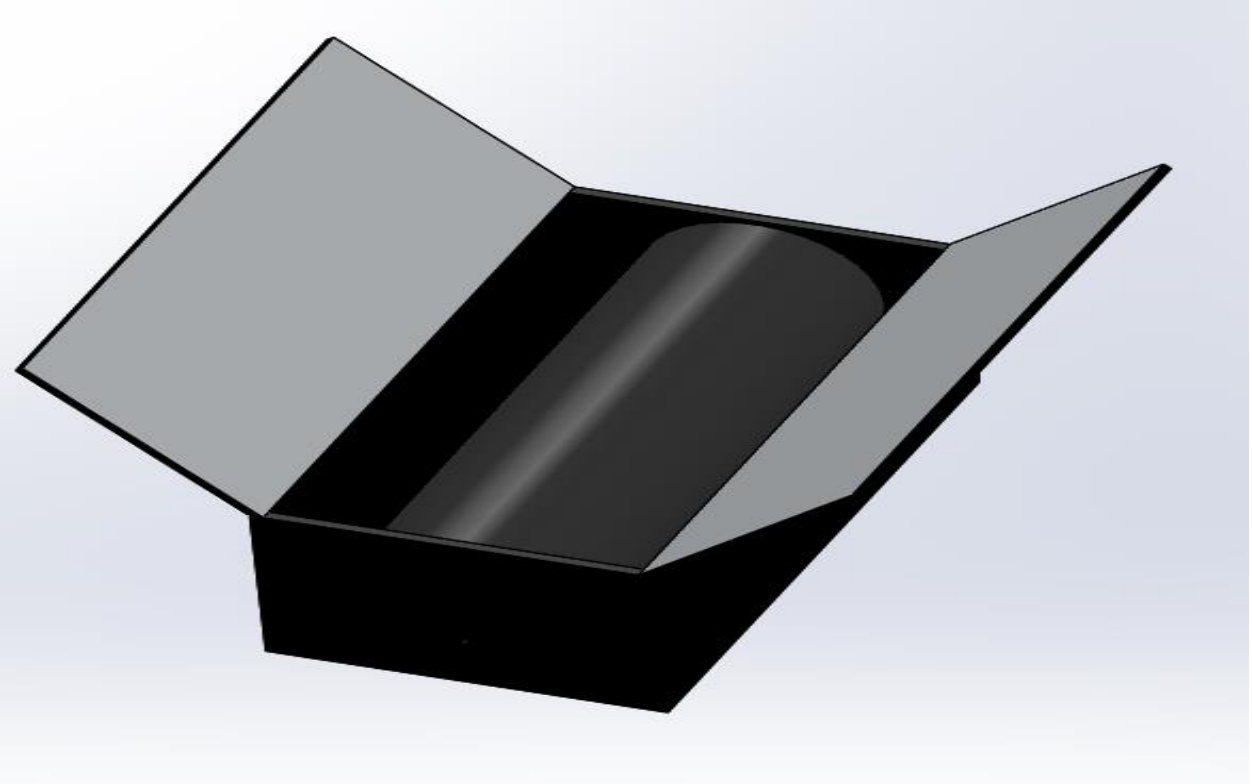

Figure 5: Bread Box Solar Water Heater

## 2.2 Implementation and Circulation

Our SWH will be integrated through the cold water inlet to an existing water heater. There will be a simple valve system shown in Figure 6 which will allow the homeowner or tenant to shut off water flow to the SWH and use the existing water directly from the source. It will require two T joints to be installed directly above the cold water inlet to the existing water heater. The pre-heated water from the solar water heater will return back to the original inlet allowing the existing water heater to function as originally intended.

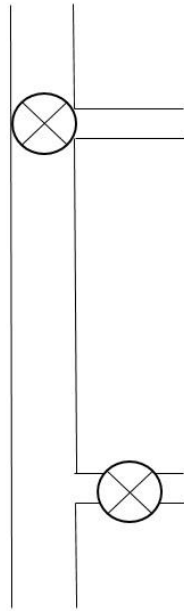

Figure 6: Integration schematic

### 2.2.1 Active Circulation System

In the active system concept, water is drawn from the original source and fed into a secondary storage tank. From there, a pump draws the water out of the tank and feeds it to the collector at an efficient rate. The water is heated in the collector and flows back into the tank. This process gradually raises the average temperature of the tank. When the existing water heater draws water, it is taken from this tank. It is important to note that a pressure release valve must be placed in the secondary storage tank to avoid a dangerous buildup of gasses.

#### 2.2.1.1 Advantages and Disadvantages

There are several advantages to using an active circulation system. First, an active system allows more freedom in implementation. This system makes the position of the collector irrelevant to the position of the secondary storage tank. Second, this system may yield much higher system efficiencies by allowing much more control of the flow rate of fluid through the collector. Third, this system can much more easily control when, and how much, water is drawn from the SWH.

There are also some disadvantages to this type of system, most importantly, being its cost. This type of system requires a possibly expensive secondary pump to be installed within the SWH system. Also, it is much more difficult to build and maintain, especially for the average homeowner.



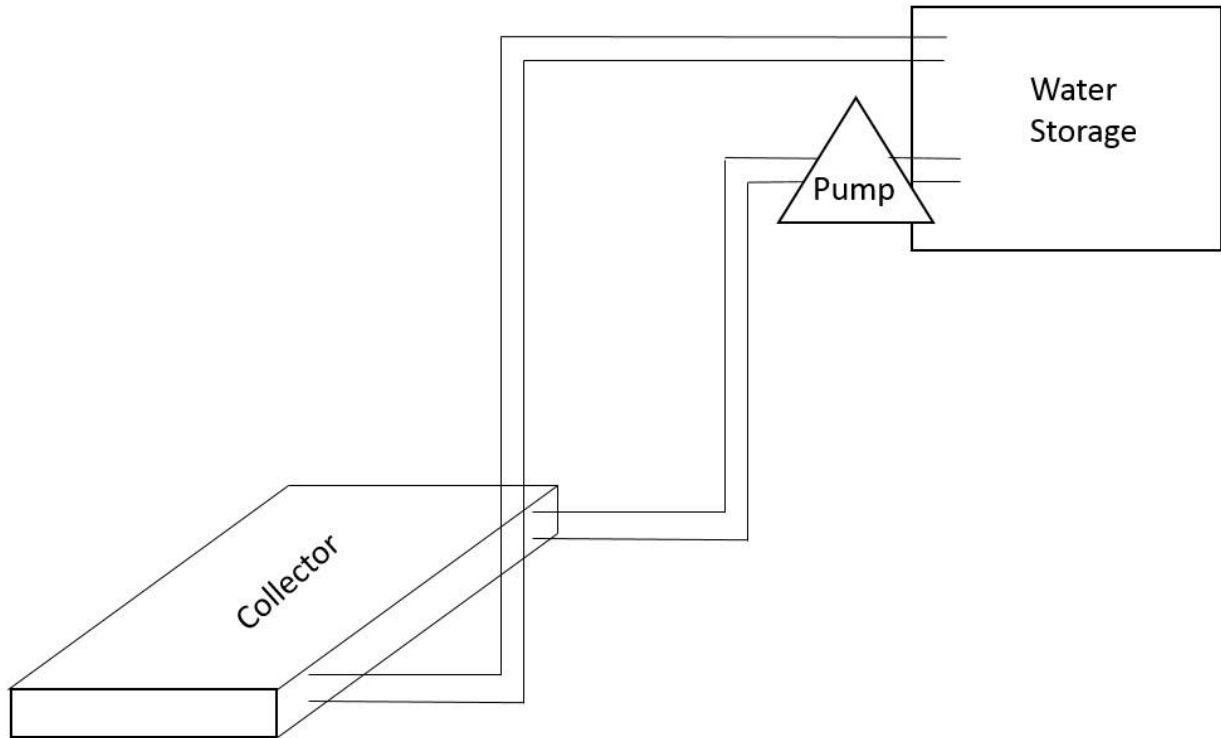

Figure 7: Active circulation system

### 2.2.2 Passive Circulation

In the passive system concept, water is drawn from the original source and fed into a secondary storage tank. The entire system must be filled for flow to start. This system relies entirely on a thermosyphon to move water through the collector. The collector must be placed below the storage tank in order for the thermosyphon to work. When water is heated in the collector, the resulting pressure difference causes it to rise and flow into the storage tank. A one way valve is placed near the collector to ensure the flow continues to circulate. This process gradually raises the average temperature of the tank. When the existing water heater draws water, it is taken from this tank. It is important to note that a pressure release valve must be placed in the secondary storage tank to avoid a dangerous buildup of gasses.

#### 2.2.2.1 Advantages and Disadvantages

A thermosyphon circulation system is much cheaper than an active system. This is because it does not require a secondary pump. However, the circulation is entirely dependent on solar energy. This means two things. First, without maximum solar radiation on the collector, possible on a cloudy day, the circulation is severely hindered. Second, this means that the efficiency of the SWH will be notably less than a SWH with an active system.

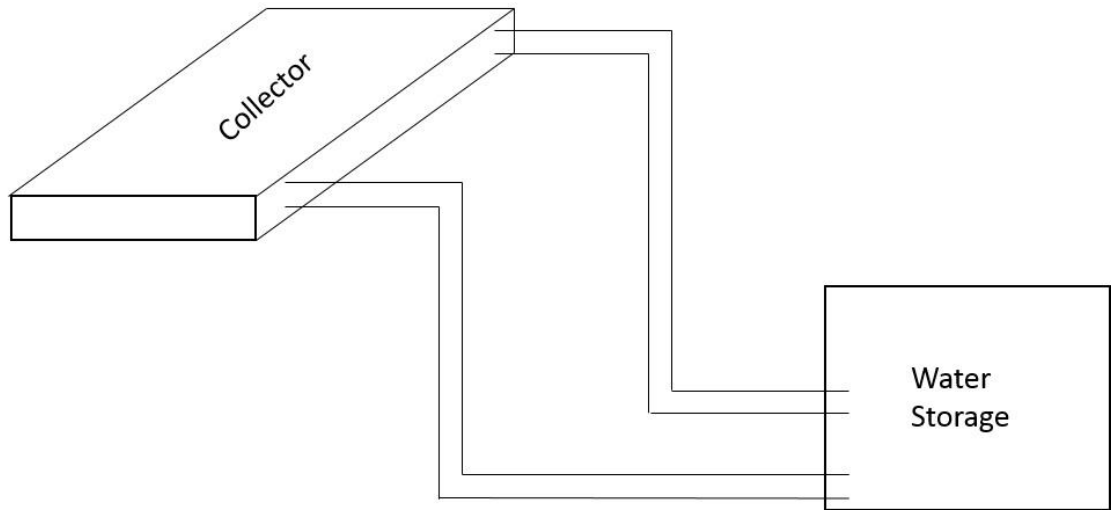

Figure 8: Passive circulation system

### 2.2.3 Bread Box Circulation System

The bread box collector system requires a unique, but simple, circulation system. The flow through this system is entirely dependent on the rate at which the existing water heater uses water. This is because the secondary storage tank in this SWH is also the collector. It is connected so that water flows freely through the collector at the same rate it is used in the existing water heater.

### **3. Decision Matrix**

The decision Matrix below shows the different concepts chosen and their evaluating objectives. The main aspects of our decision matrix are absorption, area and cost. Three collector with different circulation systems options are included in the matrix. One through nine ranking scale is used to get the heights rank.

	Weight	Involute (Active)	Involute (passive)	Parabolic (Active)	Parabolic (passive)	Flat plate (open /active)	Flat plate (closed /active)	Flat plate (open /passive)	Flat plate (closed /passive)	Bread Box
Absorbtion	9	9	9	3	3	3	9	3	3	9
Area	9	9	9	9	9	3	3	3	3	3
Cost	9	3	3	3	3	1	1	9	3	3
Buildable	5	1	1	3	3	9	3	9	3	9
System Size	3	9	9	9	9	3	3	3	3	1
	Raw	221	221	177	177	117	141	189	105	183
	Rank	1	1	5	5	8	7	3	9	4

## 4. Results

### 4.1 Area/\$

#### 4.1.1 Bread box collector and circulation system

- With an area of 4.6 m<sup>2</sup> and a cost of \$201.82 the area per cost of the bread box collector with plastic covering is .02256, giving it the highest area per cost value out of all of the other collector designs.
- With an area of 4.6 m<sup>2</sup> and a cost of \$279.80 the area per cost of the bread box collector with glass covering is .01627.

#### 4.1.2 Parabolic collector and circulation system

- Using an area of 1.16 m<sup>2</sup> and a cost of \$255.64 the area per cost of the parabolic collector with galvanized, unpainted piping is .01194.
- Using an area of 1.16 m<sup>2</sup> and a cost of \$260.23 the area per cost of the parabolic collector with galvanized, black painted piping is .01140.

#### 4.1.3 Flat plate collector and circulation system:

- With an area of .93 m<sup>2</sup> and a cost of \$488.42 the area per cost of the flat plate collector with galvanized pipe with no spacing in between each pipe is .00282, giving is the lowest area per cost value out of all the other collector designs.
- With an area of .93 m<sup>2</sup> and a cost of \$234.9 the area per cost of the flat plate collector with a rock bed as a thermal reservoir is .01214.

### 4.2 Area/\$ conclusion:

It is obvious from this analysis that the bread box collector and circulation system utilizing a plastic cover is the most affordable per its area.

#### 4.3 Absorption/area/\$

##### 4.3.1 Bread box collector and circulation system

- With an absorption of 654.32 W for plastic covering, an area of 1.67 m<sup>2</sup>, and a cost of \$181.31 the absorption per area per cost is 2.16.
- With an absorption of 776.6 W for glass covering, an area of 1.67 m<sup>2</sup>, and a cost of \$201.36 the absorption per area per cost is 2.31.

##### 4.3.2 Parabolic collector and circulation system

- Using an absorption of 514.07 W for galvanized, unpainted piping, an area of 1.16 m<sup>2</sup>, and a cost of \$255.64 the absorption per area per cost is 1.73.
- Using an absorption of 737.04 W for galvanized, black painted piping, an area of 1.16 m<sup>2</sup>, and a cost of \$260.23 the absorption per area per cost is 2.44.

##### 4.3.3 Flat plate collector and circulation system:

- Using an absorption of 738.48 W for galvanized pipes with no spacing, an area of .93 m<sup>2</sup>, and a cost of \$488.41 the absorption per area per cost is 1.63.

#### 4.4 Absorption/area/\$ conclusion

It is obvious from this analysis that the parabolic collector and circulation system utilizing galvanized, black painted pipe is the most affordable per its absorption per area and will be the design that team 13 will use as a final concept.

### **5. Cost analysis**

The cost of each considered design is analyzed based on three categories: each part purchased, some parts scavenged, everything possible scavenged. First, the cost was analyzed based on each part being scavenged. The main application of our design is a do-it-yourself solar water heater, which the return is greater than the cost to build in less than two years. As a result the team also analyzed the cost based on what parts are reasonably scavenged, and what parts can be scavenged with considerable effort. The cost of these scavenged parts then goes to zero, significantly reducing the total cost of each design. In Tables 5-7 the blue cells indicate scavenged items for their respective categories.

#### 5.1 Parabolic Cost Analysis

Table 5: Parabolic Cost Analysis

Parabolic				
Everything Purchased				
Material	price	% used	# req	cost
Mylar sheeting 25'x50"	\$ 37.15	25%	1	\$ 9.29
Plywood 4'x8'	\$ 18.45	100%	2	\$ 36.90
flat black paint	\$ 3.00	100%	1	\$ 3.00
1" x 10' PVC	\$ 3.67	100%	1	\$ 3.67
Misc fittings	\$ 5.00	100%	5	\$ 25.00
			Total	\$ 77.86
Reasonably Scavanged				
Material	price	% used	# req	cost
Mylar sheeting 25'x50"	\$ 37.15	25%	1	\$ 9.29
Plywood 4'x8'	\$ 18.45	100%	2	\$ -
flat black paint	\$ 3.00	100%	1	\$ 3.00
1" x 10' PVC	\$ 3.67	100%	1	\$ -
Misc fittings	\$ 5.00	100%	5	\$ 25.00
			Total	\$ 37.29
As Much as Possible Scavanged				
Material	price	% used	# req	cost
Mylar sheeting 25'x50"	\$ 37.15	25%	1	\$ 9.29
Plywood 4'x8'	\$ 18.45	100%	2	\$ -
flat black paint	\$ 3.00	100%	1	\$ 3.00
1" x 10' PVC	\$ 3.67	100%	1	\$ -
Misc fittings	\$ 5.00	100%	5	\$ 25.00
			Total	\$ 37.29

5.2 Bread Box Cost Analysis

Table 6: Bread Box Cost Analysis

Bread Box				
Everything Purchased				
Material	price	% used	# req	cost
Mylar sheeting 25'x50"	\$ 37.15	50%	1	\$ 18.58
Box	\$ 8.50	100%	1	\$ 8.50
Insulation	\$ 10.48	100%	4	\$ 41.92
1" X 10' PVC	\$ 3.67	100%	1	\$ 3.67
Paint	\$ 3.00	100%	3	\$ 9.00
insulation	\$ 10.48	100%	2	\$ 20.96
Glass	\$ 82.11	100%	1	\$ 82.11
Misc fittings	\$ 5.00	100%	5	\$ 25.00
			Total	\$ 209.74
Reasonably Scavanged				
Material	price	% used	# req	cost
Mylar sheeting 25'x50"	\$ 37.15	50%	1	\$ 18.58
Box	\$ 8.50	100%	1	\$ -
Insulation	\$ 10.48	100%	4	\$ -
1" X 10' PVC	\$ 3.67	100%	1	\$ -
Paint	\$ 3.00	100%	3	\$ 9.00
insulation	\$ 10.48	100%	2	\$ -
Glass	\$ 82.11	100%	1	\$ 82.11
Misc fittings	\$ 5.00	100%	5	\$ 25.00
			Total	\$ 134.69
As much as possible scavanged				
Material	price	% used	# req	cost
Mylar sheeting 25'x50"	\$ 37.15	50%	1	\$ 18.58
Box	\$ 8.50	100%	1	\$ -
Insulation	\$ 10.48	100%	4	\$ -
1" X 10' PVC	\$ 3.67	100%	1	\$ -
Paint	\$ 3.00	100%	3	\$ 9.00
insulation	\$ 10.48	100%	1	\$ -
Glass	\$ 82.11	100%	1	\$ -
Misc fittings	\$ 5.00	100%	5	\$ 25.00
			Total	\$ 52.58

5.3 Flat Plate Cost Analysis

Table 7: Flat Plate Cost Analysis

Flat Plate				
Everything Purchased				
Material	price	% used	# req	cost
Plywood 4'x8'	\$ 18.45	33%	1	\$ 6.09
Glass Sheet	\$ 10.38	100%	2	\$ 20.76
Paint	\$ 3.00	100%	2	\$ 6.00
insulation	\$ 10.48	100%	1	\$ 10.48
1" X 10' PVC ( 1" Spacing)	\$ 3.67	100%	6	\$ 22.02
Misc fittings	\$ 5.00	100%	5	\$ 25.00
			Total	\$ 90.35
Reasonably Scavanged				
Material	price	% used	# req	cost
Plywood 4'x8'	\$ 18.45	33%	1	\$ -
Glass Sheet	\$ 10.38	100%	2	\$ -
Paint	\$ 3.00	100%	2	\$ 6.00
insulation	\$ 10.48	100%	1	\$ -
1" X 10' PVC ( 1" Spacing)	\$ 3.67	100%	6	\$ -
Misc fittings	\$ 5.00	100%	5	\$ 25.00
			Total	\$ 31.00
As Much as Possible Scavanged				
Material	price	% used	# req	cost
Plywood 4'x8'	\$ 18.45	33%	1	\$ -
Glass Sheet	\$ 10.38	100%	2	\$ -
Paint	\$ 3.00	100%	2	\$ 6.00
insulation	\$ 10.48	100%	1	\$ -
1" X 10' PVC ( 1" Spacing)	\$ 3.67	100%	6	\$ -
Misc fittings	\$ 5.00	100%	5	\$ 25.00
			Total	\$ 31.00

#### 5.4 Cost Analysis Conclusion

All three designs, when scavanged, have very competitive costs. The bread box has the highest cost at \$52.58. However, this is only \$15.29 more expensive than the parabolic collector which costs \$37.29. The least expensive is the flat plate at \$31.00. It should be noted the cost is in no way a direct indicator of the best design.

## **6. Conclusion**

Based on the engineering analysis and cost analysis above, it is apparent that the parabolic collector with a passive circulation system has the best absorption/area/dollar ratio. This design also has a high likelihood of being able to be built by an average person that has an average knowledge of tools and building skills. This will be our final design and next semester (starting 13 JAN 2014) we plan to build several variations of this parabolic collector designs, such as a parabolic collector using black PVC piping, using galvanized steel piping and using black galvanized steel piping. For other applications, it would be more beneficial to use other variations of this collector. In a commercial application where water is in extremely high demand throughout the day, the circulation system should be bypassed entirely. This type of system would serve as a quick way to pre-heat the water. In a practical in-home use application, an active circulation system with a parabolic collector should be considered. This design would maximize the hot water output of the solar water heater.



## 7. Appendix

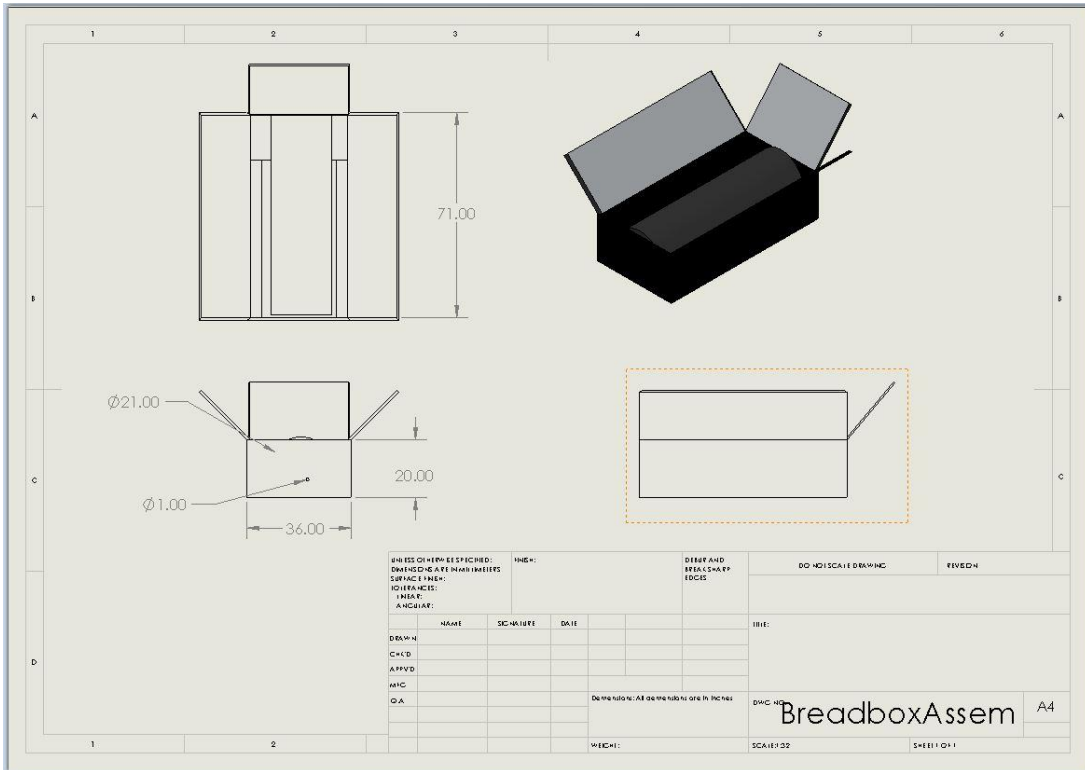

Figure 1: Bread box collector engineering drawing.



Figure 2: Parabolic collector engineering drawing.

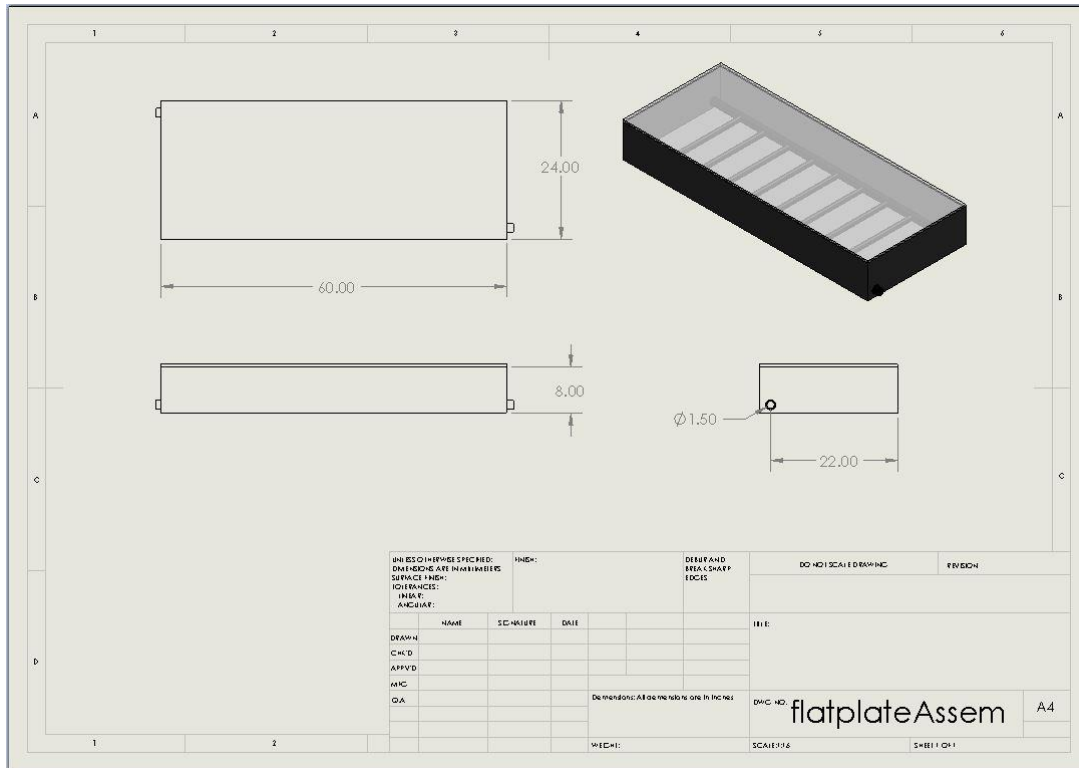

Figure 3: Flat plate collector engineering drawing.

## References

- Energy Protection Agency (EPA). (2013). *P3: People, Prosperity, and the Planet Student Design Competition for Sustainability*. Washington, DC: EPA. <http://www.epa.gov/P3/>. Accessed October 2013
- U.S. Department of Energy (DOE). (2012). *Building Energy Codes Program*. Washington, DC:
- U.S. Department of Energy. <http://www.energycodes.gov/adoption/states/>. Accessed October 2013.
- Raisul Islam, K. Sumathy and S. Ullah Khan, "Solar water heating systems and their market trends," *Renewable and Sustainable Energy Reviews*, vol. 17, pp. 1-25, 1, 2013.
- U.S. Department of Energy (DOE). (2005). *Residential Energy Consumption Survey 2005*. Washington, DC: Energy Information Administration. <http://www.eia.doe.gov/emeu/recs/>. Accessed October 2013.
- Energy Information Administration (EIA). (2005). *Office of Energy Markets and End Use, Forms EIA-457 A-G of the 2005 Residential Energy Consumption Survey*. Washington, DC: EIA.
- American Society of Heating and Air-Conditioning Engineers (ASHRAE). (1987). *Methods of Testing TO DETERMINE THE SOLAR PERFORMANCE OF SOLAR DOMESTIC WATER HEATING SYSTEMS*. Atlanta, GA: ASHREA Standard- 95.

- American Society of Heating and Air-Conditioning Engineers (ASHRAE). (1987). *Methods of Testing to Determine the Performance of Solar Collectors*. Atlanta, GA: ASHREA Standard-93.
- M. Raisul Islam, K. Sumathy, Samee Ullah Kahn. (2012). *Solar water heating systems and their market trends*. Atlanta, GA: Renewable and Sustainable Energy Reviews. <http://www.elsevier.com/locate/rser/>. Accessed October 2013.
- Database of State Incentives for Renewables and Efficiency (DSIRE). (2012). *Arizona Incentives/Policies for Renewables and Efficiency*. Raleigh, NC: North Carolina State University.
- <http://www.dsireusa.org/incentives/index.cfm?re=0&ee=0&spv=0&st=0&srp=1&state=AZ/>. Accessed October 2013.
- U.S. Department of Energy (DOE). (2012). *Building Codes and Regulations for Solar Water Heaters*. Washington, DC: U.S. Department of Energy. <http://energy.gov/energysaver/articles/building-codes-and-regulations-solar-water-heating-systems/>. Accessed October 2013.
- U.S. Department of Energy (DOE). (2012). *Building Energy Codes Program*. Washington, DC: U.S. Department of Energy. <http://www.energycodes.gov/adoption/states/>. Accessed October 2013.
- Energy Protection Agency (EPA). (2013). *P3: People, Prosperity, and the Planet Student Design Competition for Sustainability*. Washington, DC: EPA. <http://www.epa.gov/P3/>. Accessed October 2013

### **Project Website**

<http://www.cefns.nau.edu/capstone/projects/ME/2014/ULC-SolarWaterHeater/index.html>