

Shell Eco-marathon

By

Abdul Alshodokhi, Moneer Al-Jawad, Jericho Alves, John Gamble,
Nikolaus Glassy, Benjamin Kurtz, & Travis Moore
Team 14

Progress Report

Document

*Submitted towards partial fulfillment of the requirements for
Mechanical Engineering Design II – Spring 2014*



Department of Mechanical Engineering
Northern Arizona University
Flagstaff, AZ 86011

Contents

1. Introduction.....	2
2. Frame Modifications.....	2
3. Drivetrain Modifications	3
4. Work Breakdown.....	5
5. Project Timeline	7
6. Conclusion	7
7. References	7
8. Appendix A	8

Figures

Figure 1	3
Figure 2	3
Figure 3	4
Figure 4	5

1. Introduction:

The Shell Corporation puts on an annual competition that focuses on increasing the efficiency of fossil fueled vehicles and increasing the interest as well as the efficiency of renewable energy vehicles. The competition will be held in Houston, TX in late April. The prototype vehicle that competes will have to meet the rules and regulations set out by Shell. The purpose of this project outlined by the team's client is to design, build, and compete well with a prototype vehicle that will achieve the highest fuel economy possible.

Client:

The primary client for this project is Dr. John Tester at Northern Arizona University (NAU). Dr. Tester is involved with the student chapter of Society of Automotive Engineers (SAE). Dr. Tester has been the academic advisor for the Shell Eco-Marathon for previous competitions. The secondary client for this project is the student chapter SAE because most of the funding is coming directly from the student chapter SAE's budget.

Need Statement:

Due to the significant number of vehicles running on finite resources as a means of transportation, it has become necessary to research and develop means to stretch those finite resources further. The Shell Corporation has sponsored a competition to promote this research and development in the field of fuel efficiency. The scope of this project is to design, build, test, and present a vehicle that conforms to the set requirements and constraints to produce a vehicle that will produce extremely high fuel efficiency.

Modifications:

A few modifications were made to the prototype design of the vehicle. These modifications were made to the frame and drivetrain to eliminate some problems of the original design.

2. Frame Modifications

Due to the changes in the designs of other subsystems, primarily the drivetrain and steering, it was determined that the frame design needed to be modified in order to accommodate new space requirements.

Issues with the current design were found when the secondary driver sat in the driving position initially determined by our primary driver. In order to increase the driving comfort and visibility the roll bar angle was increased raising the driver into a more upright position. This change also allows more room for the steering components whose location is still yet to be

determined. The rear triangle of the frame was also modified in two ways. The first modification involved raising the rear axle mounting point which will keep the vehicle as low to the ground as possible reducing the overall frontal cross sectional area. The second modification involved stretching the rear triangle out further in order to allow more room for the drivetrain which will require an intermediate shaft to achieve the correct ratio in between the output shaft of the engine and the final drive sprocket. These changes can be seen below in figures 1 and 2 which show the first and second versions of the frame, respectively.

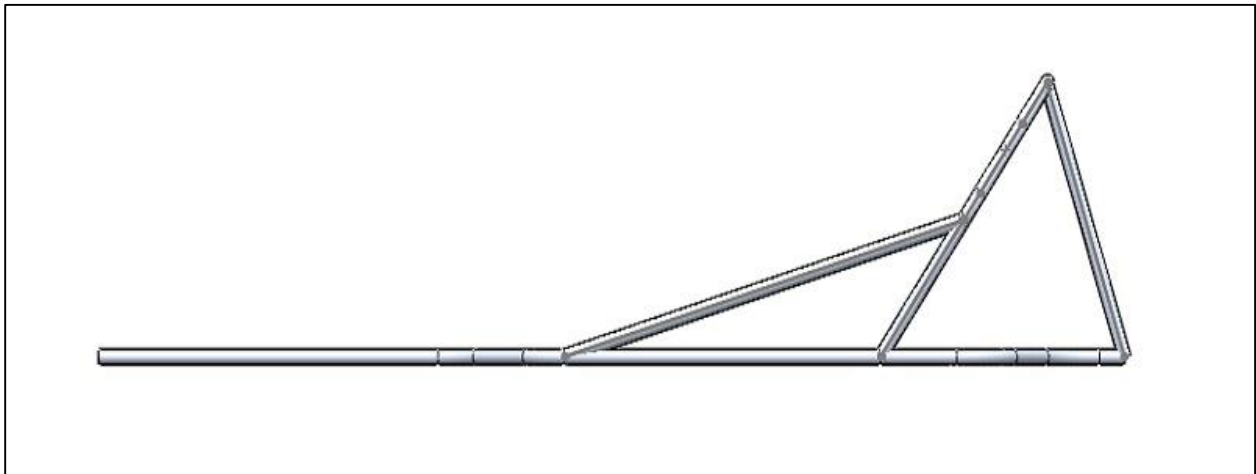

Figure 1: Frame V1/ Original Design

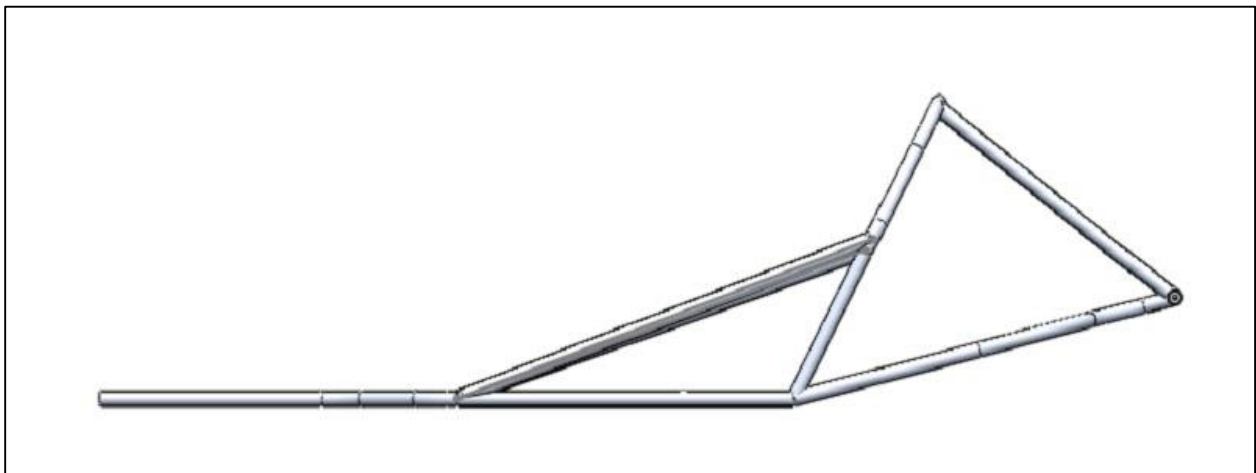

Figure 2: Frame V2/ Revised Design

3. Drivetrain Modifications

The only primary change to the drivetrain is a new clutch. The previous clutch design is two gears connected with a chain roller and the third gear meshed with them. A meshed gear will

cause a lot of tooth wear on the gear and vehicle lurching. A mechanical meshed clutch is prone to low reliability and a large amount of noise. Figure 3 shows the meshed gear clutch.

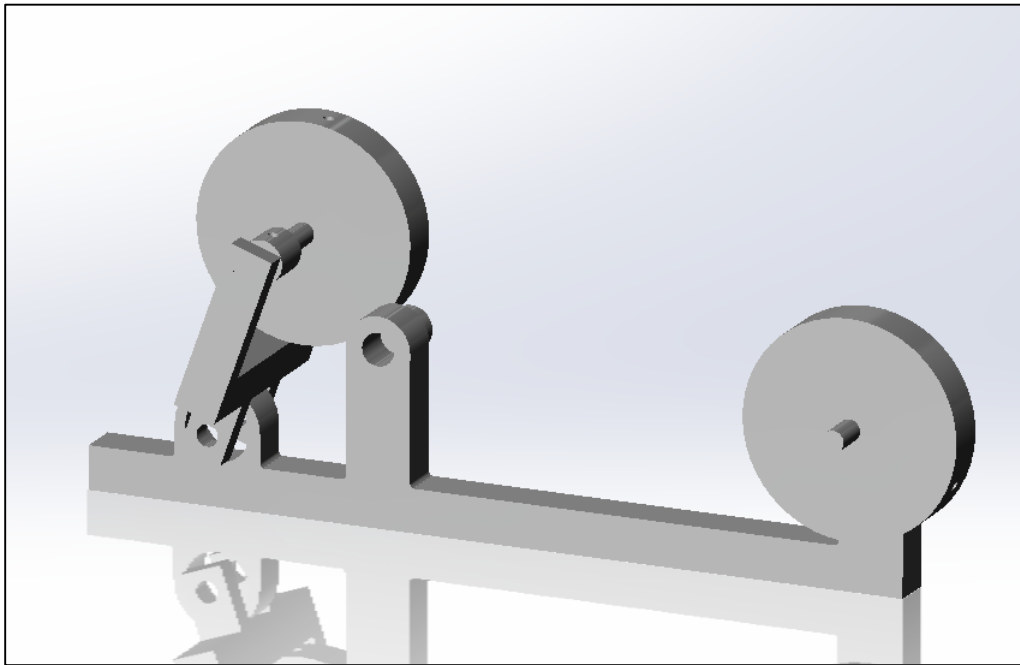

Figure 3: Meshed gear clutch

A centrifugal clutch will be used instead of a meshed gear clutch. This clutch is used mostly with a minimum of 1600 RPM, depending on the type of the centrifugal clutch. Basically, the centrifugal clutch deals with the centrifugal force which connects the inner piece of the clutch with the outer piece while the engine cycles at 1600 RPM or above, and will disengage when the RPM is lower than that, when the engine is off while coasting. The centrifugal clutch will prevent mechanical problems caused by meshing, which will increase the life of the clutch. Figure 4 shows the centrifugal clutch.



Figure 4: Centrifugal clutch [1].

The centrifugal clutch is faster to install compared to the meshed clutch. Another advantage is that the centrifugal clutch is also lighter than the meshed clutch. Therefore, our team will use the centrifugal clutch instead of the meshed clutch.

4. Work Breakdown

The following is a breakdown of technical tasks for the remainder of the semester along with project updates of each task.

Frame - Jericho, Nik, Travis. As previously mentioned, a few modifications were made to the frame of the vehicle. The current frame is designed on SolidWorks and the materials are going to be ordered within this week. Once the materials arrive, construction of the frame will begin in the machine shop

Fairing - Jericho, Nik, Ben. The construction of the plug for the fairing will also begin alongside the construction of the frame but is of a lesser priority as vehicle testing can begin without the presence of the completed fairing.

Fuel, Engine, Tuning - Travis, John. On January 30th, John will test the engine and fuel systems in a lab from Dr. Ciocanel. Further testing will occur once the frame skeleton is constructed.

Electrical - Travis, John, Ben. Fuel injection systems along with miscellaneous switches need to be installed to the car. This is going to occur once the frame assembly is complete.

Drivetrain - Abdul, Travis, John. Design of the drivetrain is nearly complete. The centrifugal clutch is ordered. Assembly locations on the frame need to be designed and bought.

Steering & Braking - Moneer, Ben, Jericho. The braking system is already designed for the vehicle. Steering design is ongoing. Once the frame skeleton is assembled, the steering and braking systems can be installed to the vehicle.

5. Project Timeline

A project timeline for the remainder of the project is shown in Appendix A. An upcoming deliverable set for Shell is due Friday, January 31st. From now until March 1st, the frame, fairing, all systems of the vehicle will be constructed and installed. Testing will begin March 1st and will continue until the weekend of the competition. The competition is listed as a milestone on April 25th. The walk through presentations is shown as a milestone on April 14th.

6. Conclusion

The goal of the Shell Eco-marathon competition is to design, construct, and present a vehicle that maximizes fuel efficiency. By designing, constructing, and presenting this vehicle, progress will be made toward sustainable fuel energy in vehicles.

The proposed frame revisions will allow for greater flexibility in drivetrain and steering designs which have not been completely finalized. The remainder of the mounting tabs have not been included in current revisions because the final designs of the steering system, intermediate shaft, engine location, ect. have not been finished.

A centrifugal clutch will be used instead of a meshed clutch. The centrifugal clutch is more reliable and will be exposed to less mechanical wear. The centrifugal clutch will also be lighter and quieter, however the engine must be running at 1600 RPM for the clutch to engage.

Technical tasks for the remainder of the semester are divided up and already progressing. At minimum, two people are assigned to each task. The next steps in the project are to provide the next deliverables to Shell, order and assemble the frame of the vehicle, and begin construction of the plug for the fairing.

7. References

- [1]. Heeters Performance Center, "Centrifugal Clutches for Go-Karts and Mini Bikes," <http://www.heeters.com/kartclutches.shtml>, Jan. 2014.

[2].Appendix A – Gantt Chart

