

Shell Eco-marathon

By
Jericho Alves, Benjamin Kurtz, Moneer Al-Jawad, &
Daniel Chief
Team 14A

Engineering Analysis Document

*Submitted towards partial fulfillment of the requirements for
Mechanical Engineering Design I – Fall 2013*



Department of Mechanical Engineering
Northern Arizona University
Flagstaff, AZ 86011

Contents

- 1. Introduction.....3**
- 2. Chassis/Fairing Analysis3**
 - 2.1. Chassis Rigidity5
- 3. Steering Analysis6**
 - 3.1. Ackermann Steering Geometry.....6
 - 3.2. Rolling Resistance9
- 4. Braking Analysis10**
- 5. Project Update.....14**
- 6. Conclusion15**
- 7. References.....15**
- 8. Appendices.....16**
 - 8.1. Appendix A.....16
 - 8.2. Appendix B17

1. Introduction:

All engineering designs require an engineering analysis. Cars especially are very complicated designs in all aspects. These aspects account for all parts that a vehicle will be made of. Also, the following analyses determine the best selected designs to build the current Shell Eco-marathon vehicle. The main objective of the Shell Eco-marathon competition is to build an economic car that maximizes fuel efficiency. The main considerations for Team14A are the fairing design, steering design, and braking design.

2. Chassis Analysis

The main focus when analyzing the aerodynamic performance of the vehicle fairing is the overall frontal area. The area is largely a function of driver positioning and visibility requirements. Both drivers that are going to be going to the competition are measured in a seated position to find the greatest angle they could be reclined to and maintain adequate visibility and driver comfort. A vector diagram of the proposed driving position is then made and overall height requirements of the fairing are determined. This can be seen in Figure 1 below.

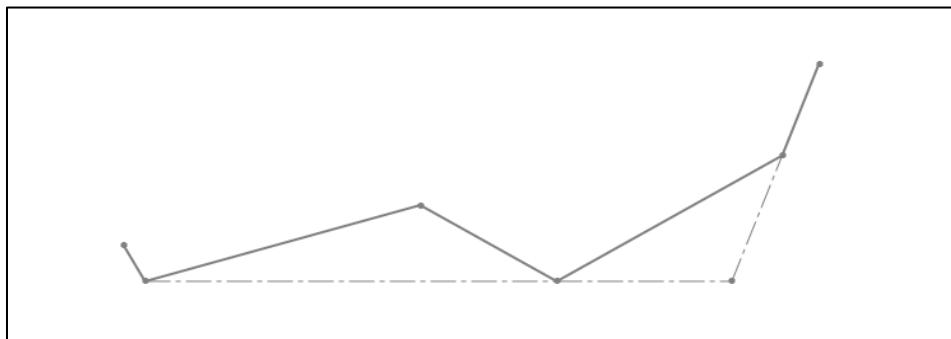

Figure 1: Driver Position Diagram

The frontal area is then calculated as a function of the seatback angle using a uniform width of .6 meters which allows for the width of the drivers shoulders and a high density foam side bolster. This is represented in Figure 2 below.

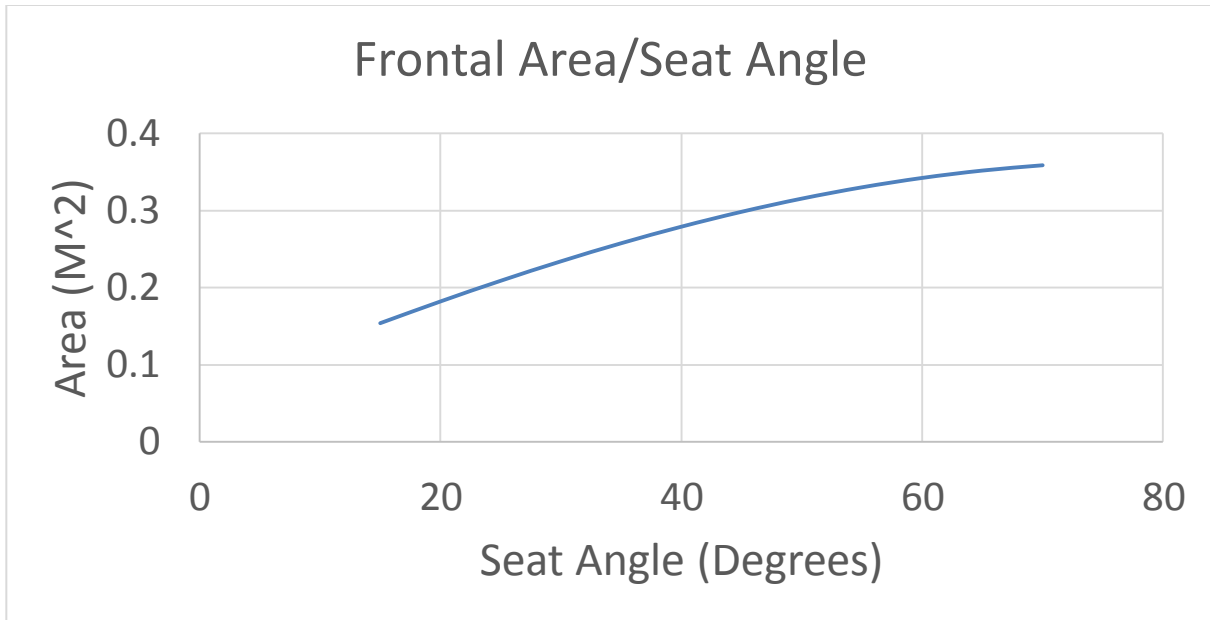

Figure 2: Frontal Area/Seat Angle

The drag force is calculated over a range of frontal areas in order to see the drag effects over the entire range of speeds the vehicle would see. The coefficient of drag (Cd) is initially set to 0.09 which is the standard for a streamlined half body.

Drag Force
$$F_D = \frac{1}{2} \rho v^2 C_D A \tag{2.1}$$

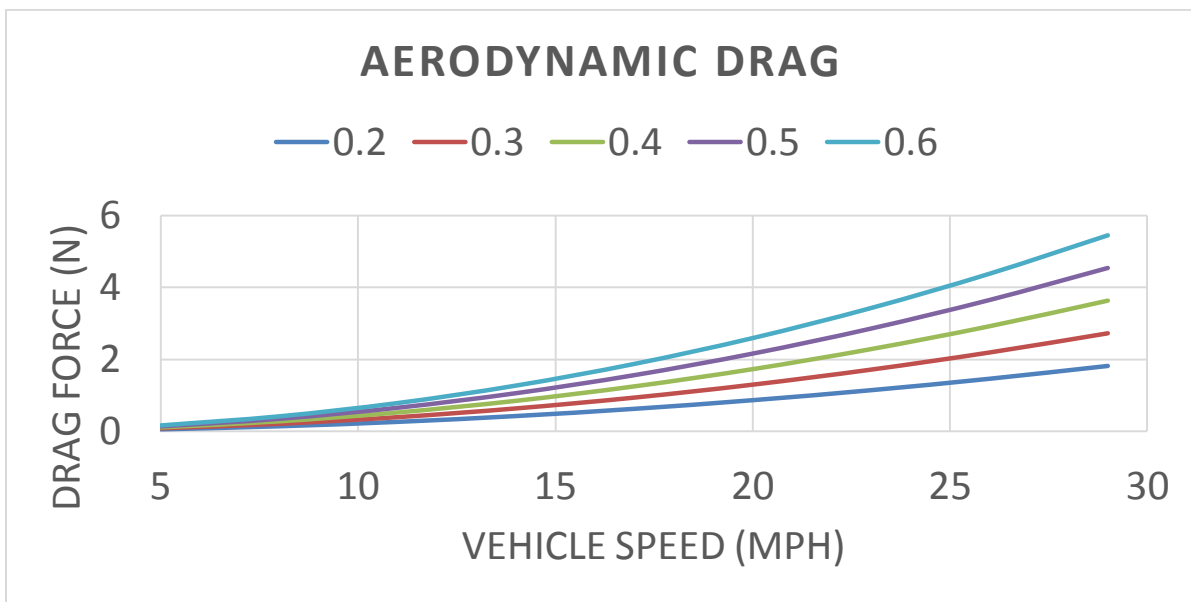

Figure 3: Force of Aerodynamic Drag

Additional fluid mechanics based considerations determine the overall shape. To maintain an ideal streamlined body the fairing tail section reduction should not exceed 22 degrees in the YZ or XZ plane to ensure flow separation does not occur. Flow separation causes turbulent vortices to form increasing the drag force acting on the body. The chassis floor should taper between 3-4 degrees towards the rear of the vehicle to reduce turbulence of the merging flow paths coming from above and below the vehicle. [1]

2.1. Chassis Rigidity

Chassis rigidity is determined by taking a cross section of the shell at the center of mass including a 55kg driver seated in the standard position. The polar moment of inertia is taken at this point and used to determine overall chassis deflection and its location using the following equations.

$$\text{Maximum Deflection} \quad \delta_{max} = \frac{F a (L^2 - a^2)^{3/2}}{9\sqrt{3}LEI} \quad (2.1)$$

$$\text{Point of Maximum Deflection} \quad x_1 = \sqrt{\frac{L^2 - a^2}{3}} \quad (2.3)$$

The cross section evaluated at point a is 0.6 meters from the rear wheel. Initial wheelbase dimensions are somewhat arbitrary as all components have not been finalized. The elastic modulus is determined from a mean value of multiple 3000 weaves from multiple carbon fiber manufacturers.

Variable	Value
a (Load to nearest support)	.6 m
L (Wheelbase)	2.5 m
X (Point of maximum deflection)	1.484 m
E (Elastic Modulus)	141 GPa
I (Moment of Inertia)	.079 m ⁴

Load at a	Maximum deflection at x
60 kg	1.19 mm
90 kg	1.78 mm
120 kg	2.37 mm

3. Steering

The Eco-marathon vehicle does not encounter high speeds and is required a minimum turning radius of 8 meters. The turning radius will be calculated by using the Ackermann steering geometry. Rolling resistance is determined by using the rolling resistance coefficient. This will determine the choice of our engine, wheel and tire size.

3.1. Ackermann Steering Geometry

The course will have a few turns so we need to calculate the required radius to make the turn. To determine the radius, Ackermann steering geometry is used. Ackermann geometry is

used to solve the problem of slippage of the tires when following the path of the turn. At low speed the wheels primarily roll without slip angle. The Ackermann steering geometry works by turning the steering pivot points to the inside, so there is a line drawn from the kingpin to the center of the rear tire [2]. The steering pivot point is joined by the tire rods and sometimes includes the rack and pinion. To calculate the radius, the wheels will have a common center point. The center point is an extended line from the rear axle as shown in Figure 4. It intersects with extended lines from the front axles while the wheels are turned inwards. Correct Ackermann steering reduces tire wear and is easy on terrain [3].

$$\cot\delta_o - \cot\delta_i = \frac{w}{l}$$

δ_i is the steering angle of the inner wheel.

δ_o is the steering angle of the outer wheel.

w is the distance between the steer axes of the steering wheel (track).

l is the distance between the front and rear axles (wheelbase).

The inner and outer steer angles δ_i and δ_o can be calculated by:

$$\tan\delta_i = \frac{l}{R_1 - \frac{w}{2}}$$

$$\tan\delta_o = \frac{l}{R_1 + \frac{w}{2}}$$

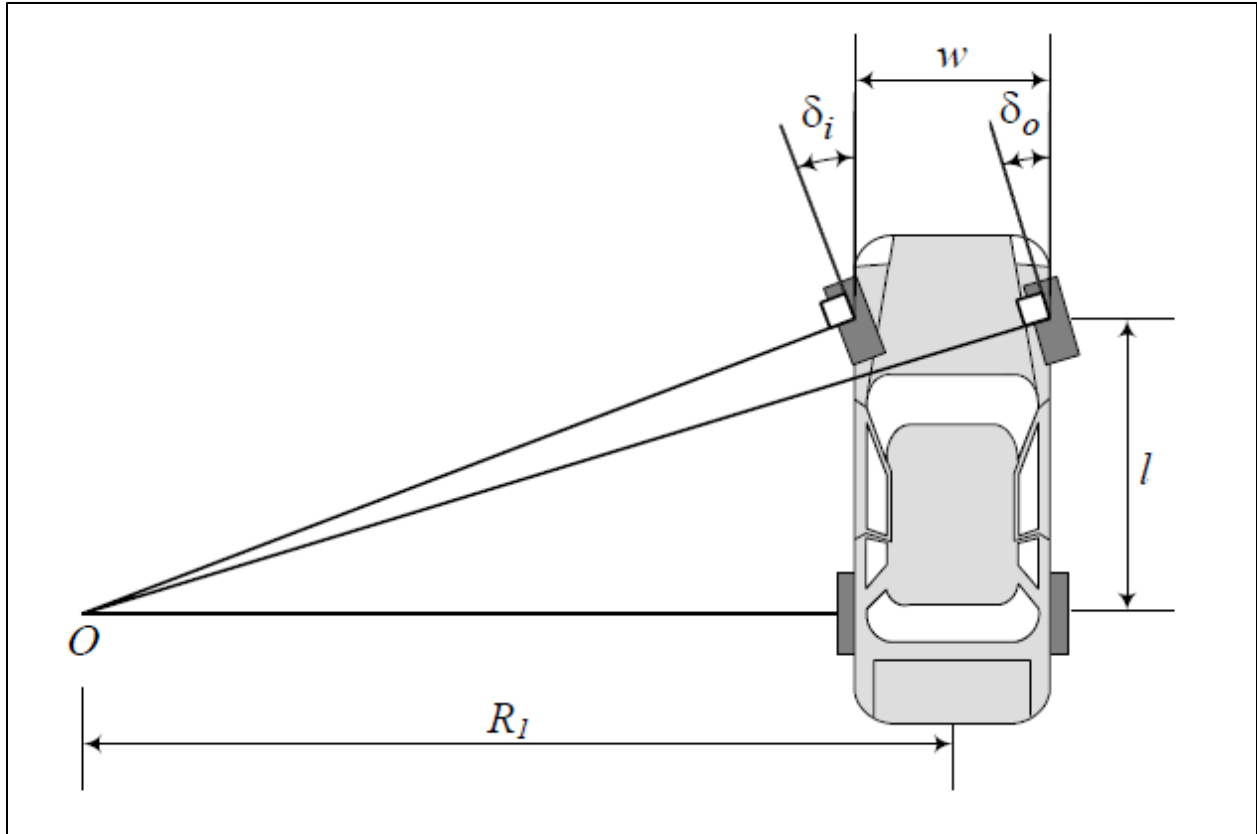

Figure 4: Front-wheel steering and the Ackermann condition

The mass center of a steered vehicle will turn on a circle with radius R:

$$R = \sqrt{a_2^2 + l^2 \cot^2 \delta}$$

The track also known as the the width(w) was given in the rule book, as shown in Figure 5. The width of the vehicle must be between 100 cm to 130 cm. The wheelbase also known as length(l) is required to be, between 220 cm – 230cm. Delta is these measurements on provided on an excel spreadsheet, in Appendix A.

With delta calculated, R is calculated by the equation above. The center of mass (a) equals 120cm. Using an excel spreadsheet, the maximum value of R is l equal to 100cm and w equal to 350cm, provided in Appendix B. Radius (r) equal to 11.98m. The minimum requirement is 8 m so anything above will work.

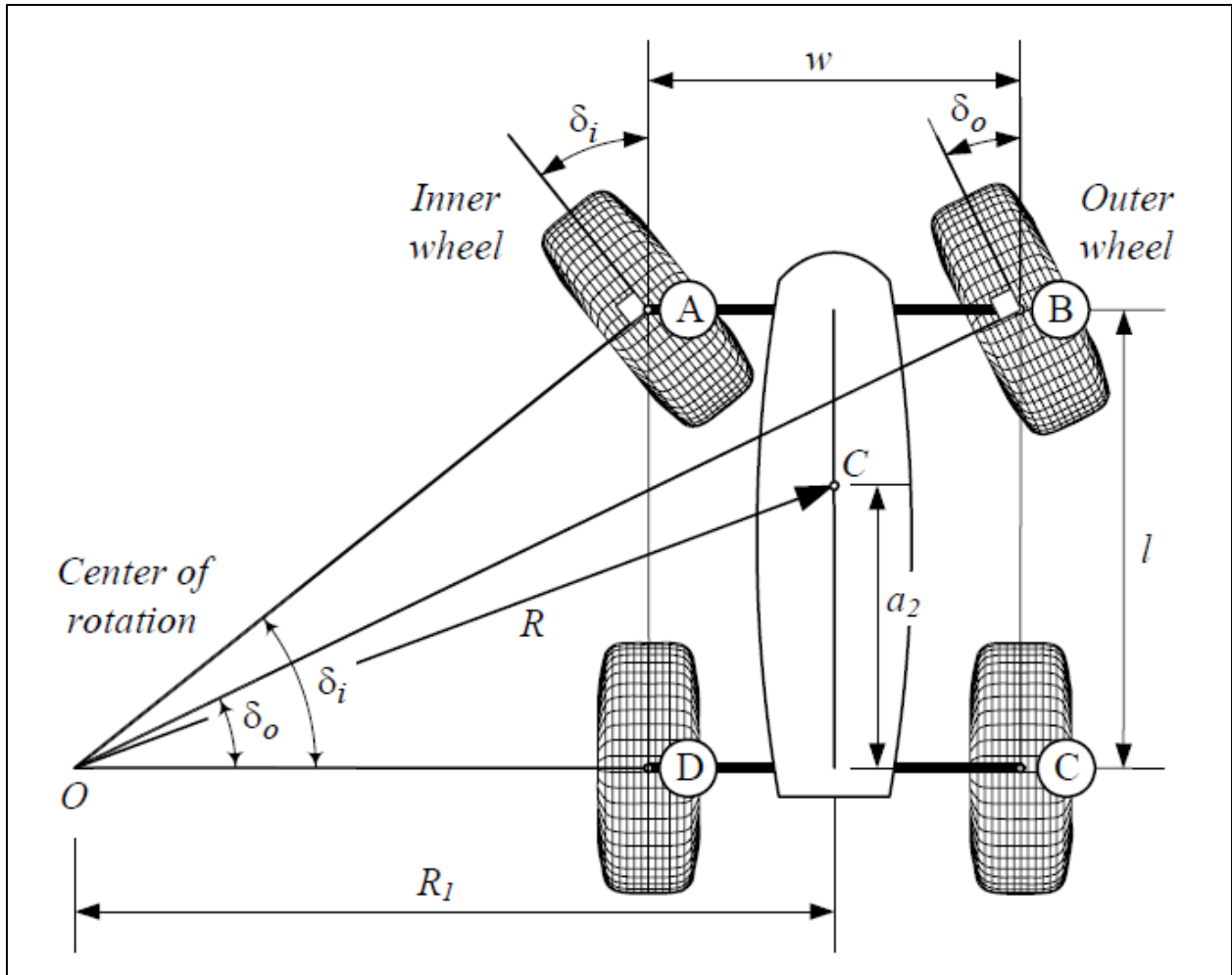

Figure 5: Steering angles of inner and outer wheels

3.2. Rolling Resistance

Rolling resistance is the force resisting the motion when a body (such as a tire, wheel or ball) rolls on a surface. Hysteresis is the main cause of rolling resistance. Hysteresis is when the energy of deformation is greater than the energy of recovery. The repeated cycle of the tire rotating results in loss if hysteresis, this is the main cause of energy loss. To keep the vehicle moving and above required speed the rolling resistance coefficient is used [4]. In determining the rolling resistance coefficient, the suffice engine size will be selected. Also, the rolling friction will be minimized. Factors that affect rolling resistance are tire pressure, tire diameter, tire thread. The higher the tire pressure the less deformation so there is less rolling resistance. The

smaller diameter of tire the higher rolling resistance. The wider the tire the less rolling resistance.

The smoother the tire thread, the better rolling resistance.

The rolling resistance coefficient is determined by: $F=C_{rr}N$.

F is the rolling resistance force.

C_{rr} is the dimensionless rolling resistance coefficient or coefficient of rolling friction.

The coefficient of rolling friction can be calculate by: $C_{rr}=(z/d)^{1/2}$.

z is the sinkage depth.

d is the diameter of the rigid wheel.

N is the normal force, the force perpendicular to the surface on which the wheel is rolling.

Tires that have done well in the past competition had diameter of 20 inches. The coefficient of rolling friction (C_{rr}) is 0.0055.

Torque is the amount of force needed to rotate an object about an axis [5]. To determine the torque needed we use the equation: $T=Fr$ [6].

F is the rolling resistance coefficient.

r is the radius of the wheel.

4. Braking Analysis

The Shell Eco-marathon competition rulebook states that each braking system must hold the car and driver in place on a 20% grade slope. A 20% grade slope translates to 11.31° . This is our main constraint for braking. Along with meeting the parking constraint, the weight of the braking system needs to be minimized in order to maximize fuel efficiency. The following analysis on the braking system is modeled after an article on the physics of braking systems [7]. The article was published by a braking design company called StopTech Systems.

The weight of the driver and car is assumed to be concentrated at a single point load of 1128 N located 1.2 meters away from the rear edge of the car and 0.27 meters above the bottom of the car. Zero slip is assumed to be between the wheels and the road. All mechanical components are assumed to be rigid with 100% efficiency. The free body diagram shown in Figure 6 shows the distributed forces on the car.

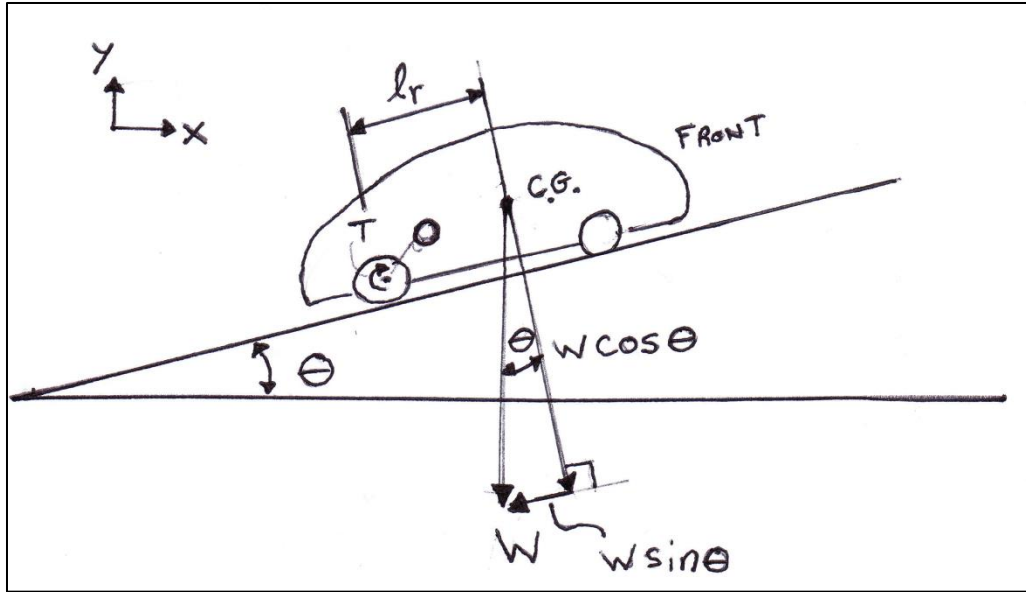

Figure 6: Entire Car Free Body Diagram

Shell requires at least two independent braking systems for each vehicle. Each braking system is required to hold the weight of the car on a 20% grade slope. The rear braking needs to provide more force than the front braking system. This is due to a larger distance between the car's center of gravity and the rear braking system than the distance between the center of gravity and the front braking system. This results in a larger torque on the rear braking system. The rear braking system only consists of one set of calipers rather than two sets on the front braking system.

Summing the moments around point O shows the required parking torque. The parking torque required by the rear braking, T_r , is equal to the tangent component of the weight, $w \sin \theta$, multiplied by the distance between the car's center of gravity and the rear axle, l_r .

$$T_r = l_r w \sin \theta \quad (4.1)$$

From a closer look at the rear rotor, the torque needed to keep the car in place is determined by the clamping force of the calipers. The free body diagrams shown in Figure 7 and Figure 8 show this information.

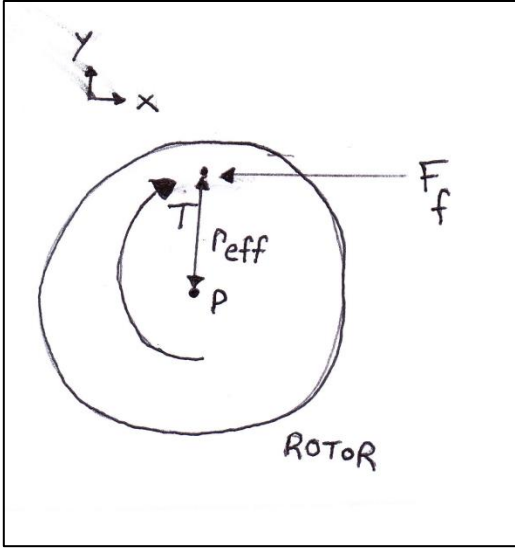

Figure 7: Rotor FBD

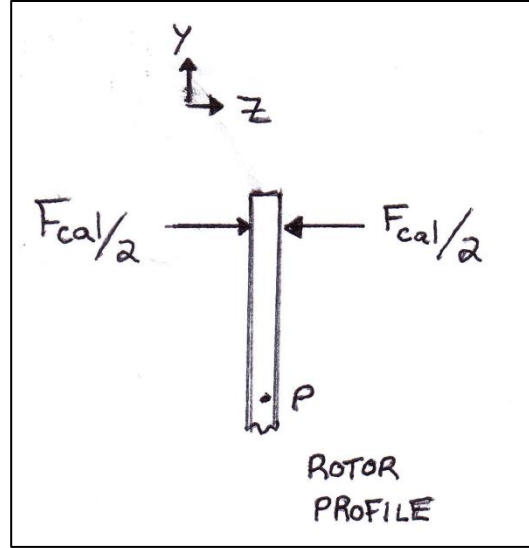

Figure 8: Rotor Profile FBD

Summing the moments around point P shows that torque on the rotor from the weight of the car, Tr , is equal to the friction force provided by the calipers, F_f , multiplied by the effective radius between the center of the rotor and the center of the caliper, r_{eff} .

$$Tr = F_f r_{eff} \quad (4.2)$$

The friction force from the caliper, F_f , is equal to the forces of both sides of the caliper multiplied by the coefficient of friction between the brake pad of the caliper and the rotor, μ_{bp} .

$$F_f = \mu_{bp} F_{cal} \quad (4.3)$$

From military standard 1472F, which includes standards for human design, the 5th percentile grip strength on a lever at $5\pi/6$ degree elbow flexion is 222 Newtons for the left hand, as shown in Figure 9 and Table 1 [8].

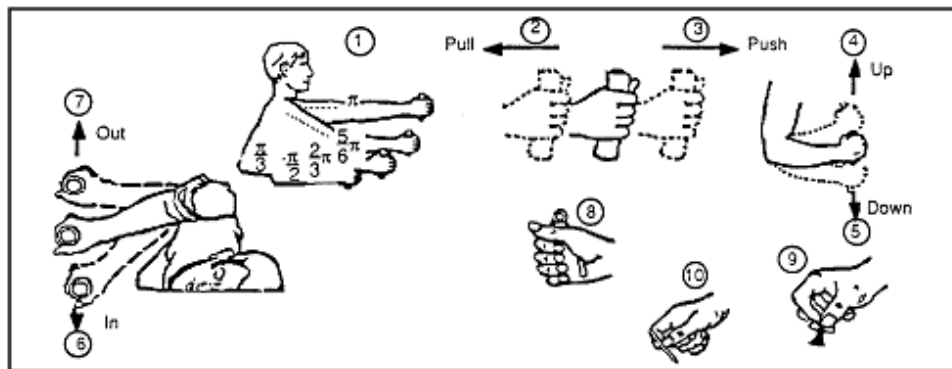

Figure 9: Arm, Hand, and Thumb/Finger Strength (5th Male Percentile)

Table 1: Hand and Thumb/Finger Strength

(1)	(2)		(3)		(4)		(5)		(6)		(7)	
Degree of elbow flexion (rad)	Pull		Push		Up		Down		In		Out	
	L**	R**	L	R	L	R	L	R	L	R	L	R
π	222	231	187	222	40	62	53	75	58	89	36	62
$5/6 \pi$	187	249	133	187	57	80	80	89	67	89	36	67
$2/3 \pi$	151	137	116	160	76	107	93	116	89	98	45	67
$1/2 \pi$	142	165	98	160	76	89	93	116	71	80	45	71
$1/3 \pi$	116	107	96	151	67	89	80	89	76	89	53	76

Hand and thumb-finger strength (N)

The left hand number is used for the analysis because it is typically the weaker hand and thus our minimum force exerted on the lever arm. Assuming 100% mechanical efficiency between the braking lines and components, the force by one side of caliper onto the rotor, F_{cal} is equal to the left hand lever force, F_l , multiplied by the ratio of the applied force radius, r_{force} , and the radius of the lever arm, r_{arm} .

$$F_{cal} = F_l \frac{r_{force}}{r_{arm}}$$

The mechanical clamping force due to the both sides of the caliper is equal to twice the force from one side.

$$F_{clamp} = 2 X F_{cal}$$

The coefficient of friction can be calculated from combining equations (4.1), (4.2), and (4.3), while substituting the known values of F_{cal} , w , l_r , θ , r_{eff} .

$$\mu_{bp} F_{clamp} r_{eff} = l_r w \sin \theta$$

$$\mu_{bp} (9768N)(.070m) = (1.2 m)(1128 N) \sin (11.31^\circ)$$

From the previous equation, $\mu_{bp} = .388$, which is the minimum coefficient of friction needed to hold the car in place. The brake pad friction coefficient for semi-metallic brake pads ranges from 0.26 -0.38. Semi-metallic brake pads for bikes are cheaper than organic or carbon brake pads. NAU's previous Shell Eco-marathon car used MX2 brakes made by Hayes. Each braking component weighs 340 g, which compares to most high performance brakes and satisfies the objective for the current design. Standard sizes for rotors are 160mm, 185mm, and 203mm. The size of the rotor depends on weight and the applied forces onto the rotor. Smaller rotor sizes are beneficial because they are light weight. The rotors used on the previous car are 160mm in diameter and made from aluminum, which is perfect for the current design.

5. Project Update

As shown in Figure 10, the schedule has not changed in the previous three weeks. The process of ordering the chassis/fairing materials as well as the steering components has just begun.

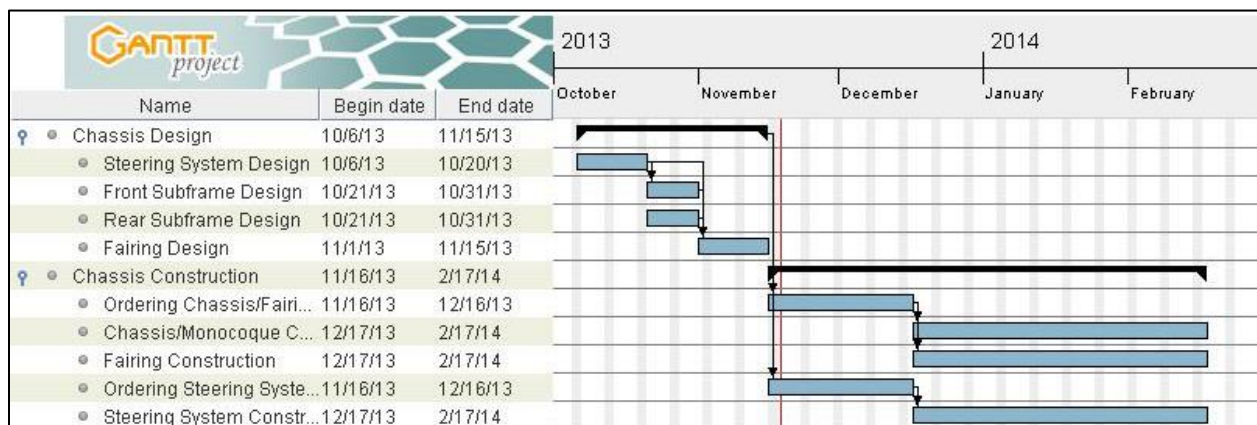

Figure 10: Gantt chart

6. Conclusion

The chassis will be designed with the driver as far reclined as possible while still maintaining adequate visibility and comfort. By minimizing the projected area on the front plane the aerodynamic drag at lower speed is negligible.

The fairing, as designed, exhibits very little deflection under the applied loads. With internal structures and seat supports added, the structure would only become more rigid.

Steering turn radius required by rules and regulation should be a minimum of 8 meters. Appendix B shows the calculation of track width (w) divided by wheelbase (l). Anything over 8 meters is acceptable. The main braking constraint is that each braking system needs to hold the car in place on a 20% grade slope. Most mountain bike disc brake systems provide enough force to hold the car at the given slope. Semi-metallic brake pads are the most ideal material for the braking system due to their relatively low cost, medium ranged friction coefficient, and their durability. The rotors from the previous year car will work at 160mm.

7. References

- [1]. B. Jawad, E. Marck, D. Tingley, T. Salvati, J. McCoy, A. Ondes, E. Posta, V. Floma. "Best Practice for an SAE SUPERMILAGE Vehicle," 2001-01-2469, SAE International, Costa Mesa, CA, 2001.
- [2]. Wikipedia. "Ackermann Steering Geometry"
http://en.wikipedia.org/wiki/Ackermann_steering_geometry#cite_ref-Norris.2C_Modern_Steam_Road_Wagons.2C_Ackermann_steering_2-0. 2013
- [3]. Longoria, R. G. "Steering and Turning Vehicles–2." (2013).
- [4]. "ETH - IDSC - Institute for Dynamic Systems and Control." ETH - IDSC - Institute for Dynamic Systems and Control. N.p., n.d. Web. 17 Nov. 2013.
- [5]. "Rolling Resistance." Wikipedia. Wikimedia Foundation, 17 Nov. 2013. Web. 17 Nov. 2013.
- [6]. "Low Rolling Resistance Tires." - Transport Canada. N.p., n.d. Web. 17 Nov. 2013.
- [7]. J. Walker, Jr., "The Physics of Braking Systems" (1st Ed.)
<http://www.stoptech.com/docs/media-center-documents/the-physics-of-braking-systems>, 2005.
- [8]. Department of Defense Design Criteria Standard: Human Defense, MIL-STD-1472F, 1999.

8. Appendices

8.1. Appendix A: Delta values for various widths and lengths:

6 = w/l	Wheelbase l (cm)												
	240	250	260	270	280	290	300	310	320	330	340	350	
track w (cm)	100	0.416667	0.4	0.384615	0.37037	0.357143	0.344828	0.333333	0.322581	0.3125	0.30303	0.294118	0.285714
	101	0.420833	0.404	0.388462	0.374074	0.360714	0.348276	0.336667	0.325806	0.315625	0.306061	0.297059	0.288571
	102	0.425	0.408	0.392308	0.377778	0.364286	0.351724	0.34	0.329032	0.31875	0.309091	0.3	0.291429
	103	0.429167	0.412	0.396154	0.381481	0.367857	0.355172	0.343333	0.332258	0.321875	0.312121	0.302941	0.294286
	104	0.433333	0.416	0.4	0.385185	0.371429	0.358621	0.346667	0.335484	0.325	0.315152	0.305882	0.297143
	105	0.4375	0.42	0.403846	0.388889	0.375	0.362069	0.35	0.33871	0.328125	0.318182	0.308824	0.3
	106	0.441667	0.424	0.407692	0.392593	0.378571	0.365517	0.353333	0.341935	0.33125	0.321212	0.311765	0.302857
	107	0.445833	0.428	0.411538	0.396296	0.382143	0.368966	0.356667	0.345161	0.334375	0.324242	0.314706	0.305714
	108	0.45	0.432	0.415385	0.4	0.385714	0.372414	0.36	0.348387	0.3375	0.327273	0.317647	0.308571
	109	0.454167	0.436	0.419231	0.403704	0.389286	0.375862	0.363333	0.351613	0.340625	0.330303	0.320588	0.311429
	110	0.458333	0.44	0.423077	0.407407	0.392857	0.37931	0.366667	0.354839	0.34375	0.333333	0.323529	0.314286
	111	0.4625	0.444	0.426923	0.411111	0.396429	0.382759	0.37	0.358065	0.346875	0.336364	0.326471	0.317143
	112	0.466667	0.448	0.430769	0.414815	0.4	0.386207	0.373333	0.36129	0.35	0.339394	0.329412	0.32
	113	0.470833	0.452	0.434615	0.418519	0.403571	0.389655	0.376667	0.364516	0.353125	0.342424	0.332353	0.322857
	114	0.475	0.456	0.438462	0.422222	0.407143	0.393103	0.38	0.367742	0.35625	0.345455	0.335294	0.325714
	115	0.479167	0.46	0.442308	0.425926	0.410714	0.396552	0.383333	0.370968	0.359375	0.348485	0.338235	0.328571
	116	0.483333	0.464	0.446154	0.42963	0.414286	0.4	0.386667	0.374194	0.3625	0.351515	0.341176	0.331429
	117	0.4875	0.468	0.45	0.433333	0.417857	0.403448	0.39	0.377419	0.365625	0.354545	0.344118	0.334286
	118	0.491667	0.472	0.453846	0.437037	0.421429	0.406897	0.393333	0.380645	0.36875	0.357576	0.347059	0.337143
119	0.495833	0.476	0.457692	0.440741	0.425	0.410345	0.396667	0.383871	0.371875	0.360606	0.35	0.34	
120	0.5	0.48	0.461538	0.444444	0.428571	0.413793	0.4	0.387097	0.375	0.363636	0.352941	0.342857	
121	0.504167	0.484	0.465385	0.448148	0.432143	0.417241	0.403333	0.390323	0.378125	0.366667	0.355882	0.345714	
122	0.508333	0.488	0.469231	0.451852	0.435714	0.42069	0.406667	0.393548	0.38125	0.369697	0.358824	0.348571	
123	0.5125	0.492	0.473077	0.455556	0.439286	0.424138	0.41	0.396774	0.384375	0.372727	0.361765	0.351429	
124	0.516667	0.496	0.476923	0.459259	0.442857	0.427886	0.413333	0.4	0.3875	0.375758	0.364706	0.354286	
125	0.520833	0.5	0.480769	0.462963	0.446429	0.431034	0.416667	0.403226	0.390625	0.378788	0.367647	0.357143	
126	0.525	0.504	0.484615	0.466667	0.45	0.434483	0.42	0.406452	0.39375	0.381818	0.370588	0.36	
127	0.529167	0.508	0.488462	0.47037	0.453571	0.437931	0.423333	0.409677	0.396875	0.384848	0.373529	0.362857	
128	0.533333	0.512	0.492308	0.474074	0.457143	0.441379	0.426667	0.412903	0.4	0.387879	0.376471	0.365714	
129	0.5375	0.516	0.496154	0.477778	0.460714	0.444828	0.43	0.416129	0.403125	0.390909	0.379412	0.368571	
130	0.541667	0.52	0.5	0.481481	0.464286	0.448276	0.433333	0.419355	0.40625	0.393939	0.382353	0.371429	

8.2. Appendix B: R values for various widths and lengths:

R= $\sqrt{a^2 + l^2} + \cot^2 2\theta \sqrt{l/2}$	Wheelbase l (cm)															
	240	250	260	270	280	290	300	310	320	330	340	350	360	370	380	
100	555.8287	603.7601	653.8165	705.9791	760.2327	816.5646	874.9643	935.423	997.9331	1062.488	1129.083	1197.714	1267.381	1338.074	1409.893	1482.837
101	549.9294	597.3639	646.9048	698.5335	752.2344	807.9947	865.8038	925.6528	987.5339	1051.441	1117.368	1185.311	1255.279	1327.279	1401.312	1477.389
102	544.1422	591.089	640.1245	691.2294	744.3883	799.5882	856.8181	916.0651	977.3335	1040.605	1105.878	1173.147	1243.421	1315.701	1390.087	1466.58
103	538.4637	584.9322	633.4716	684.0629	736.6901	791.3401	848.002	906.6666	967.3261	1029.974	1094.605	1161.214	1230.892	1302.639	1376.455	1452.34
104	532.8909	578.8899	626.9427	677.0299	729.1355	783.2461	839.3507	897.44	957.5062	1019.543	1083.544	1149.505	1217.527	1287.611	1359.757	1434.065
105	527.4207	572.9588	620.5341	670.1266	721.7203	775.3016	830.8594	888.3843	947.8684	1009.305	1072.688	1138.013	1205.286	1274.617	1346.004	1419.549
106	522.0502	567.1359	614.2423	663.3494	714.4406	767.5025	822.5237	879.4947	938.4075	999.2552	1062.052	1126.733	1193.307	1261.884	1332.563	1405.446
107	516.7766	561.4182	608.0643	656.6947	707.2927	759.8447	814.3392	870.7665	929.1185	989.3885	1051.57	1115.659	1181.747	1249.944	1320.351	1393.068
108	511.5973	555.8026	601.9967	650.1591	700.2729	752.3243	806.3016	862.1952	919.9968	979.6995	1041.297	1104.785	1170.272	1237.859	1307.646	1379.733
109	506.5096	550.2865	596.0366	643.7393	693.3776	744.9374	798.407	853.7765	911.0377	970.1835	1031.208	1094.106	1158.993	1225.979	1295.166	1366.653
110	501.5111	544.867	590.181	637.4322	686.6035	737.6805	790.6514	845.5063	902.2367	960.8356	1021.297	1083.616	1147.893	1214.228	1282.721	1353.471
111	496.5994	539.5416	584.4271	631.2348	679.9473	730.55	783.0311	837.3805	893.5897	951.6514	1011.56	1073.309	1136.986	1202.693	1270.53	1340.607
112	491.7722	534.3078	578.7723	625.1441	673.4058	723.5426	775.5425	829.3953	885.0924	942.6265	1001.992	1063.182	1126.299	1191.444	1258.727	1328.248
113	487.0272	529.1632	573.2138	619.1573	666.976	716.655	768.182	821.5469	876.7409	933.7566	992.588	1053.23	1115.827	1180.474	1247.281	1316.348
114	482.3622	524.1054	567.7491	613.2717	660.6549	709.8839	760.9464	813.8317	868.5313	925.0377	983.3446	1043.447	1105.456	1169.579	1235.924	1304.601
115	477.7752	519.1321	562.3759	607.4845	654.4398	703.2265	753.8322	806.2464	860.4601	916.4658	974.2573	1033.829	1095.282	1158.715	1224.228	1291.921
116	473.2643	514.2412	557.0917	601.7934	648.3278	696.6798	746.8365	798.7874	852.5235	908.0371	965.322	1024.373	1085.584	1148.857	1214.291	1281.924
117	468.8273	509.4306	551.8943	596.1958	642.3164	690.2408	739.9561	791.4516	844.7181	899.748	956.5349	1015.073	1075.366	1137.715	1202.228	1268.941
118	464.4626	504.6982	546.7814	590.6893	636.403	683.907	733.1882	784.2358	837.0406	891.5949	947.8921	1005.927	1066.62	1129.071	1193.284	1259.257
119	460.1682	500.0421	541.751	585.2717	630.5851	677.6756	726.5299	777.137	829.4878	883.5743	939.39	996.9291	1057.282	1119.815	1184.528	1251.401
120	455.9424	495.4604	536.8009	579.9407	624.8604	671.5441	719.9784	770.1524	822.0565	875.683	931.0251	988.077	1047.82	1109.271	1172.524	1237.687
121	451.7835	490.9512	531.9293	574.6942	619.2265	665.5099	713.5312	763.279	814.7438	867.9178	922.794	979.3668	1038.617	1099.266	1161.921	1225.874
122	447.69	486.5127	527.1341	569.5302	613.6812	659.5708	707.1856	756.5141	807.5468	860.2755	914.6935	970.7948	1028.584	1089.133	1151.348	1214.221
123	443.6601	482.1434	522.4136	564.4465	608.2223	653.7244	700.9392	749.8551	800.4625	852.7532	906.7202	962.3578	1019.65	1079.699	1141.414	1203.787
124	439.6924	477.8414	517.7658	559.4414	602.8478	647.9685	694.7896	743.2994	793.4883	845.3479	898.8713	954.0524	1010.183	1068.316	1128.559	1189.001
125	435.7854	473.6051	513.1892	554.5128	597.5556	642.3008	688.7344	736.8446	786.6215	838.0569	891.1435	945.8755	1003.007	1059.14	1117.388	1177.641
126	431.9377	469.4331	508.6819	549.659	592.3439	636.7194	682.7715	730.4882	779.8596	830.8774	883.5342	937.8241	994.065	1049.907	1108.251	1168.504
127	428.1478	465.3238	504.2424	544.8783	587.2106	631.2221	676.8985	724.2279	773.2002	823.8068	876.0404	929.8951	985.936	1041.877	1098.901	1158.024
128	424.4144	461.2758	499.8691	540.1688	582.1539	625.807	671.1136	718.0615	766.6407	816.8425	868.6596	922.0857	977.926	1031.877	1088.921	1147.074
129	420.7363	457.2876	495.5604	535.529	577.1721	620.4722	665.4145	711.9868	760.1789	809.9821	861.3889	914.3932	967.926	1020.077	1075.121	1131.274
130	417.1121	453.3578	491.3149	530.9573	572.2635	615.2158	659.7993	706.0017	753.8126	803.2232	854.226	906.8147	959.826	1011.437	1064.051	1117.765