

SAE Mini Baja

Project Proposal

Chris Bennett, Eric Lockwood, Anthony McClinton,
Robin McRee, Colin Pemberton

December 9, 2013

Overview

- Project Introduction
- Needs Statement and Project Goals
- Objectives, Constraints, and QFD
- Concept Generation and Selection
- Engineering Analysis
- Cost Analysis
- Final Frame Design
- Spring 2014 Project Plan
- Conclusion

Project Introduction

- 2014 SAE Baja Competition
- Customer is SAE International
- Create international design standards
- Hold various collegiate design competitions
- Stakeholder is NAU SAE
- Project advisor is Dr. John Tester

Need Statement

- NAU has not won an event at the SAE Baja competition in many years.
- Goal of the frame team is to design the lightest possible frame within the SAE Baja rules.
- Goal changes to overall vehicle safety compliance after completion of the frame.

Design Objectives

- Minimize frame weight
- Minimize cost
- Maximize safety
- Maximize manufacturability

Constraints

- AISI 1018 tubing or equivalent strength
- Frame length less than 108 inches
- Frame width less than 40 inches
- Frame height less than 41 inches above seat bottom
- Frame geometry must conform to all SAE Baja Rules

QFD Matrix

Customer Needs	Customer Weights	Length	Width	Height	Weight	Bending Strength	Bending Stiffness	Tubing Wall Thickness	Conform to Safety Regulations	Cost	Man-Hours to Build
		Light weight	10	3	3	3	9	3	3	9	
Easy to manufacture	6	1	1	1				3	3		9
Inexpensive	5				9	9	9	3		9	
No damage after impact	8	3	3	3		9	9	3	9		
Safe	10					9	9	1	9		1
	Raw score	60	60	60	135	237	237	157	180	75	64
	Relative Weight	5%	5%	5%	11%	19%	19%	12%	14%	6%	5%
	Unit of Measure	in	in	in	lb	N-m	N-m ²	in	T/F	\$	hr
	Technical Target	108	40	41	200	395	2789	0.062	TRUE	300	40

Operating Environment

- Cinders OHV Area
- El Paso Gas Pipeline Service Road
- NAU Building 98C
- NAU Parking Lot 64



Image Credit: Stu Olsen's Jeep Site

Concept Generation

- Tubing Selection
- Frame Geometry

Tubing Selection

- SAE specifies AISI 1018 Steel
 - 1" Outside Diameter
 - 0.120" Wall Thickness
- Other Sizes Allowed
 - Equivalent Bending Strength
 - Equivalent Bending Stiffness
 - 0.062" Minimum Wall Thickness

Bending Strength and Stiffness

$$\textit{Stiffness} = E \cdot I$$

$$\textit{Strength} = \frac{S_y \cdot I}{c}$$

$E = 29,700$ ksi for all steel

$I =$ second moment of area

$S_y =$ yield strength

$c =$ distance from neutral axis to extreme fiber

AISI 1018

Diameter [in]	Wall Thickness [in]	Stiffness [in-lb]	Strength [in ² -lb]
1.000	0.120	971.5	3.513

AISI 4130

Diameter [in]	Wall Thickness [in]	Stiffness [%]	Strength [%]	Weight [%]
1.000	0.120	100	118	100
1.125	0.083	113	119	81.9
1.125	0.095	126	131	92.7
1.250	0.065	130	122	72.9
1.375	0.065	176	150	80.6
1.500	0.065	231	181	88.3

Final Selection

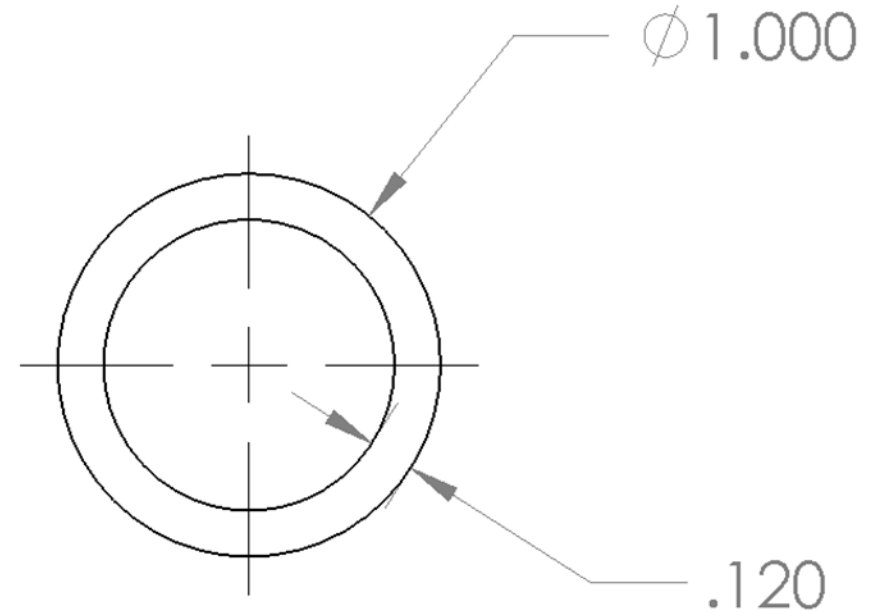
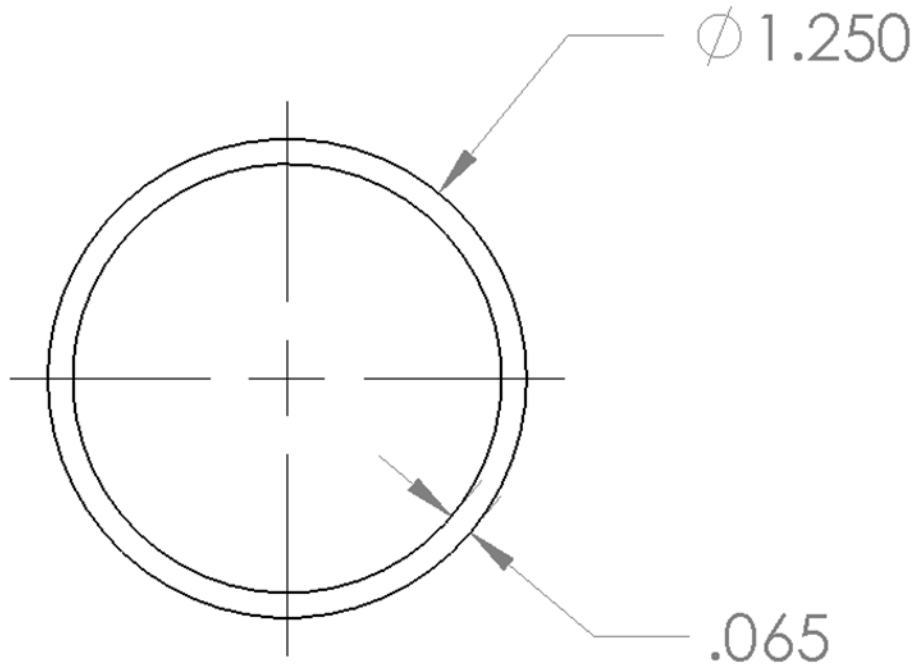

Frame Geometry

- Four initial design concepts
- Evaluated with design targets from QFD
- Decision matrix of raw data
- Lowest score is best

Design 1

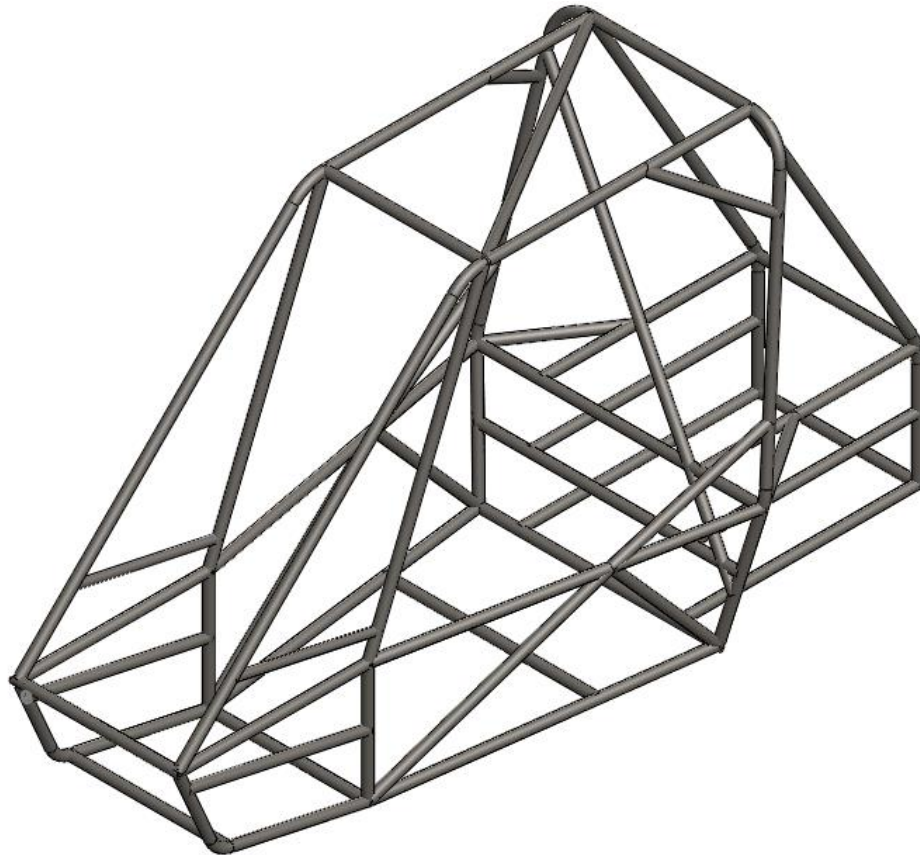

Design 2

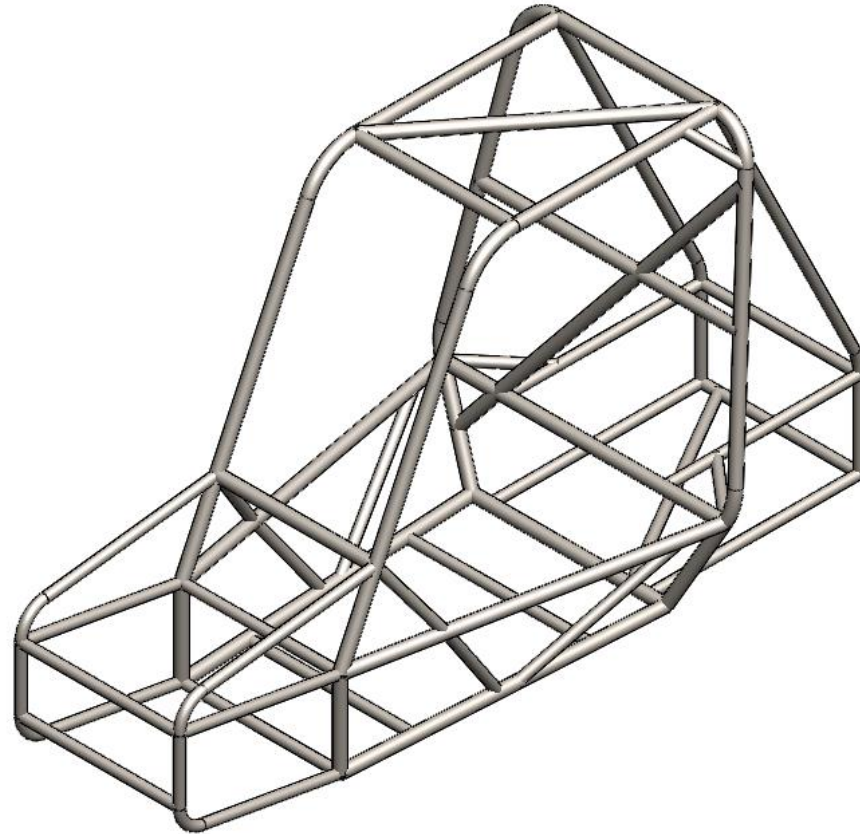

Design 3

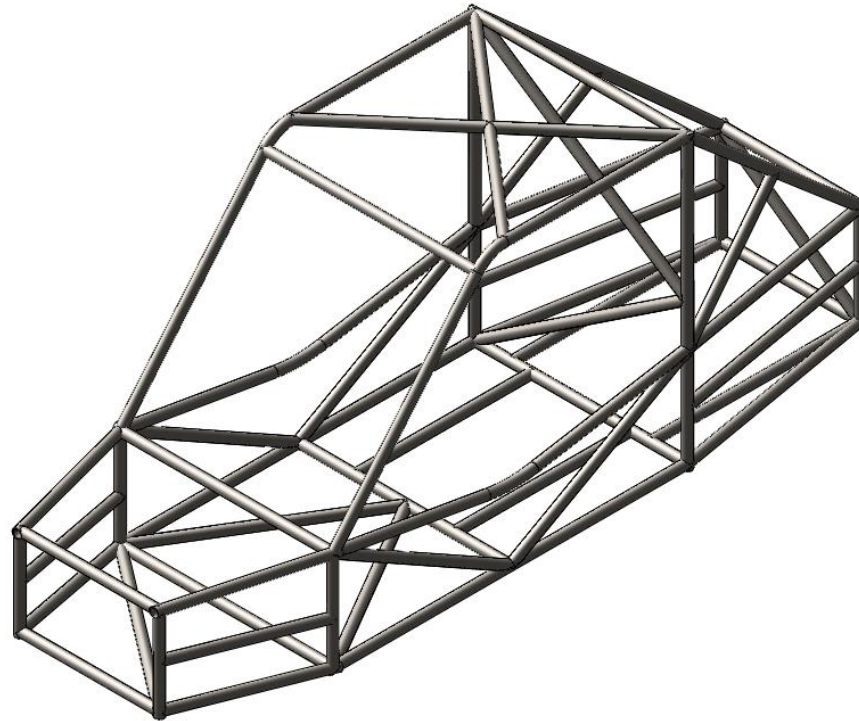

Design 4

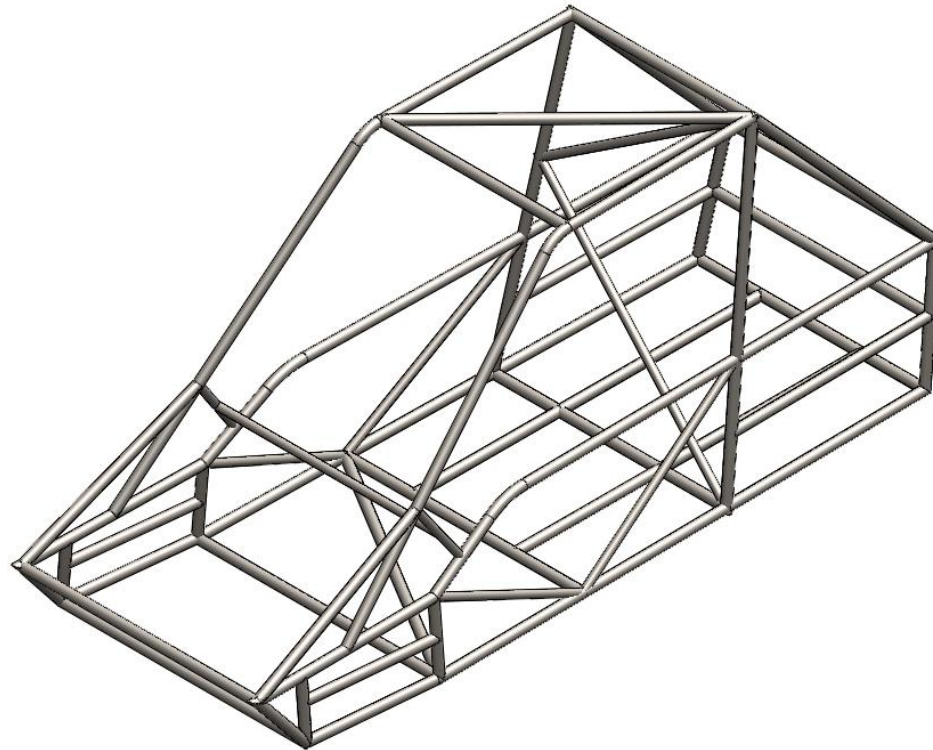

Frame Design Criteria

- Amount of material [feet]
- Length [inches]
- Width [inches]
- Height [inches]
- Number of Bends
- Number of individual tubes

Decision Matrix

	Weight	Design 1	Design 2	Design 3	Design 4
Amount of Material [ft]	9	109	94	105	107
Length [in]	5	83	78	100	100
Width [in]	1	32	33	30	31
Height [in]	5	45	44	39	44
Number of Bends	1	10	10	4	4
Number of individual tubes	1	65	43	50	55
Total		1728	1542	1724	1773

Final Design Concept

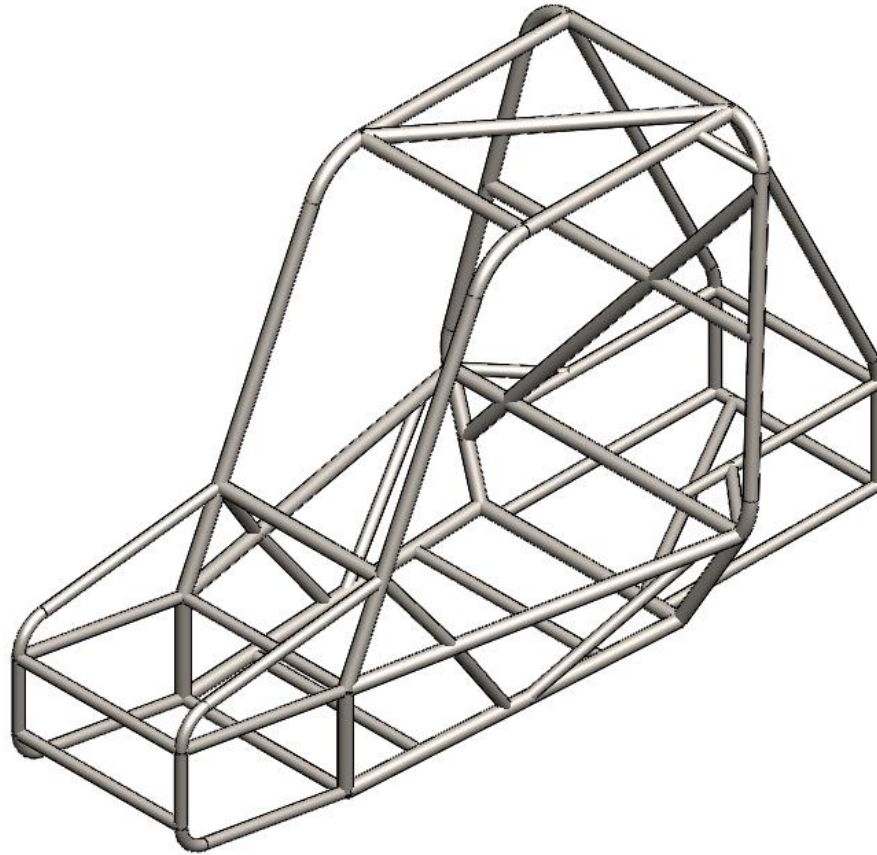

Engineering Analysis

- SolidWorks Simulation
- Simple Loading Case
- Frame Impact Analysis
- Engineering Design Target Evaluation

Frame Impact Analysis

- Drop Test
- Front Collision Test
- Rear Collision Test
- Side Impact Test
- Static simulations at maximum impact acceleration
- All are worst-case scenario

Drop Test

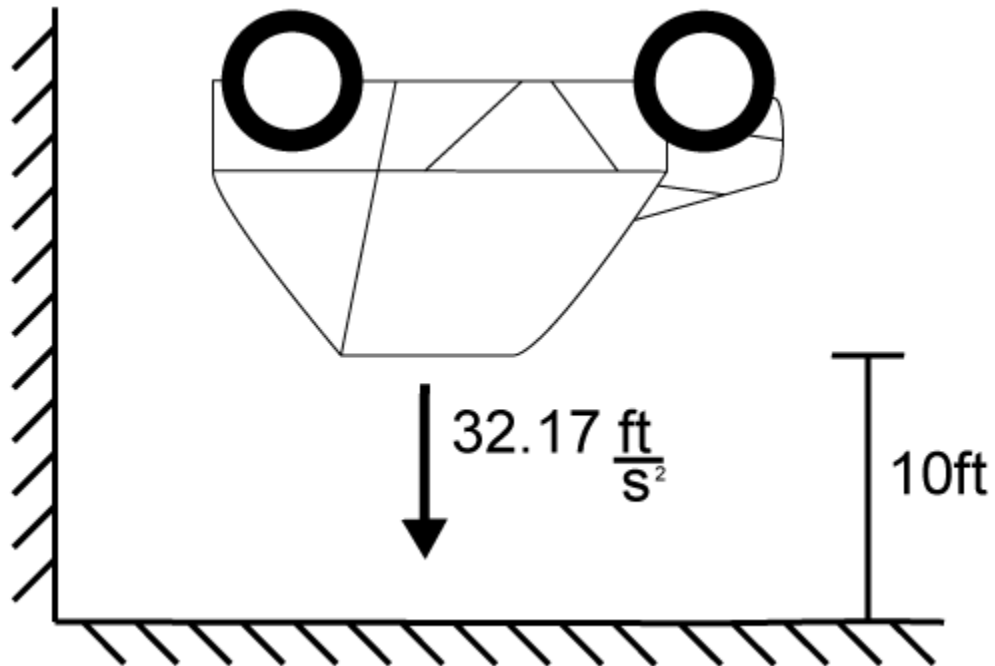

Drop Test

$$F = m \cdot \frac{\sqrt{gh}}{t}$$

- F = force
- m = mass
- g = acceleration of gravity
- h = drop height
- t = impulse time

Front Collision Test

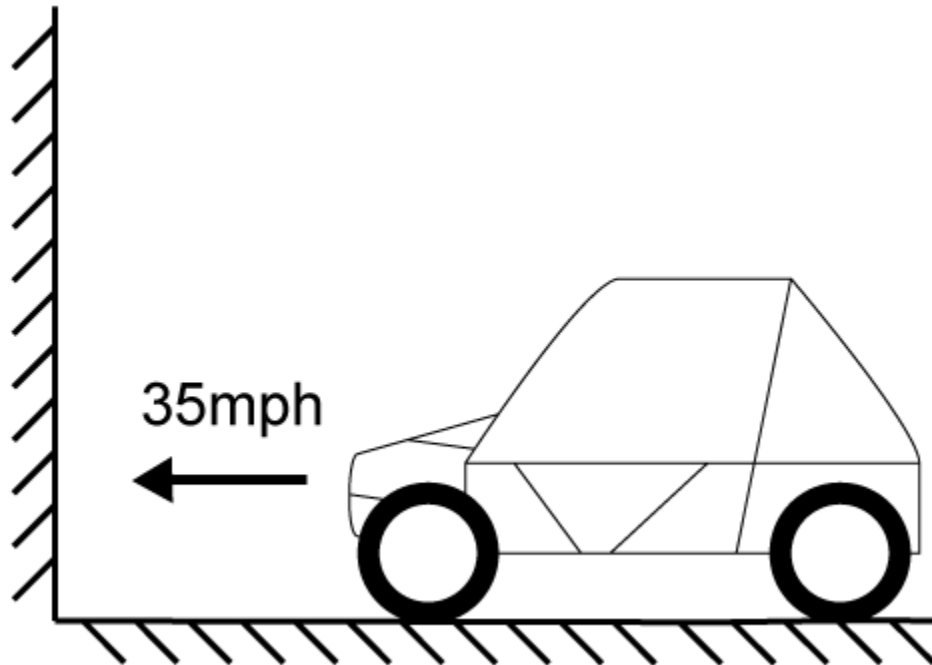

Rear Collision Test

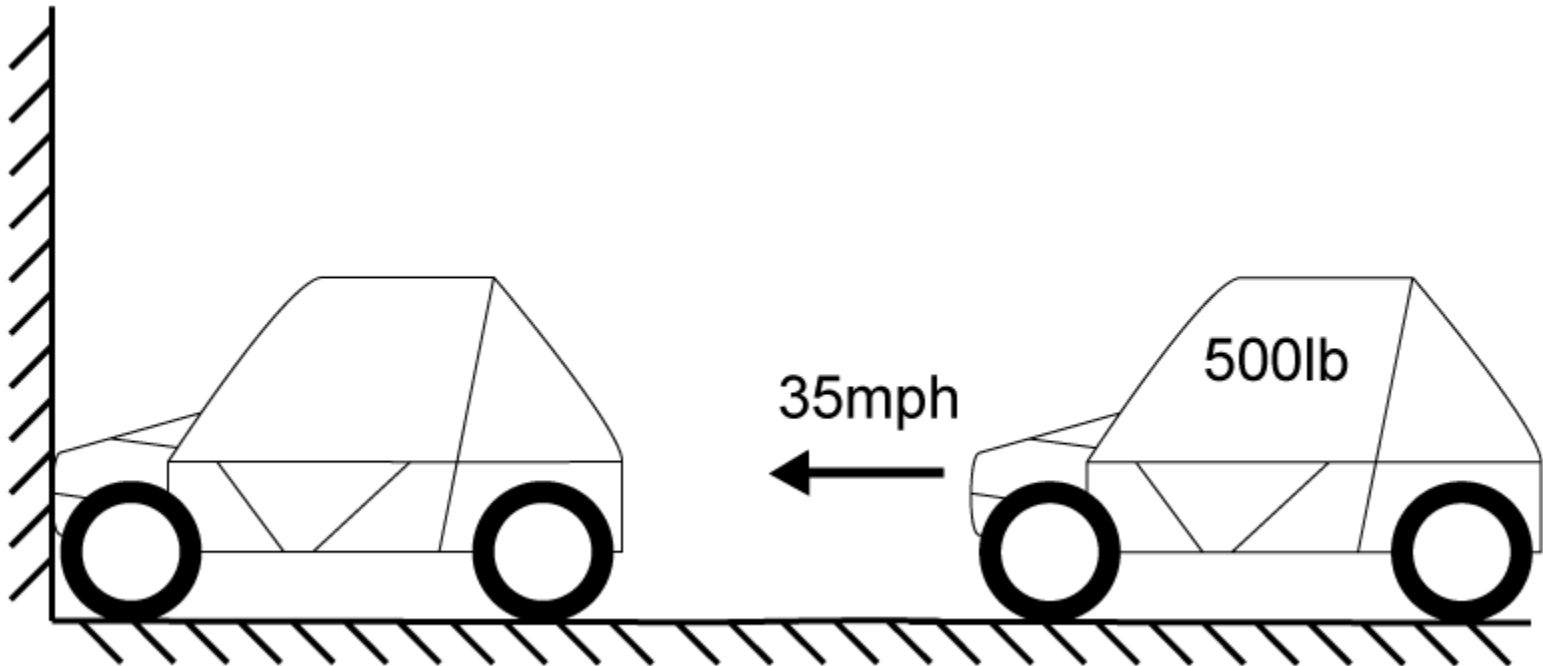

Side Impact Test

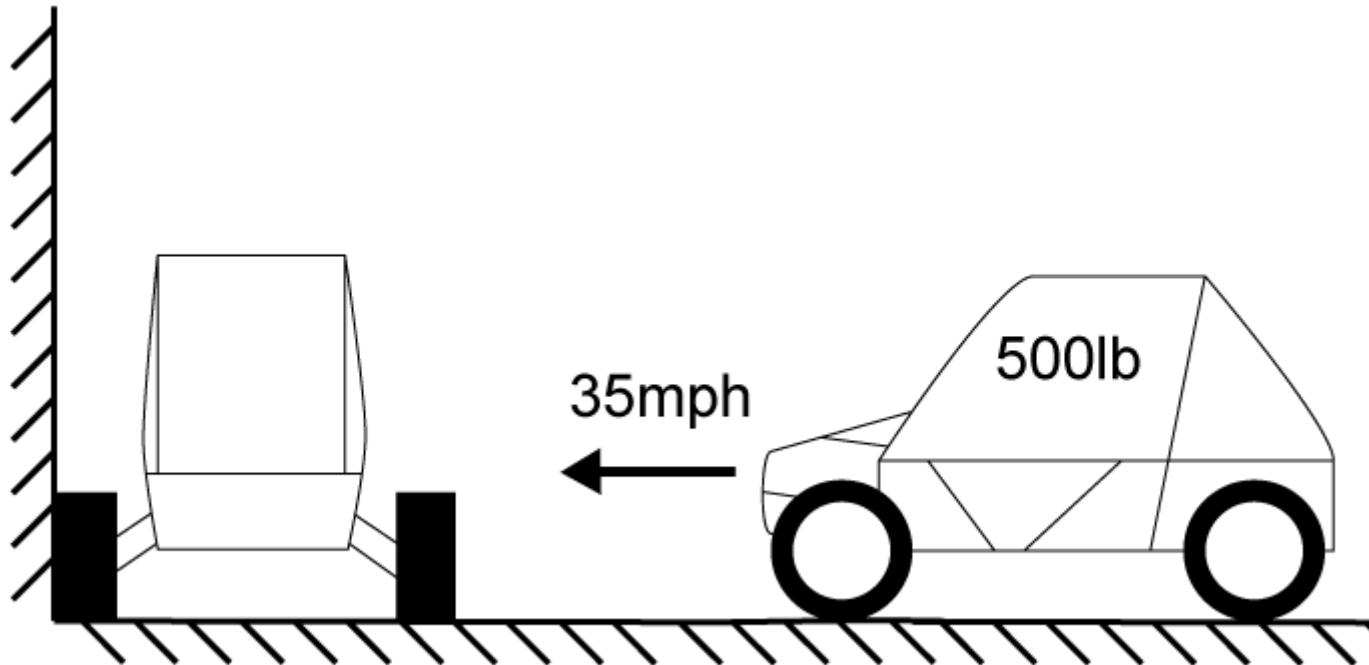

Impact Tests

$$F = m \cdot \frac{V_0}{t}$$

- F = force
- m = mass
- V_0 = initial velocity
- t = impulse time

Analysis Assumptions

- Frame Weight: 100.29 lb
- Drivetrain Weight: 120 lb
- Suspension Weight: 50 lb per corner
- Driver Weight: 250 lb

- AISI 4130 Tubing, 1.25 in Diameter, 0.065 Thickness

Drop Test Safety Factor

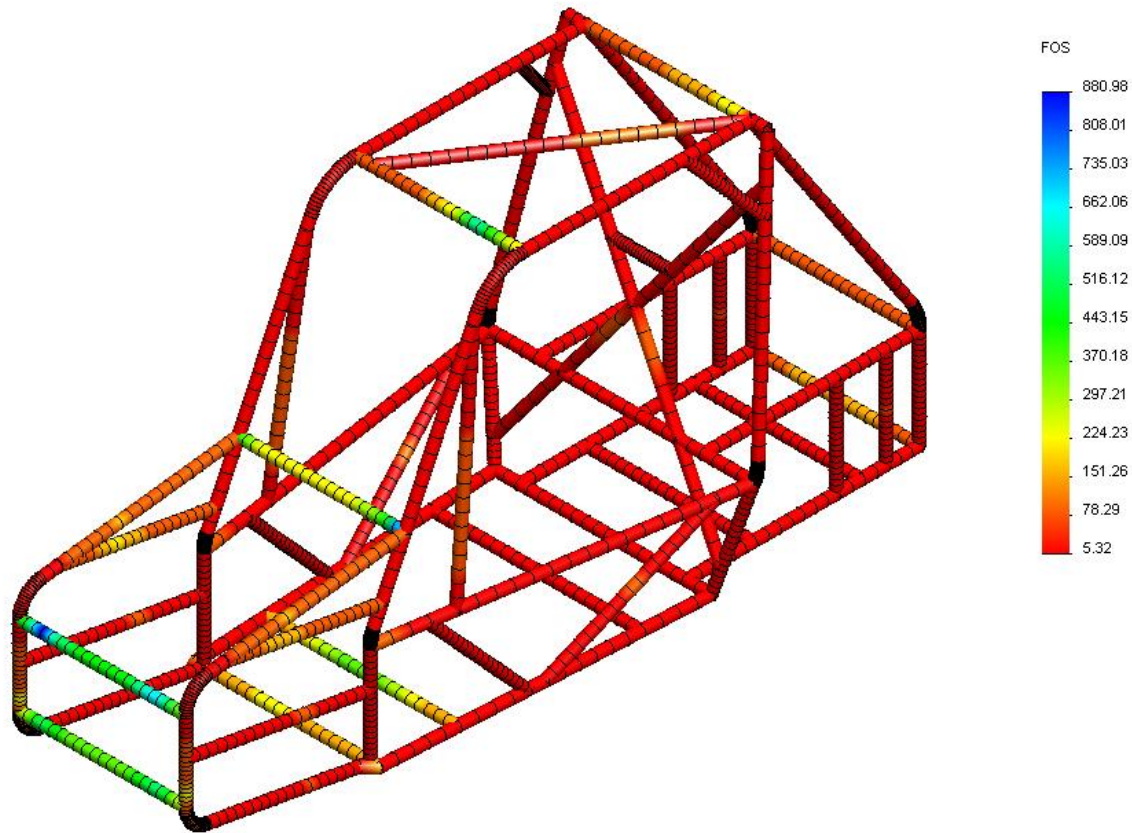

Front Collision Safety Factor

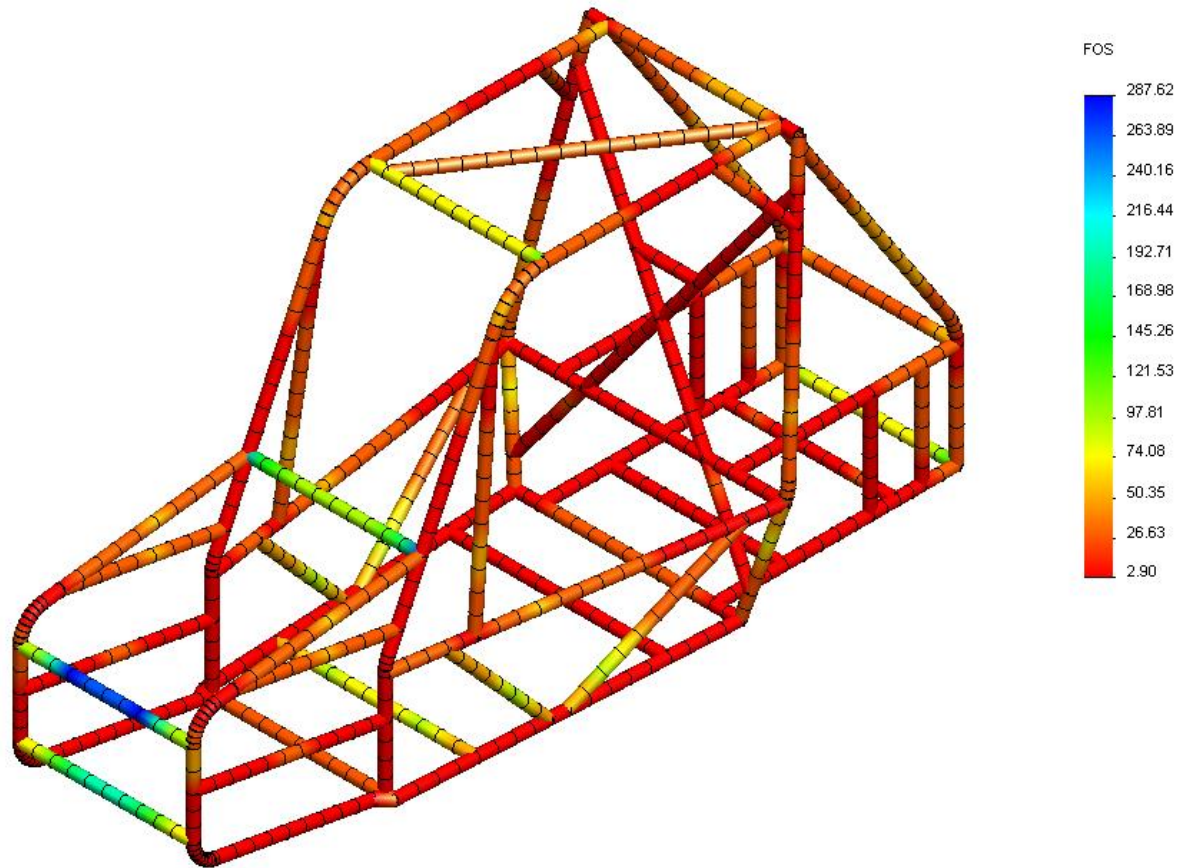

Rear Collision Safety Factor

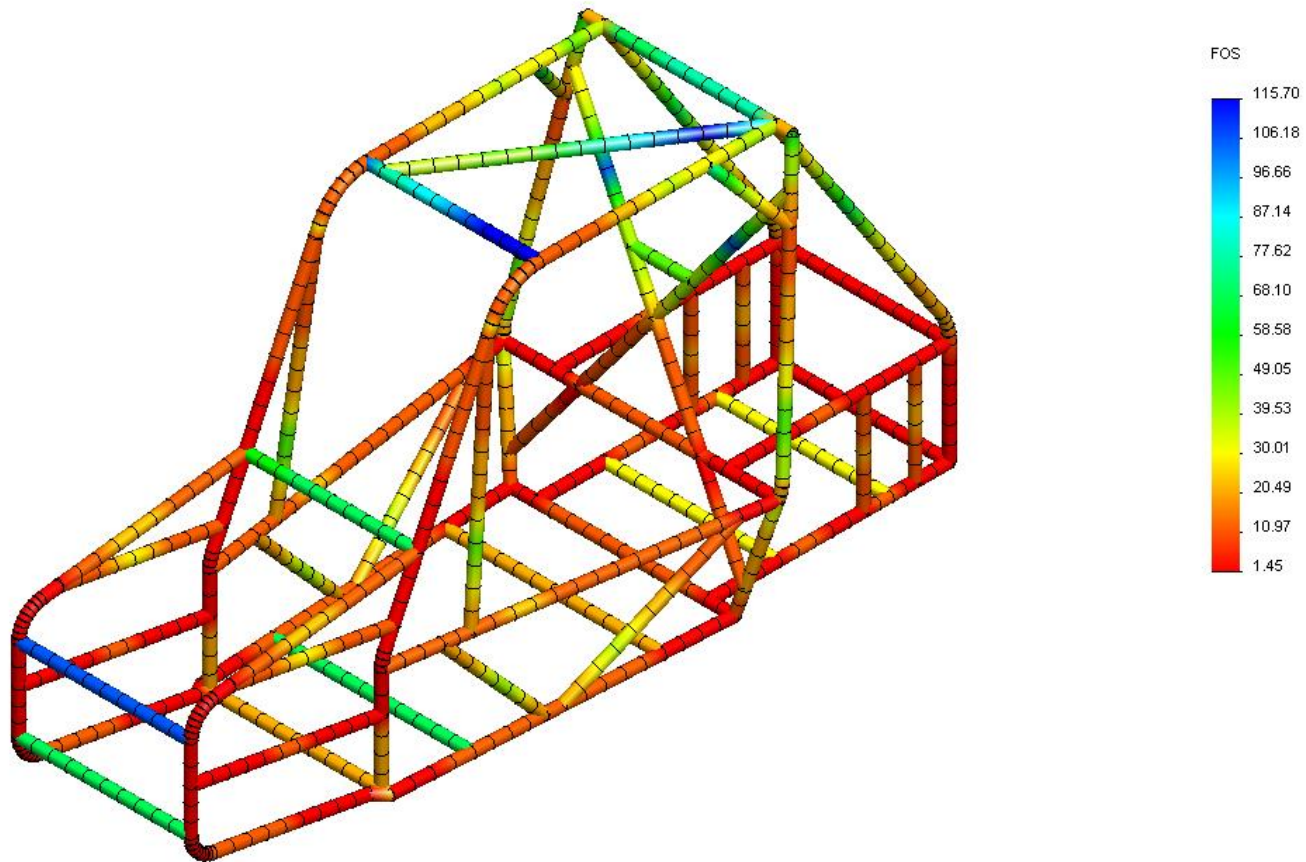

Side Impact Safety Factor

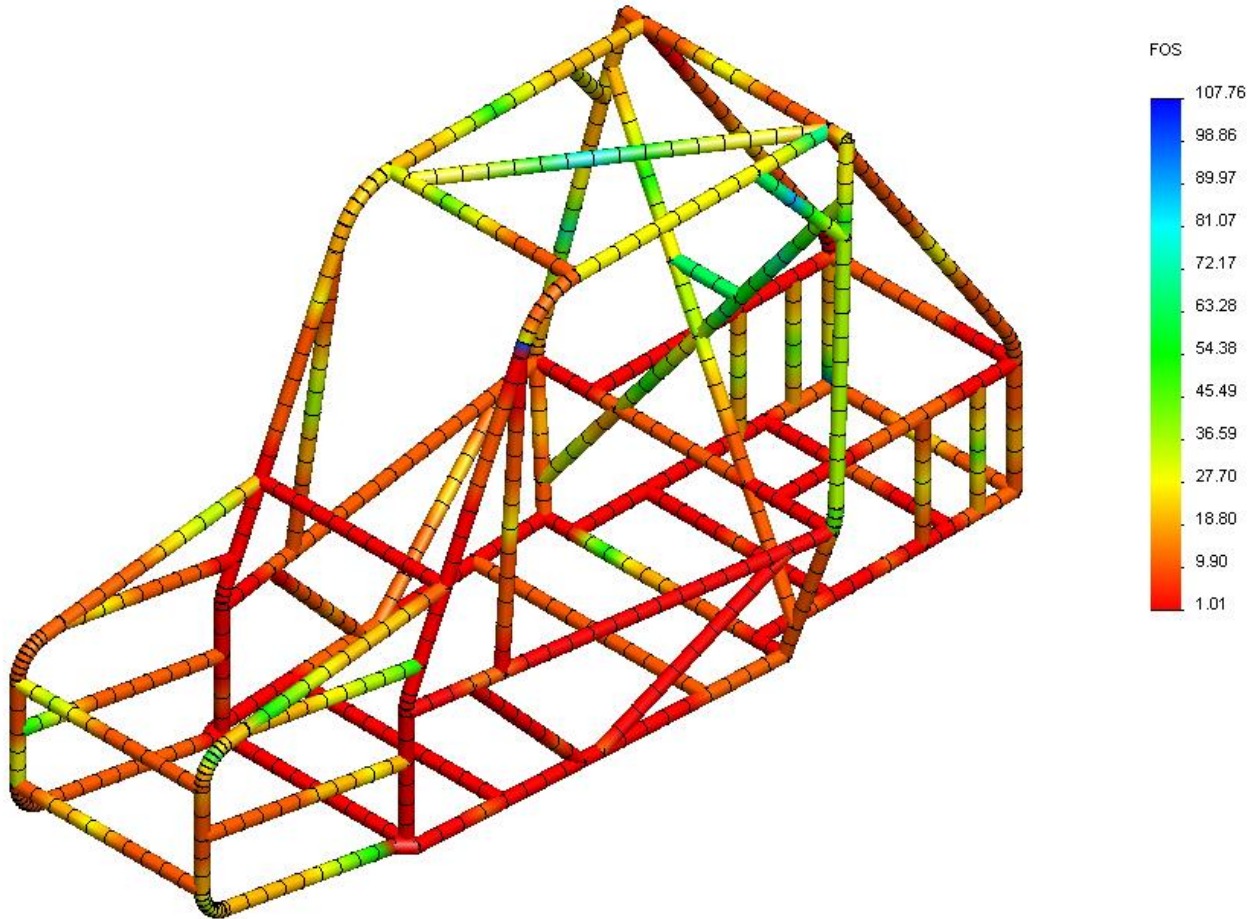

Impact Results Summary

Test	Max Deflection [in]	Yield Safety Factor
Drop	0.089	5.32
Front Collision	0.135	2.90
Rear Collision	0.263	1.45
Side Impact	0.363	1.01

Engineering Design Targets

Requirement	Target	Actual
Length [in]	108	88.18
Width [in]	40	32
Height [in]	41	44.68
Bending Strength [N-m]	395	486.0
Bending Stiffness [N-m ²]	2789	3631
Wall Thickness [in]	0.062	0.065
Pass Safety Rules	TRUE	TRUE

Cost Analysis

- Team Project Budget
- Theoretical Production Cost

Team Project Budget

Item	Amount	Cost
1.25" AISI 4130 Tubing	120 ft	\$200
1" AISI 4130 Tubing	60 ft	\$100
0.375" x 6" AISI 4130 Plate	6 ft	\$112
Corbeau Baja RS Seat	1	\$250
Safety Harness	1	\$75
Kill Switch	1	\$20
Brake Light	1	\$35
Entry Fee	1/3 per team	\$367
Travel Costs	5 people	\$915
Total		\$2074

Theoretical Production Cost

- Production of 4,000 frames per year
- Raw Material
- Off the Shelf Parts
- Labor
- Facilities

Raw Material

Item	Amount	Unit Cost	Cost per Frame	Annual Cost
1.25" AISI 4130 Tubing	80 ft	\$0.85 per ft	\$68	\$272,000
1" AISI 4130 Tubing	45 ft	\$0.85 per ft	\$38	\$152,000
0.375" x 6" AISI 4130 Plate	6 ft	\$55 per 6 ft	\$55	\$220,000
Total			\$161	\$644,000

Off the Shelf Parts

Item	Amount	Unit Cost	Cost per Frame	Annual Cost
Corbeau Baja RS Seat	1	\$125	\$125	\$500,000
Safety Harness	1	\$40	\$40	\$160,000
Kill Switch	2	\$10	\$20	\$80,000
Fire Extinguisher	1	\$15	\$15	\$60,000
Brake Light	1	\$20	\$20	\$80,000
Total			\$220	\$880,000

Labor and Facilities

Item	Amount	Unit Cost	Annual Cost
Metalworkers	4	\$10 per hour	\$80,000
Welders	8	\$15 per hour	\$240,000
Assemblers	2	\$10 per hour	\$40,000
Facilities			\$225,000
Overhead			\$180,000
Total			\$765,000

Total Production Cost

Item	Annual Cost	Cost per Frame
Raw Material	\$644,000	\$161
Off the Shelf Parts	\$880,000	\$220
Labor and Facilities	\$765,000	\$191
Total	\$2,289,000	\$572

Final Frame Design

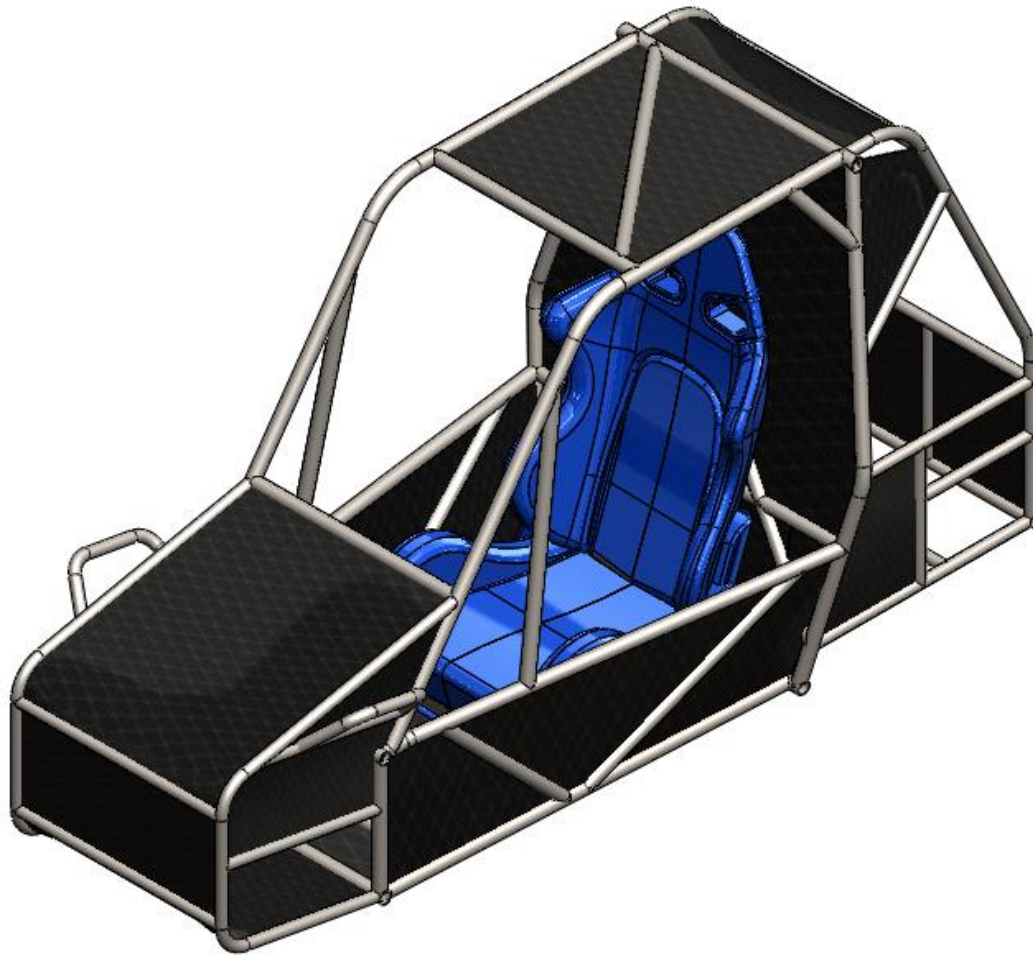

Final Frame Design

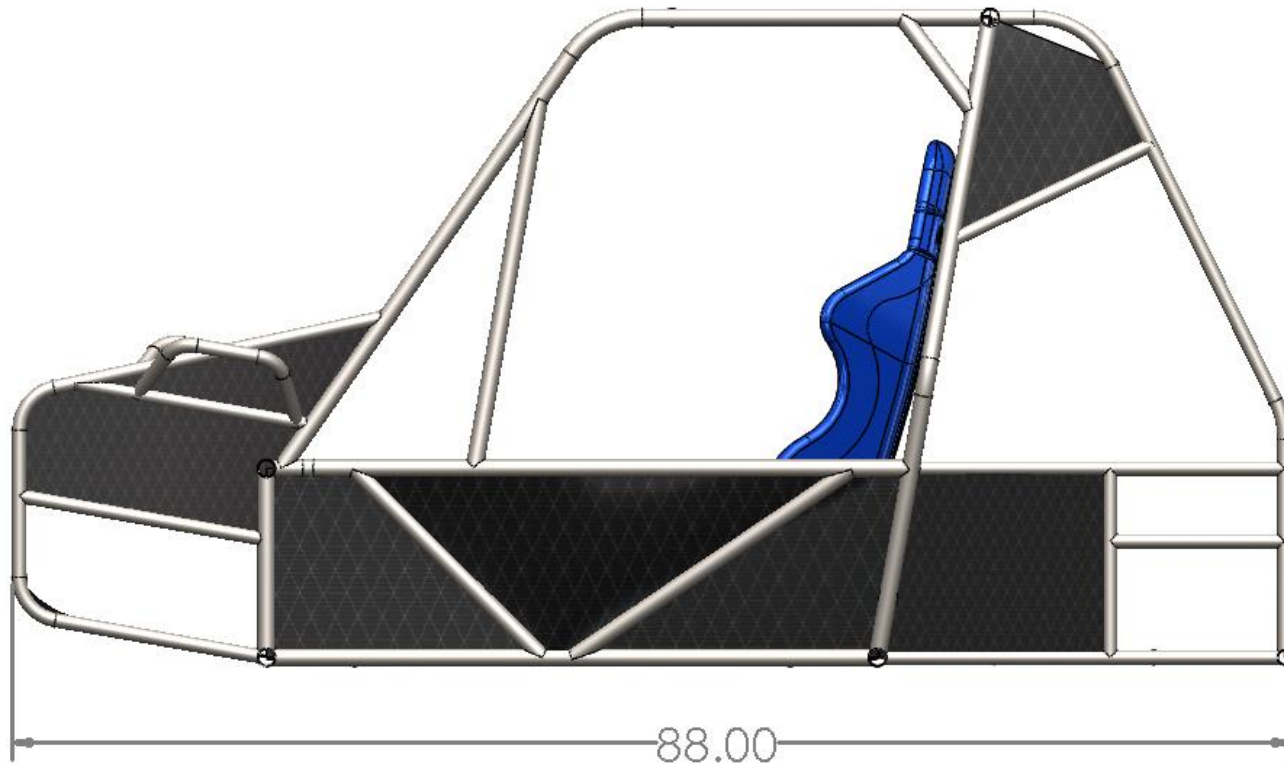

Final Frame Design

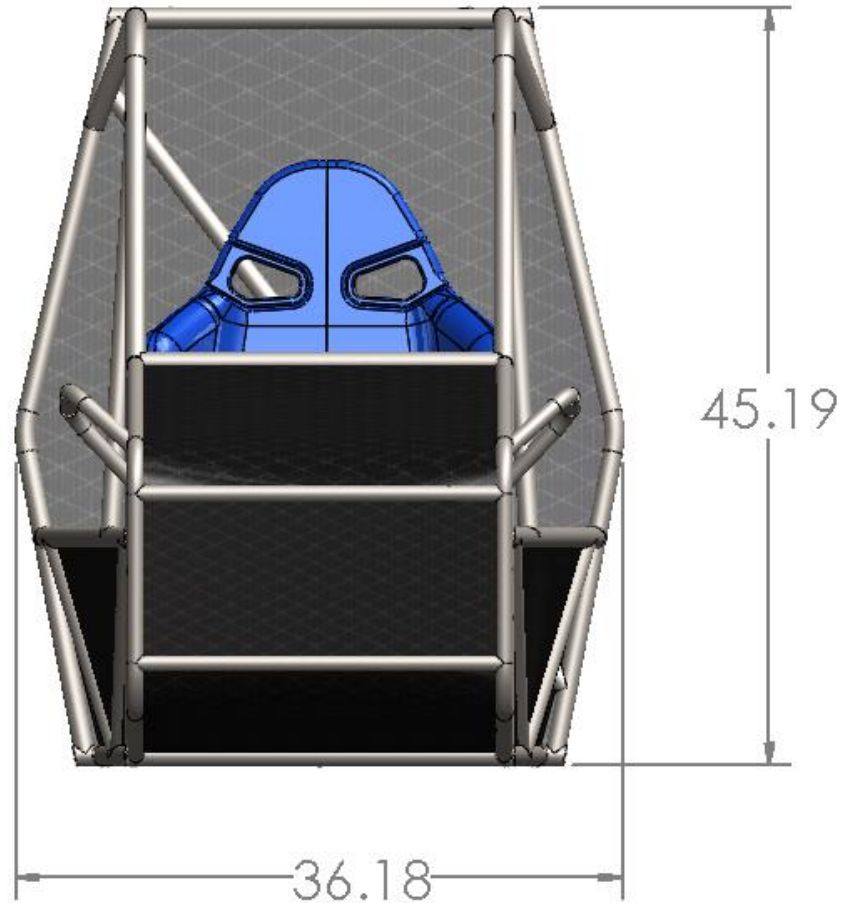

Final Frame Design

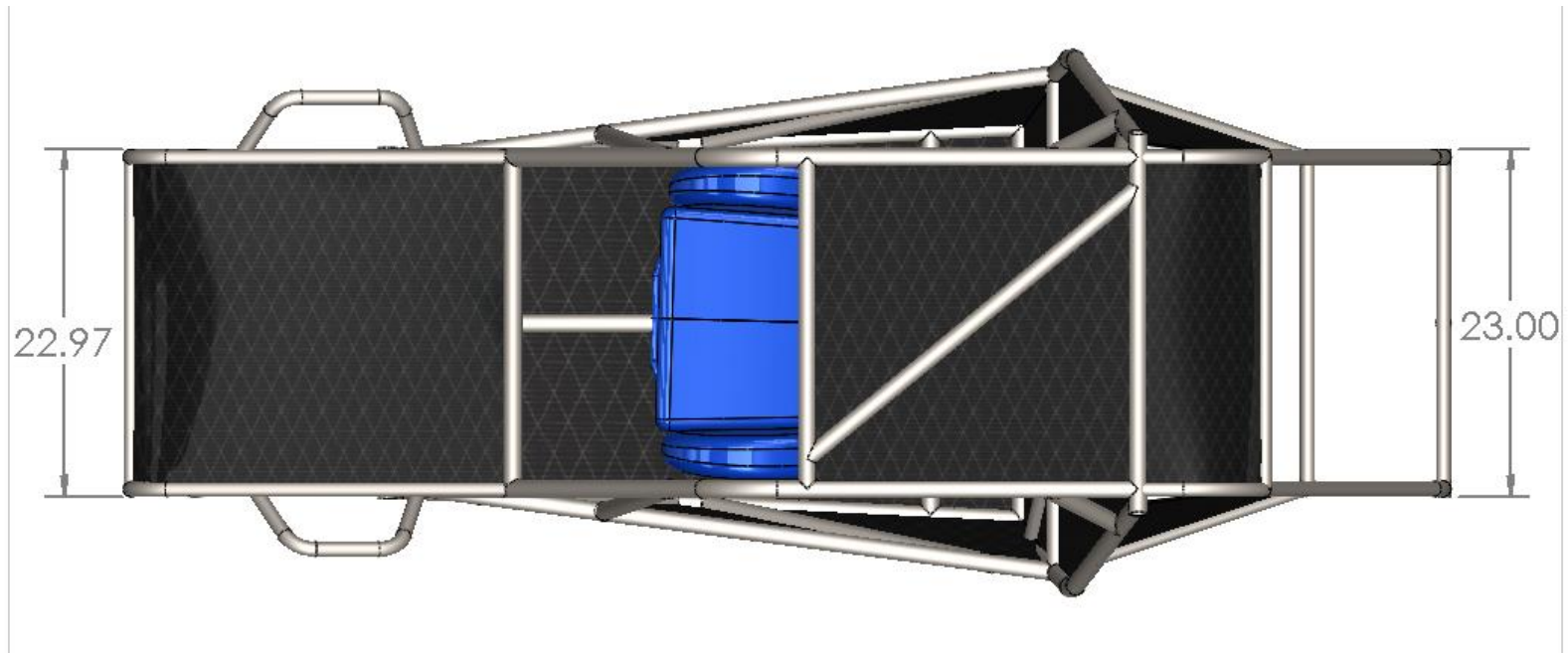

Spring 2014 Project Plan

- Complete Frame by January 31
- Final Assembly by February 24
- SAE Cost Report by March 3
- SAE Design Report by March 20
- Competition on April 24

Spring 2014 Gantt Chart

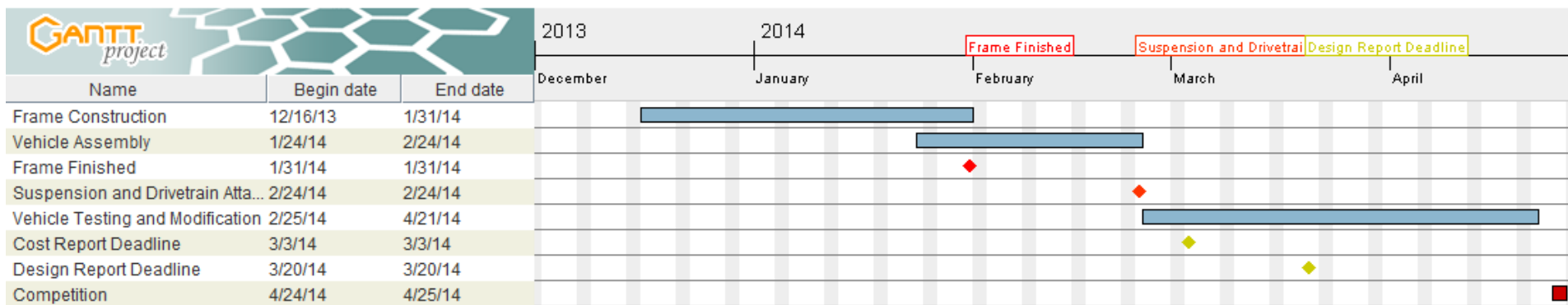

Conclusion

- SAE international is the client, NAU SAE is a stakeholder, and Dr. John Tester is the project advisor.
- Tubing Selection – AISI 4130 steel tubing with 1.25” Diameter and 0.065” Wall Thickness.
27% Lighter than stock tubing
- Four Initial frame designs. The lightest one, Design 2, was chosen.

Conclusion

- Best frame was analyzed. Factor of safety above 1 for all tests.
- Team budget of \$2,074 and an annual production cost of \$2,289,000 for the frame.
- Final frame design based on design 2. Modifications have been made.
- Team finished everything this semester. The frame will be constructed by January 31. The competition is April 24.

References

- NAU Student Chapter of SAE “2006 Mini Baja,” www.cens.nau.edu/~jtt3/Minibaja06, April 2006
- Tester, John T., PhD, Associate Professor Northern Arizona University, personal communication, Sept. 2013.
- SAE International, “2014 Collegiate Design Series Baja SAE Rules,” 2014.

References

- Owens, T., Anthony, Jarmulowicz, D., Marc, Jones, Peter “Structural Considerations of a Baja SAE Frame,” SAE Technical Paper 2006-01-3626, 2006.
- Silva, Martins, Maira, Oliveira, R. P. Leopoldo, Neto, C. Alvaro, Varoto, S. Paulo, “An Experimental Investigation on the Modal Characteristics of an Off-Road Competition,” SAE Technical Paper 2003-01-3689, 2003.
- Tester, John, Northern Arizona University, personal communication, Nov. 2013.

References

- Olsen, Stu, “*Cinders Recreation Area*” 2009, Photograph

Questions?