

# Quick Change Electrical Connection

By

Lauren Campbell, Michael Donelson, Erin Grenko,  
Aaron Hansen and Nick Schafer  
Team 9

## Progress Report Document

*Submitted towards partial fulfillment of the requirements for  
Mechanical Engineering Design – Spring 2013*



Department of Mechanical Engineering  
Northern Arizona University  
Flagstaff, AZ 86011

**Contents**

- 1.0 Introduction..... 3
  - 1.1 Background Research ..... 3
  - 1.2 Needs Identification ..... 3
  - 1.3 Project Goal and Scope of Project ..... 4
  - 1.4 Objectives ..... 4
  - 1.5 Constraints ..... 4
- 2.0 Proposed Design ..... 5
  - 2.1 Description ..... 5
  - 2.2 Dimensions ..... 5
  - 2.3 Material Selection ..... 6
  - 2.4 Cost Analysis ..... 7
- 3.0 Design Changes ..... 7
- 4.0 Current Design ..... 8
- 5.0 Next Steps ..... 10
- 6.0 Gantt Chart..... 10
- 7.0 Conclusion ..... 11
- 8.0 References..... 11

## **1.0 Introduction**

Quick change nose assemblies are used for various applications in today's world. Such designs are currently used for things such as Formula1 and Indy race cars. Yet these designs are purely mechanical connections that simply connect the nose to the desired structure and have no electrical components. In this project, our team wants to bridge this gap and create a design that will allow for electronics to be connected as well. This connection would allow our client to mechanically attach a nose assembly to the body of a structure without having to worry if the electrical components are attached correctly, because our design should insure that this happens. This connection should be able to withstand the operating conditions of the structure and provide proper electrical performance through its entire use.

This report will discuss a few of the problems our team has run into and the ways the team has decided to fix those problems. Previously, the team decided an adhesive would be used to connect the added piece to each part of the missile, but that idea was not valid, so instead our team is working on a different way to attach the extra piece to the missile body and nose cone.

### **1.1 Background Research**

Our client for the Quick Change Electrical Connection (QCEC) is Raytheon Missile Systems. Raytheon is the world leader in design, development and production of missile systems. The company was started over 90 years ago, originally producing household items. During World War II, Raytheon came up an electron tube that could detect enemy aircraft and ships. Raytheon also made the computer that allowed Apollo 11 to be the first successful moon landing. Since then, Raytheon has expanded out into missile production which allowed them to create a branch just for defense contracting, Raytheon Missile Systems.

### **1.2 Needs Identification**

The current electrical connection design for the missile system by Raytheon does not allow for a simple and effective connection between the nose and body of the missile. As the design stands, the electrical connection must be manually connected, which both is inefficient and does not assure that the connection is properly made. This also requires two individuals to work together on the assembly – one to connect the electrical connection while the other holds the nose until the connection is made.

### 1.3 Project Goal and Scope of Project

Raytheon desires an assembly of the missile nose to the body with only one individual and assurance that the electrical connection is secure between the two components. To do so, the connection must be self-aligning, endure numerous environmental factors without failing, and must not disconnect during use or otherwise compromise the functioning of the missile. The design of the connection is limited solely to a given volume on the bottom inner area of the nose and body of the missile and not the physical connection of the two components of the missile.

### 1.4 Objectives

The objectives of the QCEC project that the team is trying to accomplish are to make the connection and its zone as cheap as possible, to make the connection last as long as possible before failing, to make the connection easily replaceable or repaired, and to make sure the area is within the approved dimensions. The point of making the connector and its zone inexpensive is to make sure that when it is mass-produced that it doesn't end up costing Raytheon a lot of money. Although the long life may not be as big of a concern since missiles are not reused, they are mass-produced and do tend to sit around for a while beforehand. Making sure the part is easy to replace if it cannot be repaired is also necessary so that a small amount of time is used up changing out the nose cone if needed. The objectives along with their basis of measurement and units used in these measurements can be found below in table 1.

**Table 1: Objectives**

Objective	Basis of Measurement	Units
Inexpensive	Cost of producing 200 per year	\$
Long Life	Time before failure	Years
Field Replaceable	Time taken to replace	Minutes
Easily Repaired	Distance part is deformed	Inches
Size	Area we have to work with	Inches

### 1.5 Constraints

Raytheon has a specific set of criteria for the Quick Change Electrical Connection to meet in order to function properly. The constraints include operation at:

- A temperature range of -34 to 51 °C

- Sand particle size between 47.7 and 645 micrometers at a concentration of .684 gram/m<sup>3</sup> at a velocity of 25mph
- Dust less than 96 micrometers in size at a concentration of  $6.84 \pm 3$  grams/m<sup>3</sup> at a velocity of 25mph
- Water and ice at 0.7 inches per hour at a velocity of 556 feet per second and with an average droplet size of .045 inches with no failure during icing conditions
- Corrosion resistance to a salt solution with a 3% atmospheric salt solution
- Transportation loads of 19 G's of force
- Bomb rack ejection shock of 32 G's of force
- No material reaction in the presence of JP-10 jet fuel in both its vapor and liquid forms

Physical constraints are also a major factor given by Raytheon. The volume that the connection can be within is 1" by 2.5" by 1.25", which is shared between the nose and body of the missile. Additionally, the connection must make the mating tolerance in order to ensure the connection is made successfully without any doubt and does not affect the physical connection of the two components. The components must have a warranty of 15 years and a service life of 20 years. The overall cost should not exceed \$1,000, be field replaceable, and take into account support issues that ensure damage to hardware can easily be repaired.

## **2.0 Proposed Design**

Our final design proposal is the solid guided design based on our engineering analysis and our concept selection.

### **2.1 Description**

The solid guided design as previously stated is a self-aligning mechanism which allows the electrical connector to mate within the specified tolerance. This allows for any misalignment between the nose and body to still create a good bond between the two electrical pieces. A gasket allows for a tight seal to block any outside contaminants.

### **2.2 Dimensions**

In figure 9 below, there are the proposed dimensions to meet the requirements stated above.

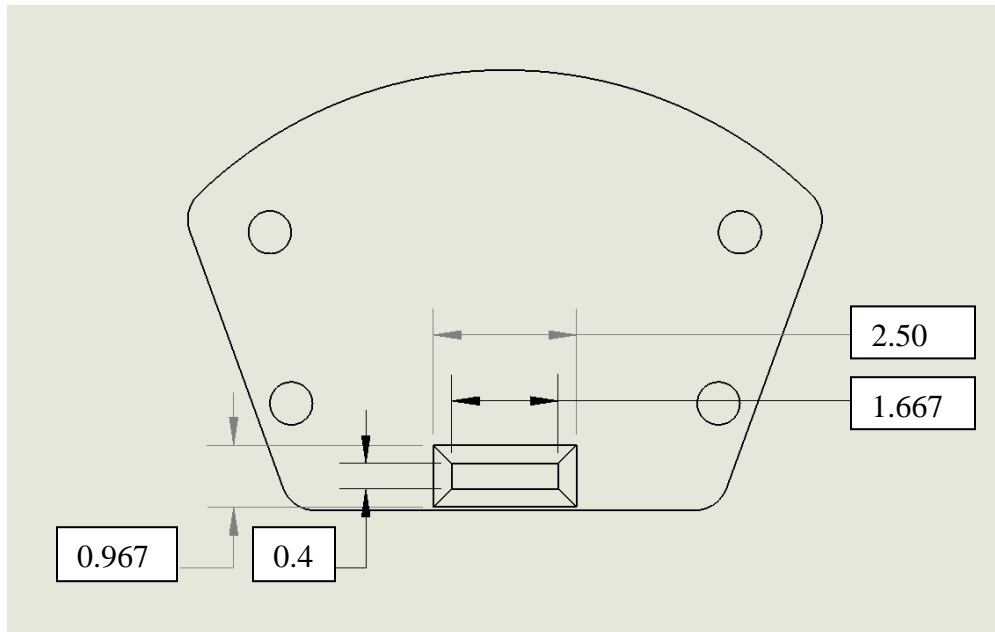

**Figure 1 – Final Proposal Dimensions**

### **2.3 Material Selection**

The focus for evaluating the materials used in our concepts will be the specified operating conditions that were previously discussed. These are the most important because if the developed design cannot meet all of the given criteria, then it will be considered to have failed. Based upon the different conditions that the design must operate under, the team has comprised a list of material properties that will allow for the final design to withstand these conditions. This list of properties includes:

- Have a low thermal conductivity
- Be corrosion/rust resistant
- High ductility
- High hardness
- High tensile strength

The material we have chosen is AISI 303 Stainless Steel. This is due to its unique properties that make it optimum for the specified operating conditions. This type of steel is less brittle at low temperatures with a modulus of elasticity of 27.6 Mpsi. It also will withstand the forces on the

system with a yield strength of 35 kpsi and ultimate strength of 87.3 kpsi. This material is resistant to corrosion and is able to operate in the temperature conditions.

### 2.4 Cost Analysis

The cost analysis is split up into two sections, what it would cost our team to prototype the design and our predicted cost for manufacturing at Raytheon.

**Table 2: Cost of Prototyping**

Category	Units	Cost
<b>Material</b>	\$3-6 kg	\$7.20
<b>Manufacturing</b>	Free (Machine Shop)	
<b>Electrical Connector</b>	\$20 per unit	\$20
<b>Totals</b>		\$27.20

The estimated cost for Raytheon was calculated below, in table 7, for one unit.

**Table 3: Estimated Cost Analysis**

Category	Units	Cost
<b>Material</b>	\$3-6 kg	\$7.20
<b>Manufacturing</b>	Man Hours	4 hours ~ \$80
<b>Production Cost</b>	Man Hours	2 hours ~ \$40
<b>Electrical Connector</b>	Glenair Unit Price	\$40
<b>Totals</b>		<b>\$167.20</b>

This shows the estimated unit cost is under the desired cost as specified per Raytheon's request. This allows for some of the budget to be left for any repairs if needed.

### 3.0 Design Changes

After discussing our final design with Raytheon, our contact gave us some suggestions to improve our design. First our material was approved so we can start obtaining materials for our

prototype. We were also told that for our design to be field replaceable we could not use adhesive to secure our electrical connector or design to the body of the missile. However, we can use the tin plate located above our specified section to drill into. When working with the tin plate we cannot go past the depth of our zone, and we cannot cut the thin layer between our section and the tin plate this is because it is a part of the missile body . This is shown in figure 2 below.

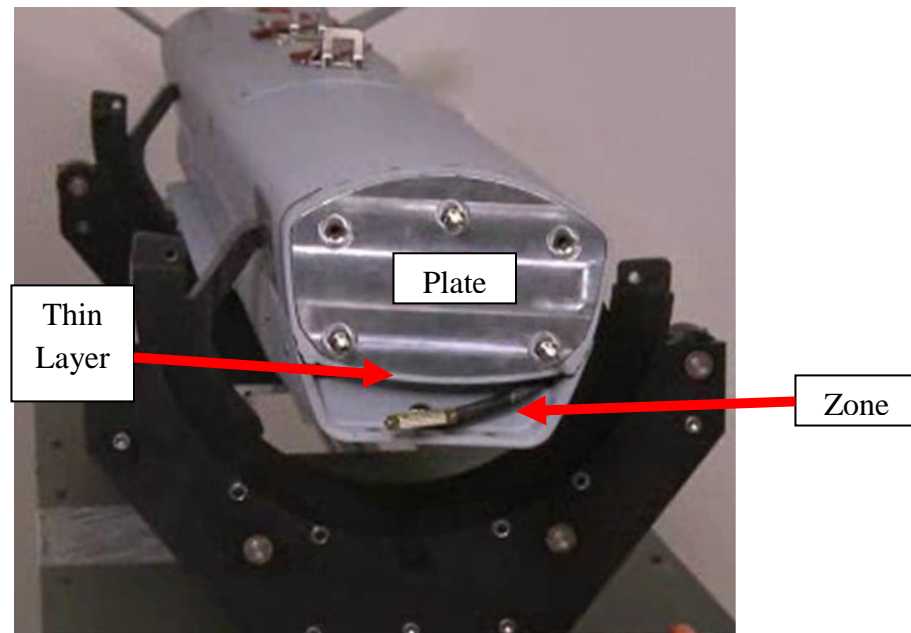

**Figure 3 - Inside of Missile**

The next revision is we must pay attention to the preload required to connect the two electrical connectors. The two connectors should mate with 40lbs of force and one person should be able to put it together. Our contact suggests that we look into how tolerances can affect how the two sections mate. Ultimately if our design requires enough force that two people have to put it together, than we have not met the requirements.

#### **4.0 Current Design**

The updated design is no longer a part of the missile body instead, the design uses a rectangular insert. This rectangular insert contains the previously slanted edges that insure the electrical connection is aligned properly. Furthermore, the design has a hollow inside to allow for the electrical connector to make contact with the missile head. However, in order to fix the design to the missile body flat head screws will be used in conjunction with a metal flange attached to the



top of the rectangular insert. This flange will then be fastened to the tin plate above the area of use. This will insure a stable operation for both the electrical connector and the alignment. Our new design is shown below in figures 4, 5, and 6.

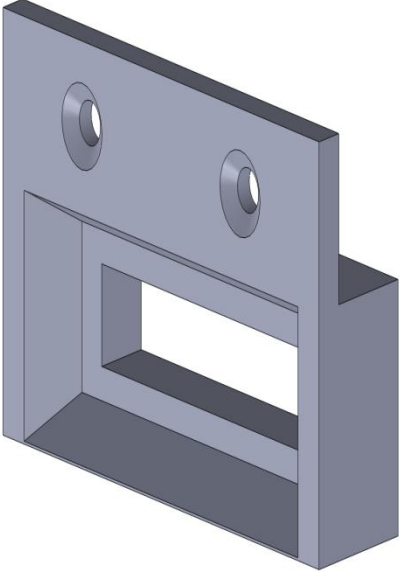

**Figure 4 - Back View of Design**

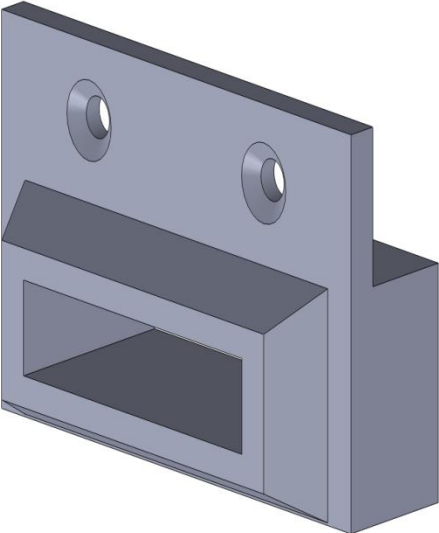

**Figure 5 - Front View of design**

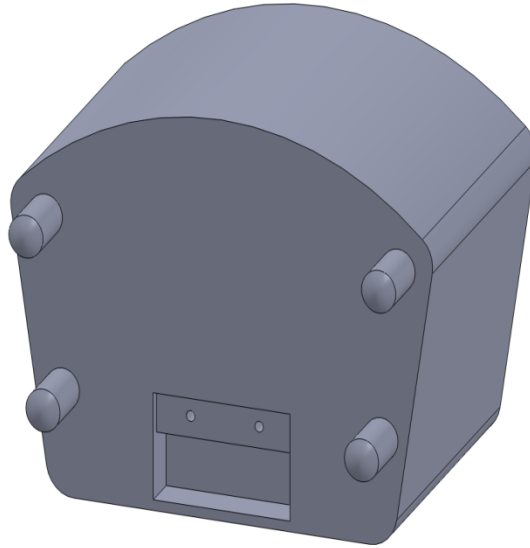

**Figure 6 - Screw Placement**

## **5.0 Next Steps**

From here the design team is going to propose the previous idea to Raytheon for approval. If there are no problems with the design and Raytheon approves of the screws and attachment method. The design team will then proceed to fully complete the fixture process for the electrical connector and they proceed to prototyping. The main goal for prototyping is that the missile body can be made of a plastic composite to ease the manufacturing process. However, if there are complication in the mechanics of the design while using plastics this will not work. After a prototype is completed and machined. The design team will begin testing the prototype to insure in meets all stress, corrosion, and lifespan requirements from Raytheon. The last and final step will be to perform calculation to confirm results and compile the information into a presentation.

## **6.0 Gantt Chart**

Following the next steps the team will be taking over the next several months to produce a prototype product for Raytheon, Figure 7 below shows the timeline for which the team will follow through to assure the prototype is created in a timely manner. The team has already completed the necessary changes to the design that were cause for concern by Raytheon, and a solution to address all concerns has been developed, both shown in red on the chart. From here, the team will now resubmit the redesigned concept to Raytheon and, ideally, receive a response from them by February 6<sup>th</sup>, a key date in the team's schedule.

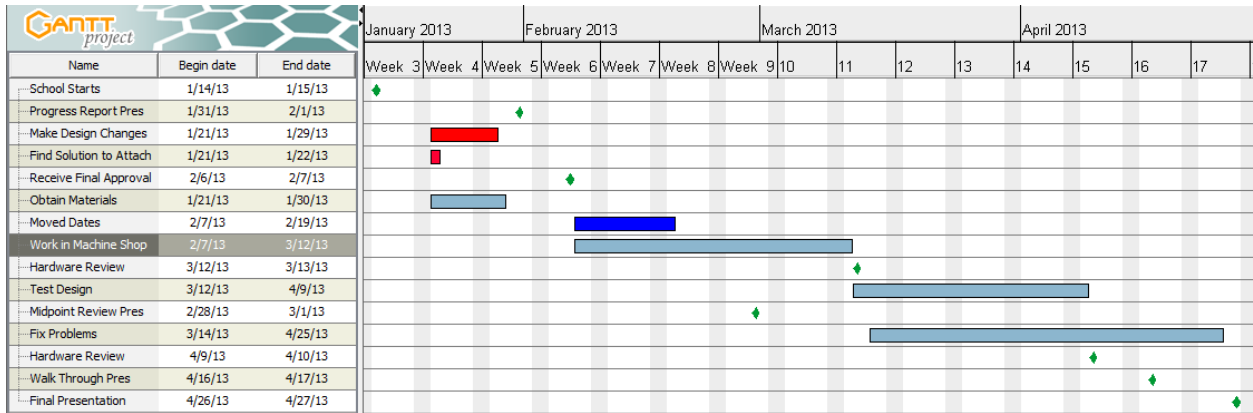

**Figure 7** - Gantt chart demonstrating the team’s plan to produce a working prototype this semester.

Upon acceptance of the new design, the team will then begin the obtaining of materials and subsequent work in the Machine Shop at NAU to begin building the prototype connector. This is dependent upon the approval of the new design occurring by the 6<sup>th</sup> of February, as noted prior. This delay is the reason why the “Obtain Materials” selection, shown in dark blue in Figure 7, has been shifted from between January 21 and January 30, to the new dates of February 7 through 19. The remainder of the semester is straightforward with scheduling, which includes an estimated start date to begin testing the design by March 12 and begin addressing any problems with the design a couple days later on March 14 as the design is tested, and continue fixing the design through to the end of April as necessary, in time for the final presentation on April 26.

## 7.0 Conclusion

In conclusion, this document has addressed the problem statement of the missile electrical connection issue provided by Raytheon and restated the status of the project as of the end of last semester. Upon Raytheon’s review of the proposed design and list of concerns about that design, the team has identified the revisions needed to the design and updated the design to address these concerns. Finally, the team has explained the next courses of action that will take place over the next few months. Due to the concerns voiced by Raytheon, and subsequent redesign of the connection, the team is slightly behind schedule at this point in the semester, but has no concerns that the building, testing, and fixing phases of the project will be impacted by this small setback, and that a full prototype will be ready by the end of the semester.

## 8.0 References

- [1]. Shackelford JF, 2009, *Introduction to Material Science 7<sup>th</sup> Edition*, Pearson Prentice Hall.
- [2]. Budynas RG, Nisbett JK, 2011, *Shigley’s Mechanical Engineering Design 9<sup>th</sup> Edition*, McGraw Hill.

[3]. Larimore S, Bliss S, Morzinski M, and Concilio A, 2012, "2012-2013 University Design Project: Quick Change Electrical Connect Project Package," Revision A, Raytheon Missile Systems. Raytheon official website. Web. 3 December