

ALMC

Abdulelah Lazim Mohamed Converter (ALMC)

Client:PhD.VenkataYaramasu,E-mail:Venkata.Yaramasu@nau.edu,Phone:+1-928-523-6092.

GTA: Mr. Jason Foster, E-mail: jf727@nau.edu, Phone: +1-928-310-5557.

Team Leader: Mohamed Aldihani, E-mail: mra275@nau.edu, Phone:+1-928-637-3765.

Lazim Almutairi, E-mail: laa299@nau.edu, Phone:+1-619-909-2936.

Abdulelah Alajlan, E-mail: aaa2275@nau.edu, Phone:+1-530-965-373.

Matlab: Simulation to NPC converter

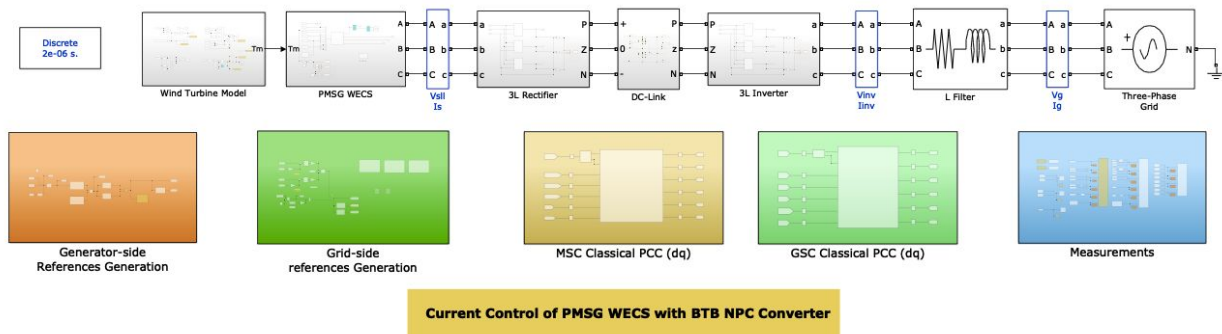

Fig. 1. Simulation NPC Converter for Wind Turbines.

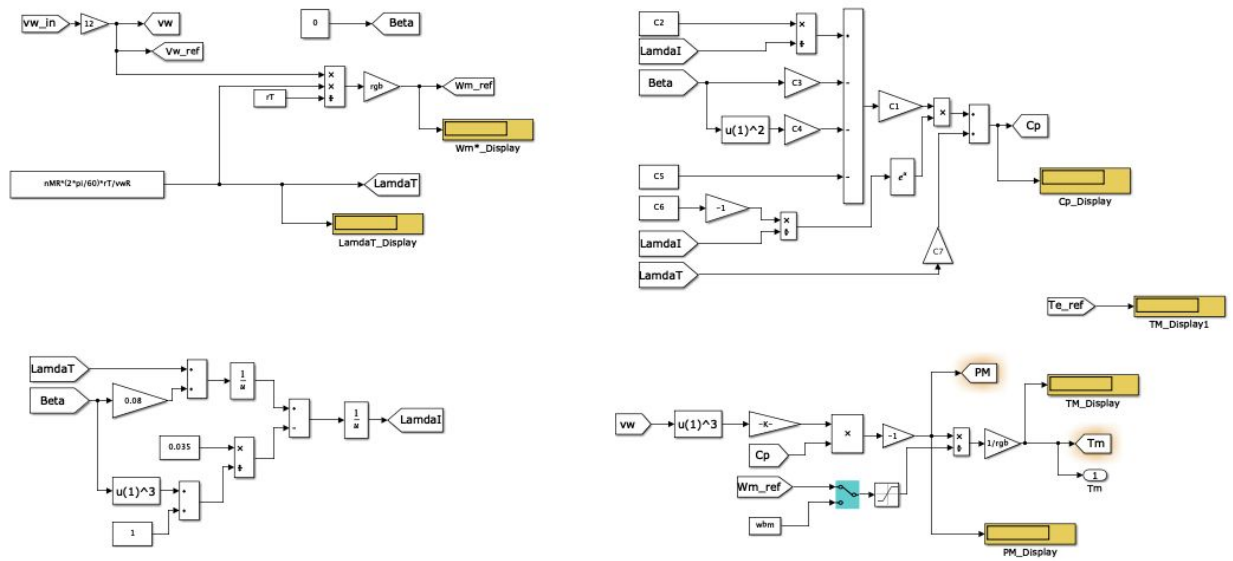

Fig. 2. Simulation (wind) NPC Converter for Wind Turbines.

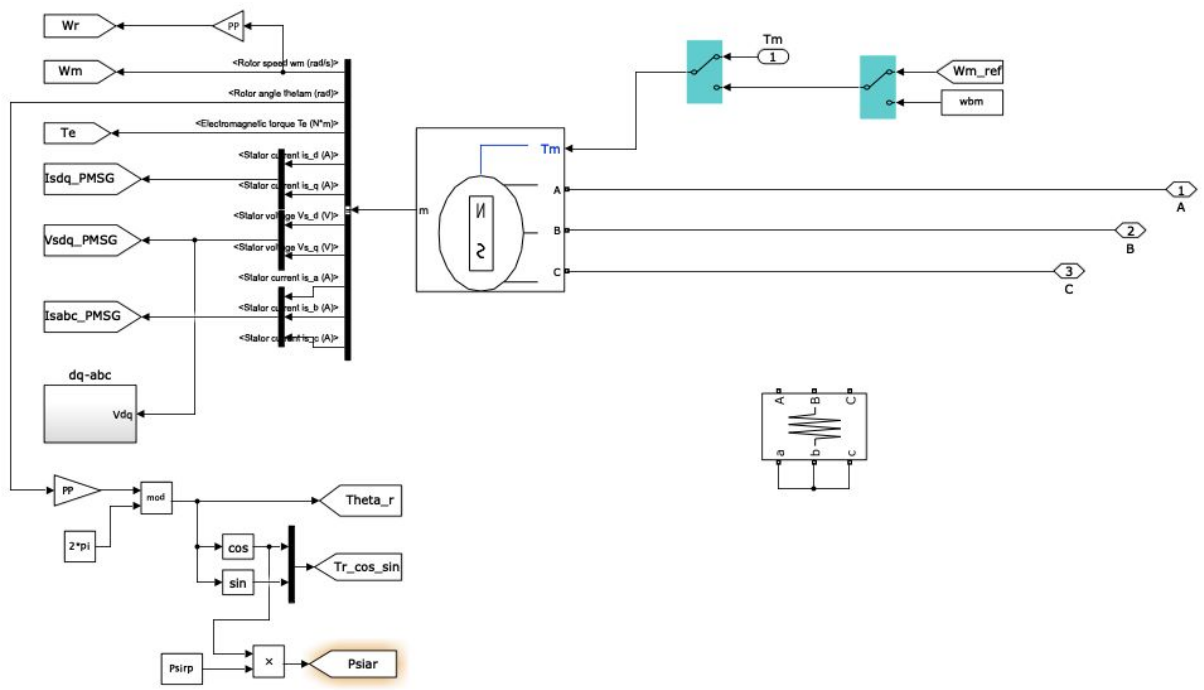

Fig. 3. Simulation (Motor) NPC Converter for Wind Turbines.

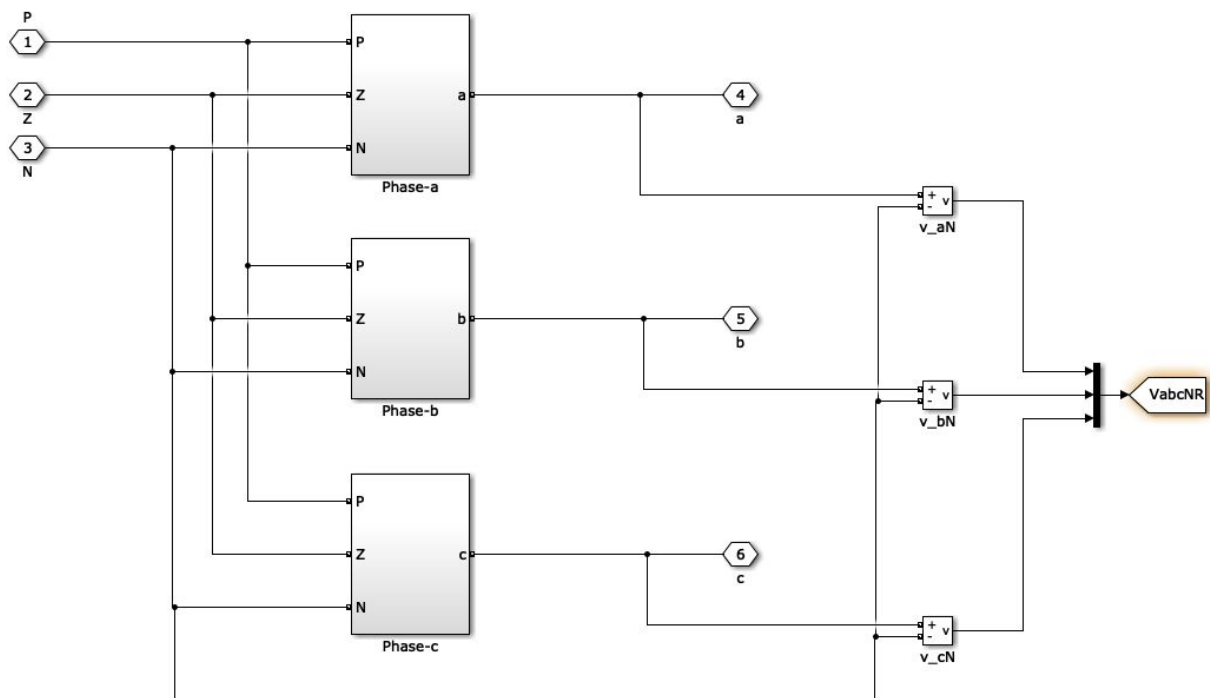

Fig. 4. Simulation (3L Rectifier) NPC Converter for Wind Turbines.

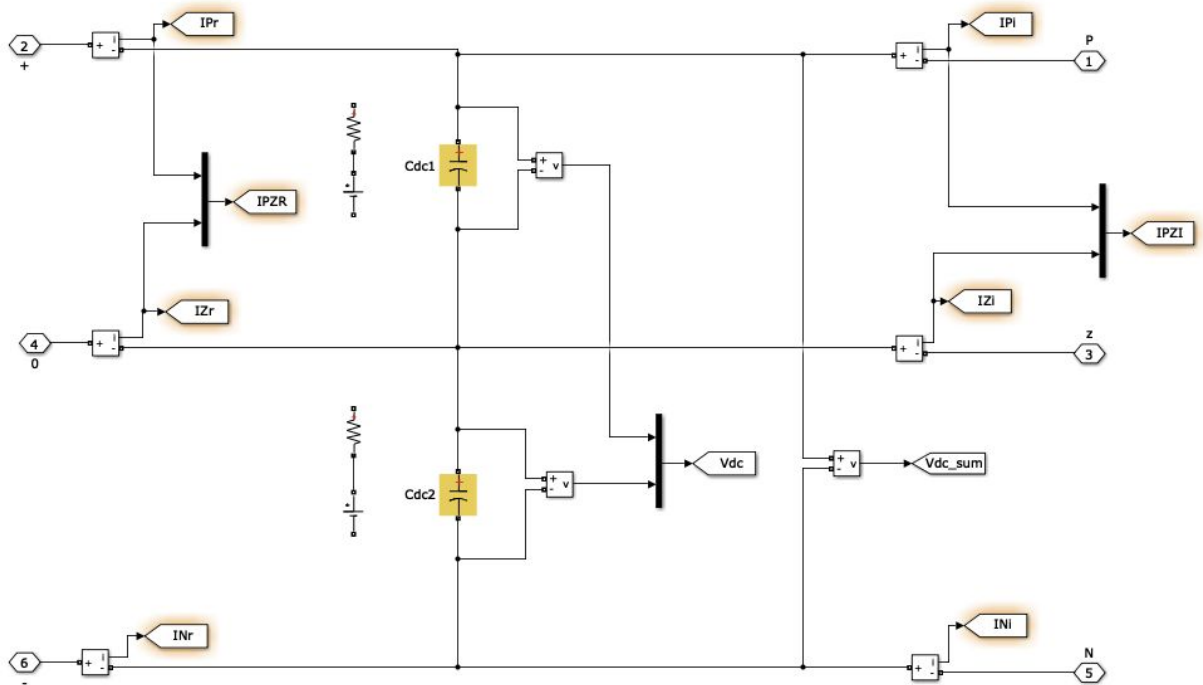

Fig. 5. Simulation (DC-Link) NPC Converter for Wind Turbines.

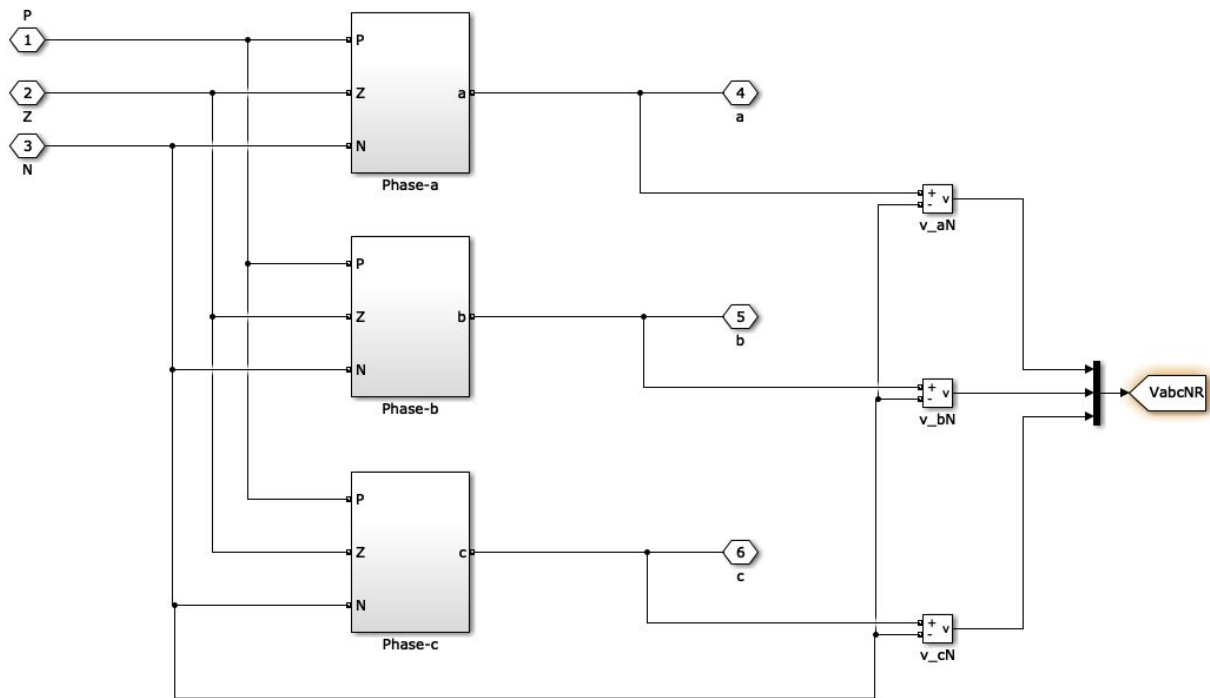

Fig. 6. Simulation (3L Inverter) NPC Converter for Wind Turbines.

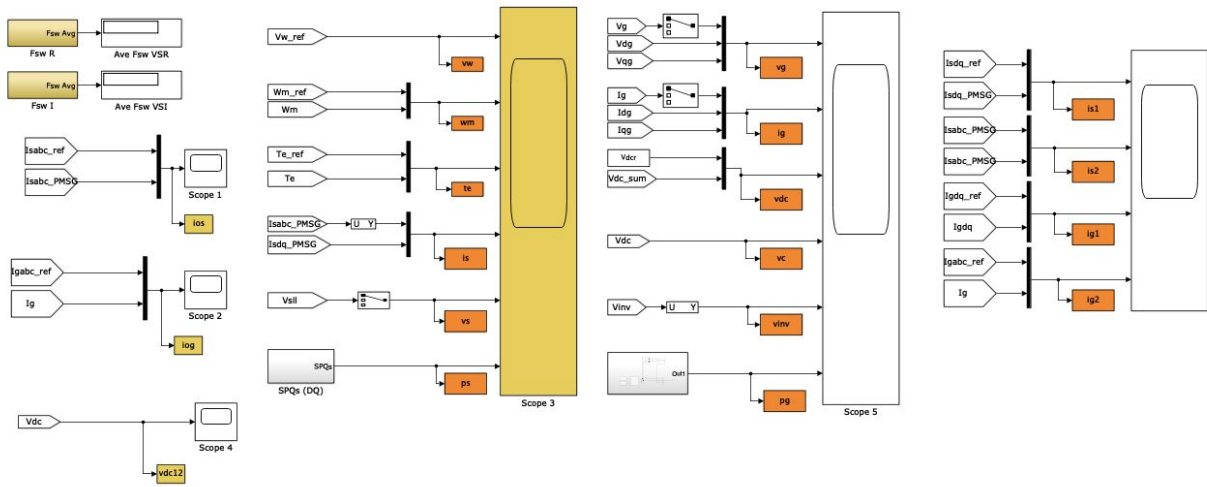

Fig. 7. Simulation (3L Inverter) NPC Converter for Wind Turbines.