

# COLLEGIATE WIND COMPETITION 2020: ELECTRICAL SUB-TEAMS

Humoud Abulmalek† [ha434@nau.edu](mailto:ha434@nau.edu), Mohammed Almutairi† [mma559@nau.edu](mailto:mma559@nau.edu), Calum Eikenberry†† [cje223@nau.edu](mailto:cje223@nau.edu),

Nigel Grey† [ng474@nau.edu](mailto:ng474@nau.edu), Carlos Najera†† [crn82@nau.edu](mailto:crn82@nau.edu), Nicholas Wurtz†† [naw94@nau.edu](mailto:naw94@nau.edu)

†DC-DC Converter Sub-Team  
 ††Auxiliary Sub-Team

## Abstract

In response to the Department of Energy (DOE) and National Renewable Energy Laboratory's (NREL) annual Collegiate Wind Competition (CWC), our Capstone project is to design an AC-DC and DC-DC converter system within a micro-scale wind turbine. Our final product is an integral system within a model of effective and reliable non-grid-connected wind power generation.

Wind energy systems are one of the most appealing renewable energy technologies leading the way into a less fossil-fuel dependent world. Our project promotes the optimization of current wind energy turbine systems by reducing the overall voltage drop and subsequent power loss over the system as a whole.

## Background

To generate interest and identify qualified prospective workers to join the U.S. power generation workforce, DOE and NREL created the CWC in 2014. Wind energy systems are one of the most prominent sources of renewable energy, and are currently reaching 760G watts of global power capacity [1]. Since wind turbines have been converting the kinetic energy of the wind into electrical energy since 1887 [1], there was much prior art to inform our design of this year's micro-scale wind turbine.

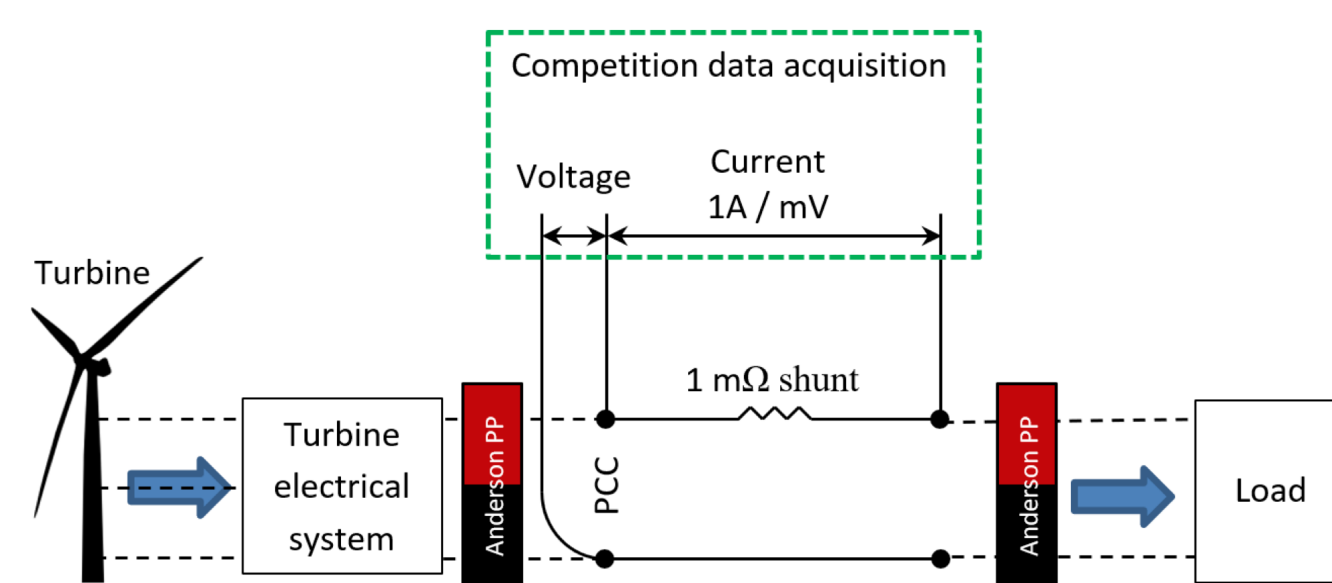

Fig. 1: Competition Overview[2]

Apart from NREL aiming to ensure the availability of reliable energy in the country, it's aspiration is to guarantee a clean environment by promoting the adoption of renewable energy. **Our project aligns with NREL's goal, with the potential of developing new optimization strategies to advance the technology one the most appealing renewable energy sources—wind power.**

The block diagram (Fig. 1.) provided by the CWC provides an overview of the competition setup; the *Turbine electrical system* and *Load* were the responsibilities of our teams albeit with some caveats due to Corona virus.

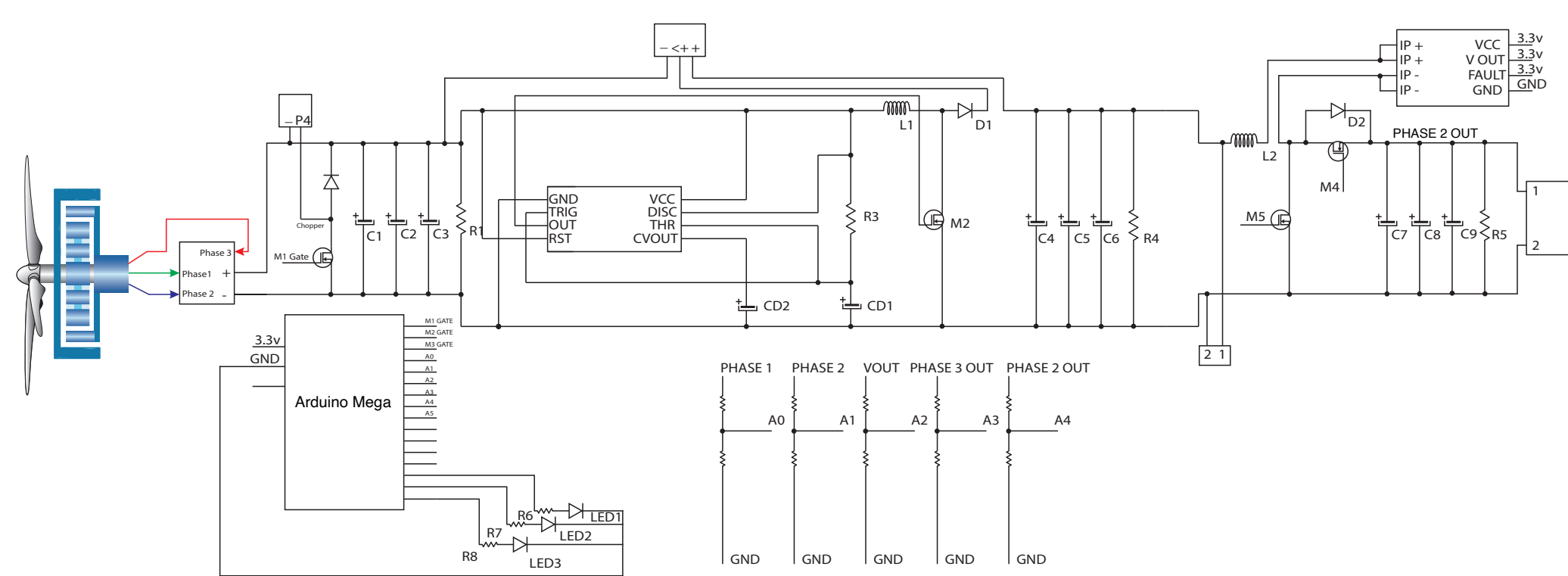

Fig. 2: Schematic

## Objective & Results

The DC-DC team chose to use a synchronous boost converter topology—where two MOSFETs are used, rather than a MOSFET and a diode. In addition, our design (Fig. 2.) includes two boost converters in series, with an optional third converter, to increase power generation at very low cut-in wind speed. This design, along with proportional integral (PI) control at the final boost converter stage, has the effect of keeping the output voltage across the *Load* (see Fig. 4. for 10V output with a  $V_{in}$  of 3V), as constant as possible, in addition to minimizing power loss at low wind speeds.

The DC-DC team leveraged Simulink to model, tune, and flash the PI-controlled boost converter (Fig. 3.) to a physical microcontroller. After mapping  $V_{in}$ ,  $V_{out}$ , and  $[Pulse]$  to the Arduino Mega microcontroller pins, the PI block from Fig. 3. was exported successfully. In utilizing Simulink's Arduino export tool, our team was able to program all control modules to run in parallel including: braking, voltage measurements, current measurement, and PI controller.

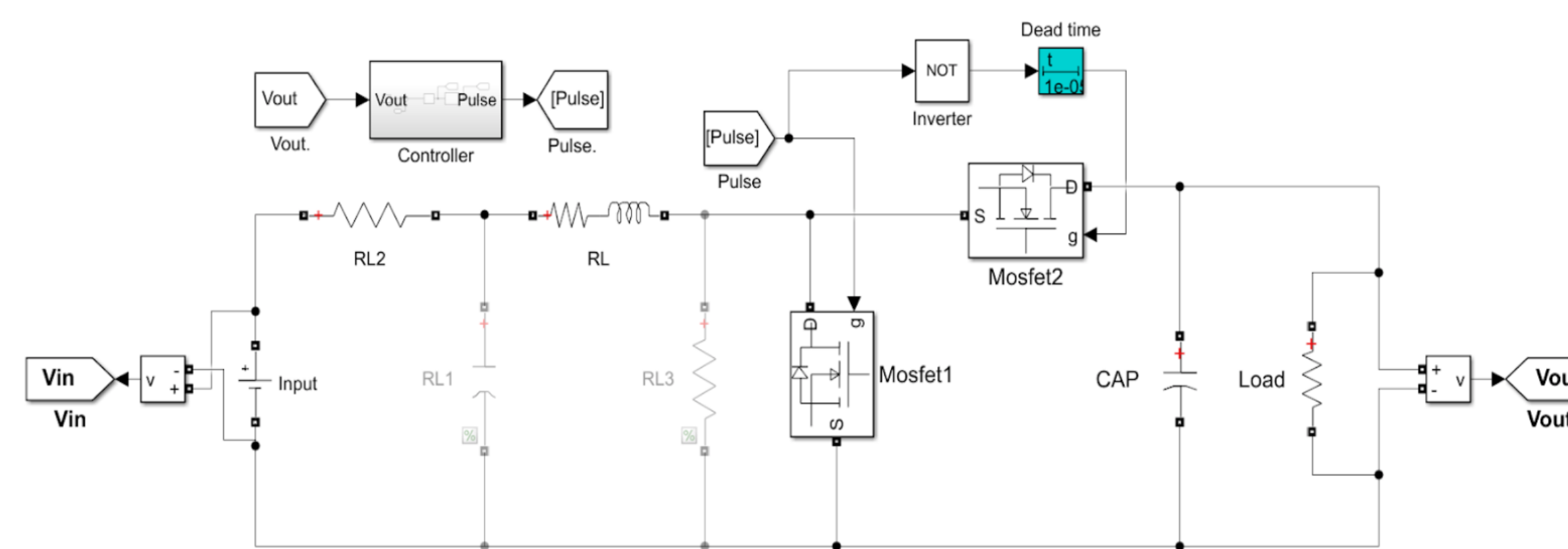

Fig. 3: Synchronous Boost Converter with PI Control

The Auxiliary team prioritized the selection of primary and peripheral components that complimented the DC-DC team's topology. Furthermore, the Auxiliary team helped design breaking control theory for three key events; a disconnect from the point of common coupling, an emergency shut off switch, and a power dump in the case of the turbine reaching "runaway speed" ( $> 20,000rpm$ ).

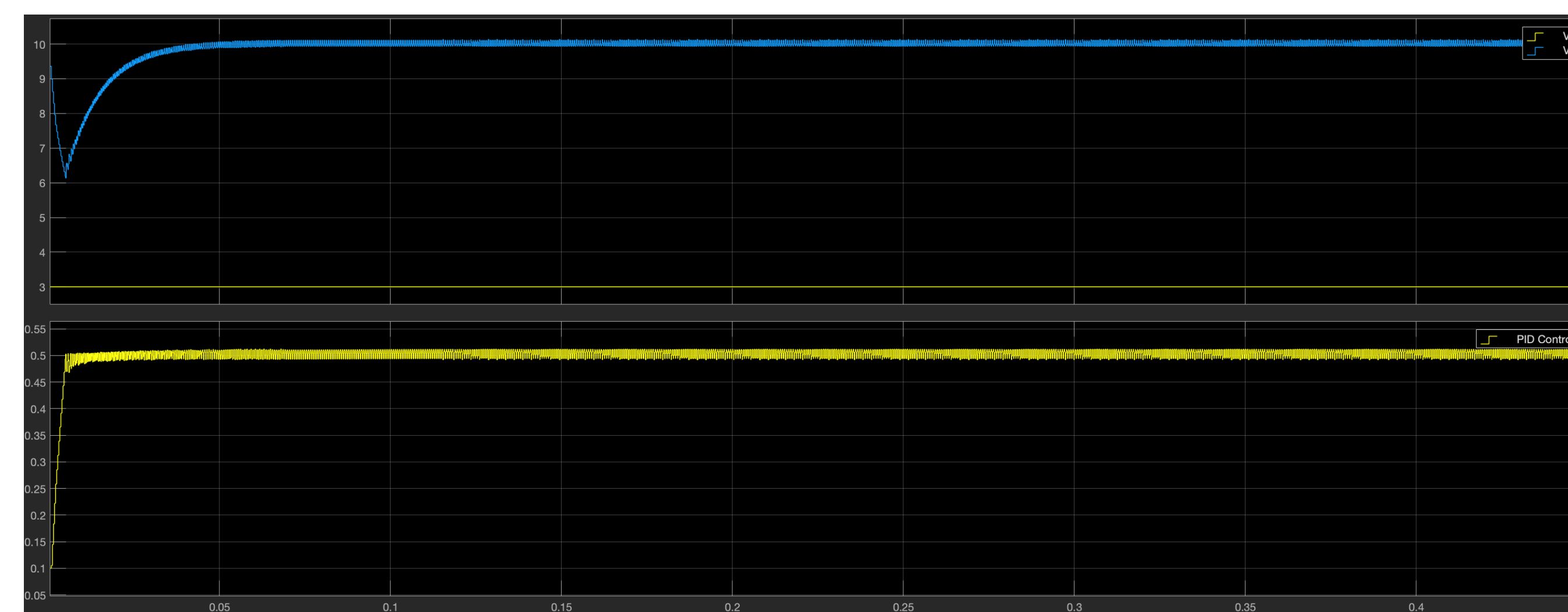

Fig. 4: Synchronous Boost Converter with PI Control: Simulation

The schematic (Fig. 2.) integrates all design work from each team, from the AC-DC rectifier, through all DC-DC conversion stages, to the point of common coupling (PCC). Peripheral circuitry, such as LED indicators, current and voltage measurements, dump-load circuit, and Arduino connections were also included to simplify testing and minimize external wiring. This schematic was transformed into the printed circuit board (PCB) (Fig. 5.) in a collaborative effort by both teams.

## Conclusion

The in-person CWC has been moved to a virtual stage. Likewise, our team interaction is now remote, making the physical completion of our project impossible in its original form. Soldering, turbine integration, and testing will not be realized due to these restrictions. However, our digital modeling and circuit analysis data verifies the design objective: a low cut-in speed for power production, steady output voltage, and minimal power loss while providing optimal visual feedback for the team.

Due to the Corona virus, the teams have shifted focus to document all technical aspects of the project for future review. This technical documentation will be the basis of grading for the virtual CWC in June, and a resource for future NAU teams.

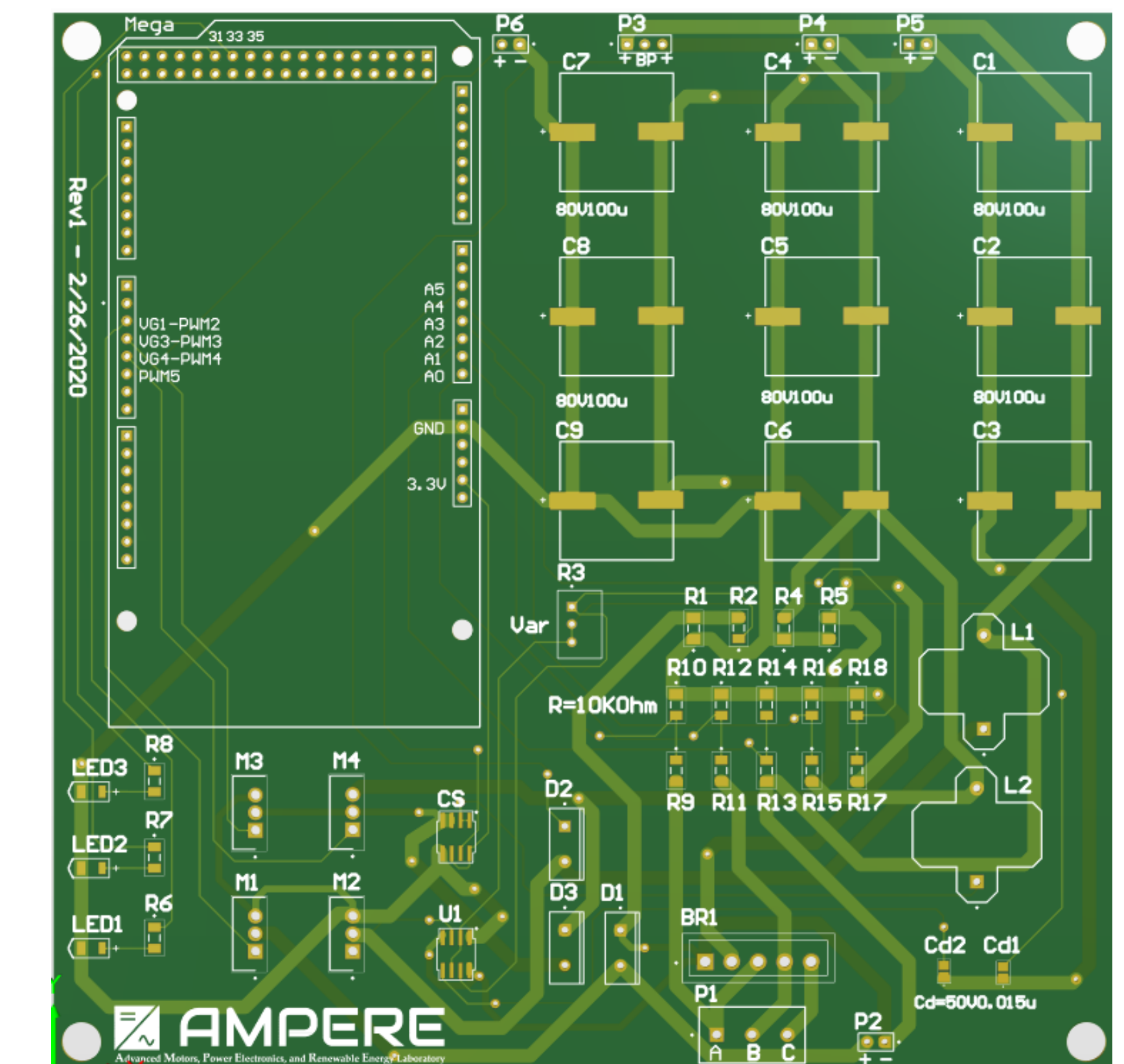

Fig. 5: Printed Circuit Board

## References

- [1] V. Yaramasu, B. Wu, P. C. Sen, S. Kouro, and M. Narimani, "High-power wind energy conversion systems: State-of-the-art and emerging technologies," *Proceedings of the IEEE*, vol. 103, no. 5, pp. 740–788, May 2015, ISSN: 1558-2256. DOI: 10.1109/jproc.2014.2378692. [Online]. Available: <http://dx.doi.org/10.1109/JPROC.2014.2378692>.
- [2] U. D. of Energy, *Collegiate wind competition 2020*. [Online; accessed April 10, 2020], 2020. [Online]. Available: <https://www.energy.gov/sites/prod/files/2020/04/f73/cwc-2020-rules-requirements-1.pdf>.

## Acknowledgements

Our teams would like to thank our clients, instructor, and mentor, who supported and challenged us over the past year: Dr. Venkata Yaramasu, [venkata.yaramasu@nau.edu](mailto:venkata.yaramasu@nau.edu), Mr. David Willy, [david.willy@nau.edu](mailto:david.willy@nau.edu), Dr. Kyle Winfree, [kyle.winfree@nau.edu](mailto:kyle.winfree@nau.edu), and Jason Foster, [jf727@nau.edu](mailto:jf727@nau.edu).