

Design Review III



SciKids

Gwen Morris, Claudia Coronel, Samantha Earl

Sponsor: Elizabeth Glass

Mentor: Austin Sanders

Scikids Client/Mentor

- Elizabeth Glass
 - Director of Career Development
- Austin Sanders
 - Graduate student

NORTHERN
ARIZONA
UNIVERSITY



*College of
Engineering, Forestry
& Natural Sciences*

**School of
Forestry**



Figure 1 - Elizabeth Glass

Problem Statement and Solution

General Problem

- Market for STEM
 - Rapid job growth in comparison to workforce
- Lack of resources and interest
- Sponsor interest
- Increase sponsor reach

Solution

- Gesture-based learning system
 - Recognizes and detects gestures
- Extensible modules
 - Easy for new developers to update
- Garner interest in specific areas
 - Engaging and informative way using gamification elements

Requirements

1. Users will be able to use gestures as a means of navigation through the system.
2. Users will be able to create a profile and see personalized available modules.
3. Users will be able to save personal progression and store high scores.
4. System must be intuitive and easily extensible for future developers.

Architectural and Implementation Overview

High Level Overview

- Navigational system (GUI)
- Local SQLite Database
- Gesture Mapping
 - Intel D435
 - Nuitrack SDK
- Scene Backend

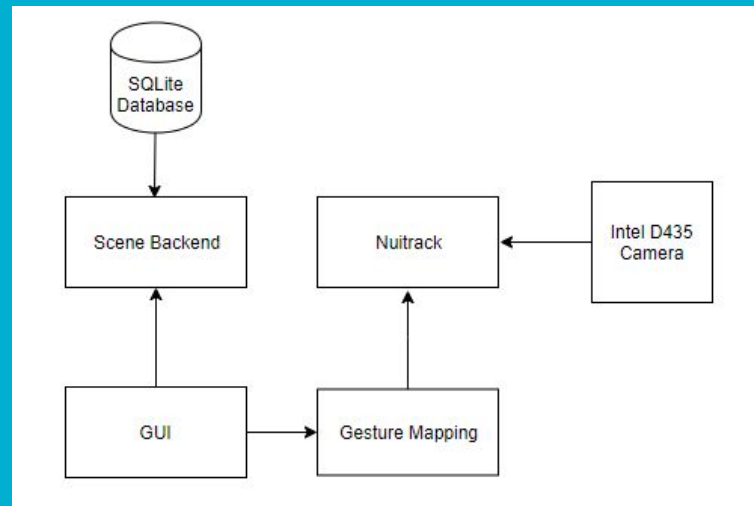

Figure 2 - Architecture Diagram

Implementation Overview

- Intel RealSense D435 Camera
 - Has built-in depth sensors, RGB sensor, and infrared projector.
- Nitrack
 - Middleware that can track a 3D skeletal body and has gesture recognition.
- Unity
 - A game development platform that is compatible with a wide range of technologies.

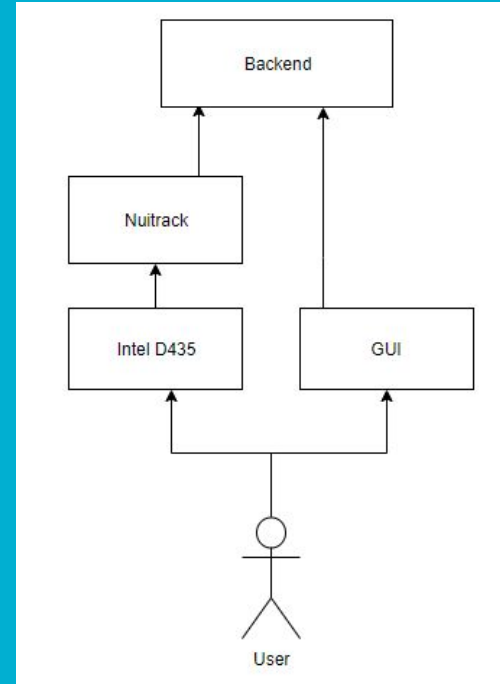

Figure 3 - System Diagram

GUI/Database

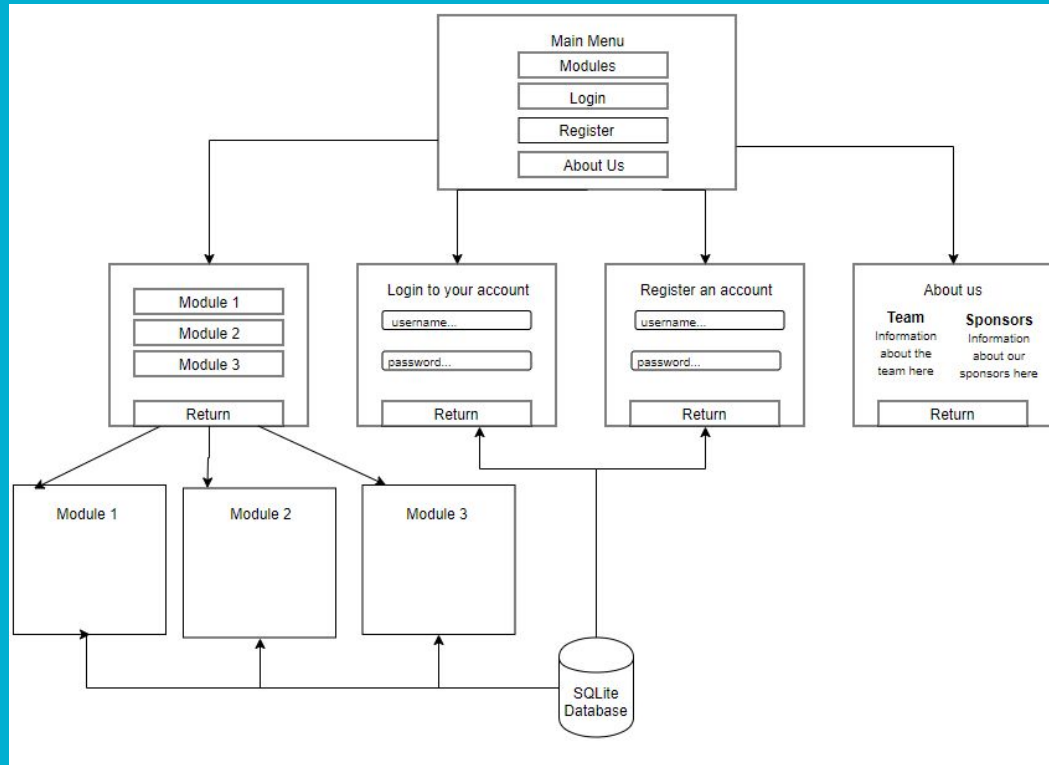
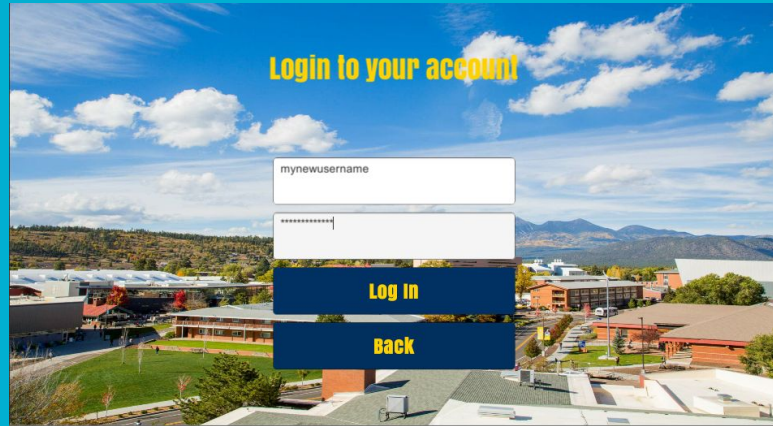

Figure 4 - Menu Layout

Scene Backend

- Scenes contain the environments and menus of the project
- C# scripts, sprites, prefabs, animations, etc.
- Scenes in our system
 - Login
 - Registration
 - Each module
- Extensible



Login	
+	nameField: InputField
+	passwordField: InputField
+	errorDisplay: Text
+	submitButton: Button
-	id: int
-	Start()
-	TaskOnClick()
-	accountExists()
-	getID()
-	loadConnectionString()

Figure 5 - Login scene and backend

Gesture Mapping

- NuiTrack - full body skeletal tracking software with gesture recognition
- Hand Tracker module
- C# scripts

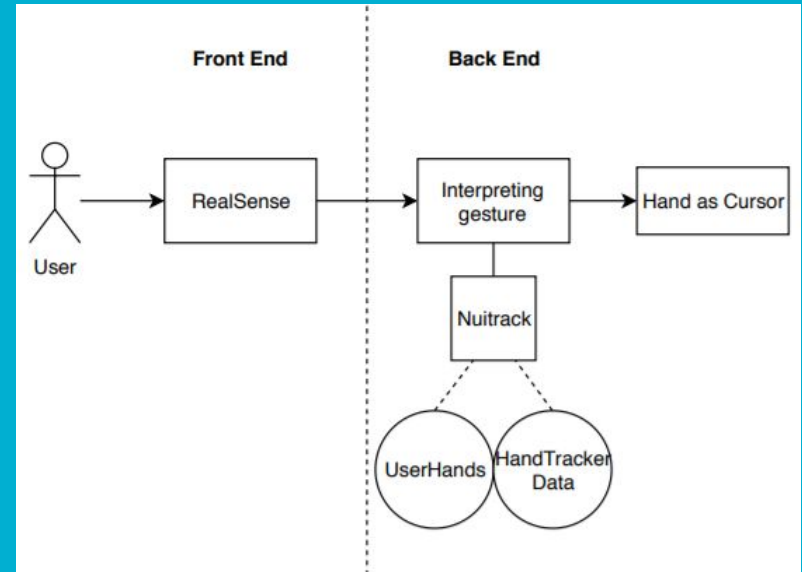

Figure 6 - Gesture Diagram

Prototype Review

Login System

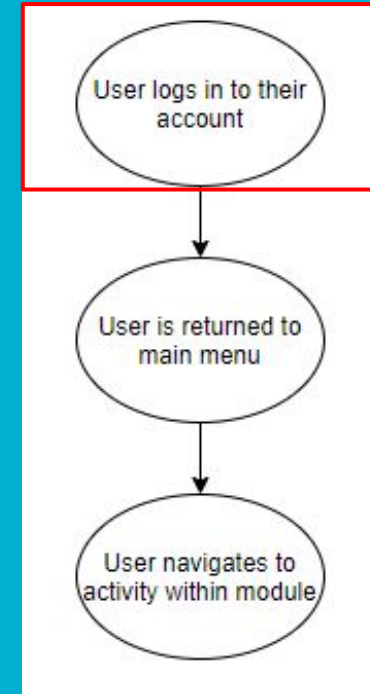
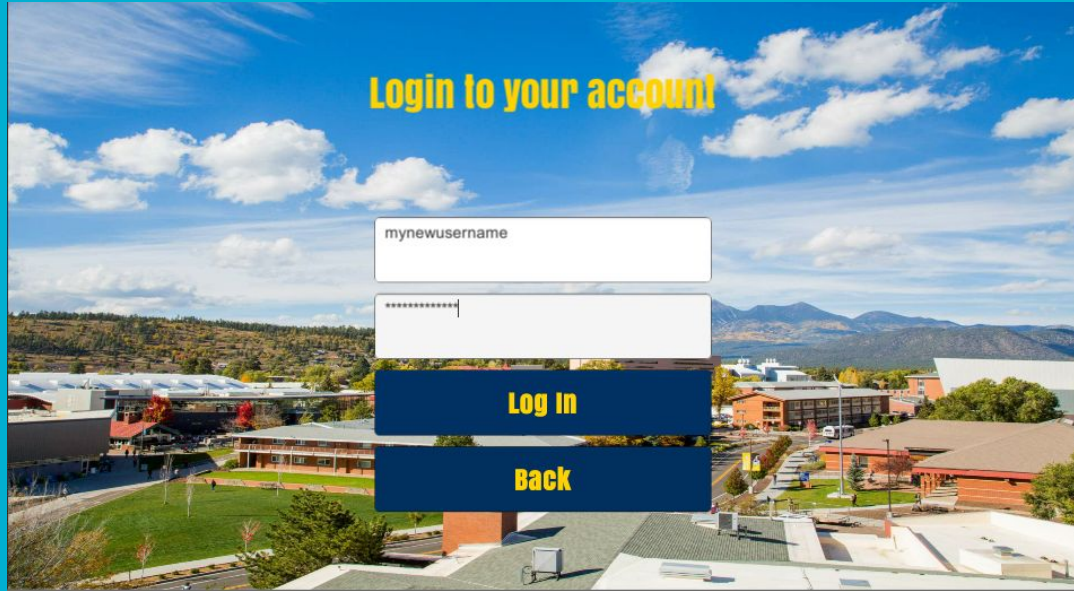

Figure 7 - Flow diagram

Login System continued...

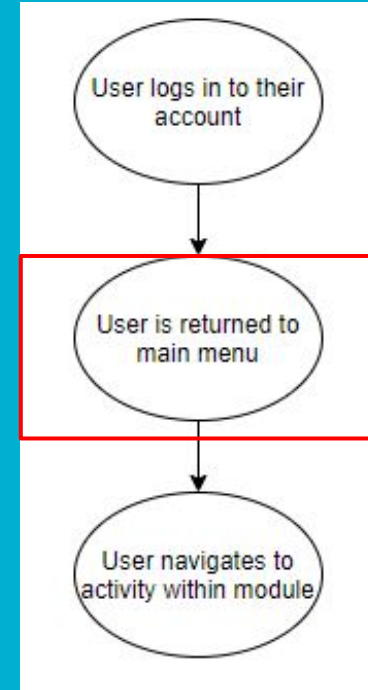

Figure 7 - Flow diagram

K-5 Module

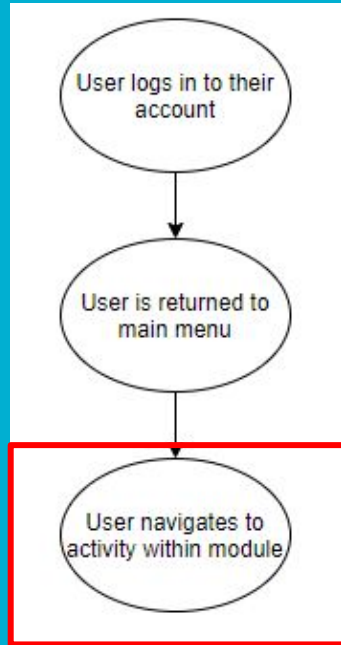

Figure 7 - Flow diagram



Community College Module

Quit Game

Job Details

Greg

Phil

Tyrone



PHIL: I have experience in Java and C++. I have 2 years of SQL experience. I am also available to move if needed.

Continue

Entry Level Software Engineer

What We Are Looking For

- MUST have a Bachelor's Degree
- 0-3 years experience
- Excellent problem solver
- Solid understanding of Object Oriented Programming
- Outstanding verbal and written communication skills
- Exposure to one of the following: Java, Javascript, C++, CSS
- Solid foundational knowledge of SQL
- Willing to relocate anywhere in the US
- Must be authorized to work in the US on a permanent basis - ability to secure

Back

Figure 8 - Community College Module

Implementation challenges, Schedule

Challenges and Resolutions

Technology Risks

- Technology being used is very new.
 - Not much community support with NuiTrack.
 - Resolution: Actively checking NuiTrack forums
- Accuracy issues
 - Tracking hand movement and an open and closed fist
 - Resolution: Recalibrating the config files and adding a hover-to-click option

Business Risks

- Learning curve for users is steep
 - Users must memorize gestures rather than symbols.
 - Resolution: A short tutorial
- User Fatigue
 - Long exposure may lead to muscle fatigue
 - Resolution: Have a time limit for each game.

Schedule

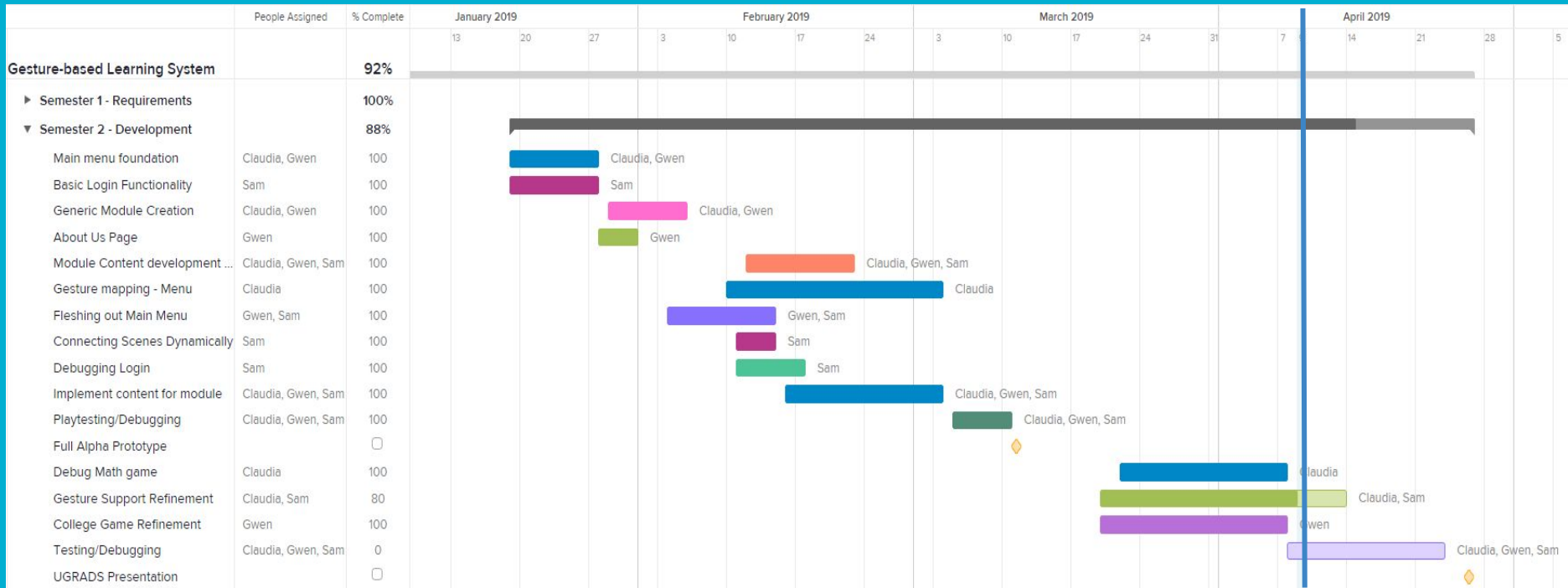

Figure 9 - Gantt Chart

Testing Plan

Unit Testing

- Using Unity TestRunner
- 5 test classes

Test	Equivalence Partitions	Boundary Values	Sample Input/Action	Expected Outputs
UserFound()	N/A	N/A	User stands in front of depth sensing camera	User's body is interpreted with NuiTrack's SDK. A text will appear on the screen saying "User found"
HandTracking()	N/A	N/A	User stands in front of the depth sensing camera and waves their right hand around the screen	User's hands are interpreted with NuiTrack's SDK. A text will appear on the screen showing coordinates of hands at a specific moment in time
ItemDestroyed()	N/A	N/A	User stands in front of the camera and touches objects on the screen.	User's contact with the objects will cause them to disappear, triggering a text on the screen displaying "Destroyed"

Integration

Integration Test	Sample Input	Expected Output
Math activity can edit database through DBManager.	A user who is logged in sets a new high score in activity.	The value for userScore in the "score" table is updated.

Usability

Purpose:	The user will find the system engaging and enjoyable
Task:	Run through the respective module in your age group, try at least one of the activities
Plan:	Taking at least two individuals for each of the modules we have developed and asking them their opinions on the content. Posing the right questions based on graphics and gestures.
Survey	<ul style="list-style-type: none">• Did you find the material engaging and informative?• On a scale of 1-10 how enthusiastic were you to continue?• Would you use this system again?

Summary

Conclusion

- Team SciKids, working with Elizabeth Glass
- There is a growing need for workers with an STEM-based education.
- We are creating a gesture based learning system to encourage users to pursue STEM careers.
- Prototype:
 - Login system, personal progression, gestures, gamification
- Testing plan:
 - Unit, integration, usability
- Future:
 - Finalize tests
 - Write out user documentation