



# Design Review 2



## Team FitByte

Jake Farrar, Jacob Lemon, Austin Pederson

Sponsors: Dr. Kyle Winfree, Dr. Gregory Dominick  
Mentors: Ana Paula Chaves Steinmacher, Dr. Eck Doerry

# Bio-Behavioral System to Motivate and Reinforce Heart Health

- Heart Health
- Project Goals

Top 10 global causes of deaths, 2016

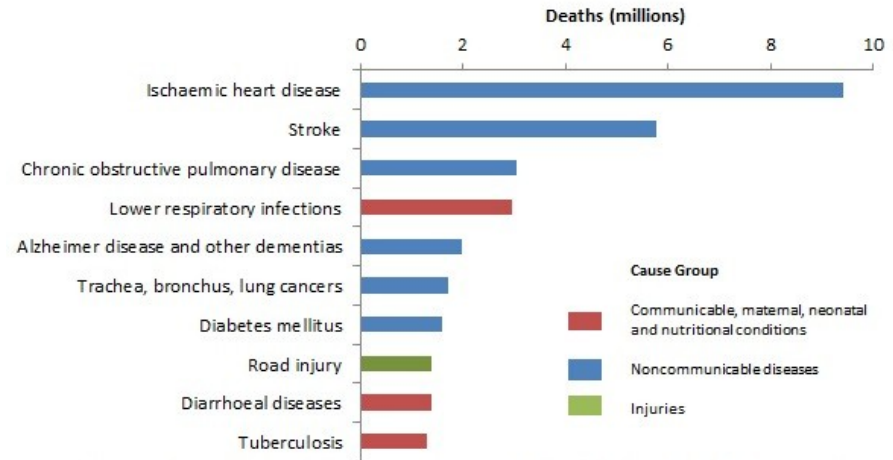

Source: Global Health Estimates 2016: Deaths by Cause, Age, Sex, by Country and by Region, 2000-2016. Geneva, World Health Organization; 2018.



## Sponsors



Dr. Kyle Winfree, NAU



Dr. Gregory Dominick, UDel

# Currently Working Solution

- Developed by NAU employee, Mike Fell
- Problems with solution
  - Localized
  - Limited Analysis

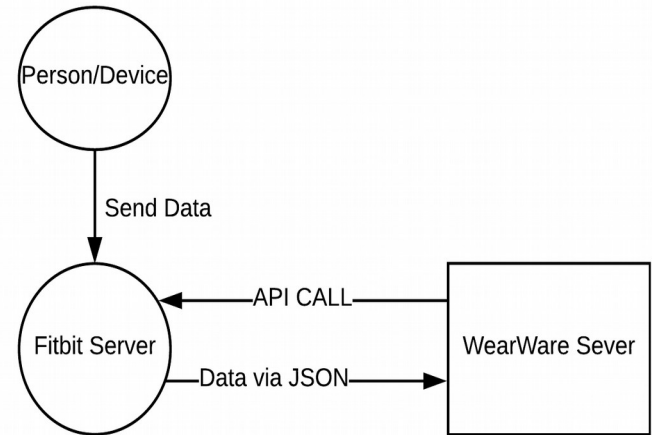



# Solution

- Updated WebApp
  - MVP
- Analysis software used
- SMS messages
- API access



Dashboard  
Studies  
Participants  
Scripts

## Administrator Dashboard

Welcome, Dr. Kyle Winfree!  
[Edit Account](#)

Hello World!!!

Today is Feb. 27, 2019

Message of the day:  
This is the message of the day!

### Admin Functions

[Update Octave](#) [Update SVN](#)

Study	Date Created	Number of Participants	...
1	...	...	...
2	...	...	...
3	...	...	...



# Implementation Overview

- Amazon Web Services
- Django Web Framework
- PostgreSQL
- Octave
- Twilio

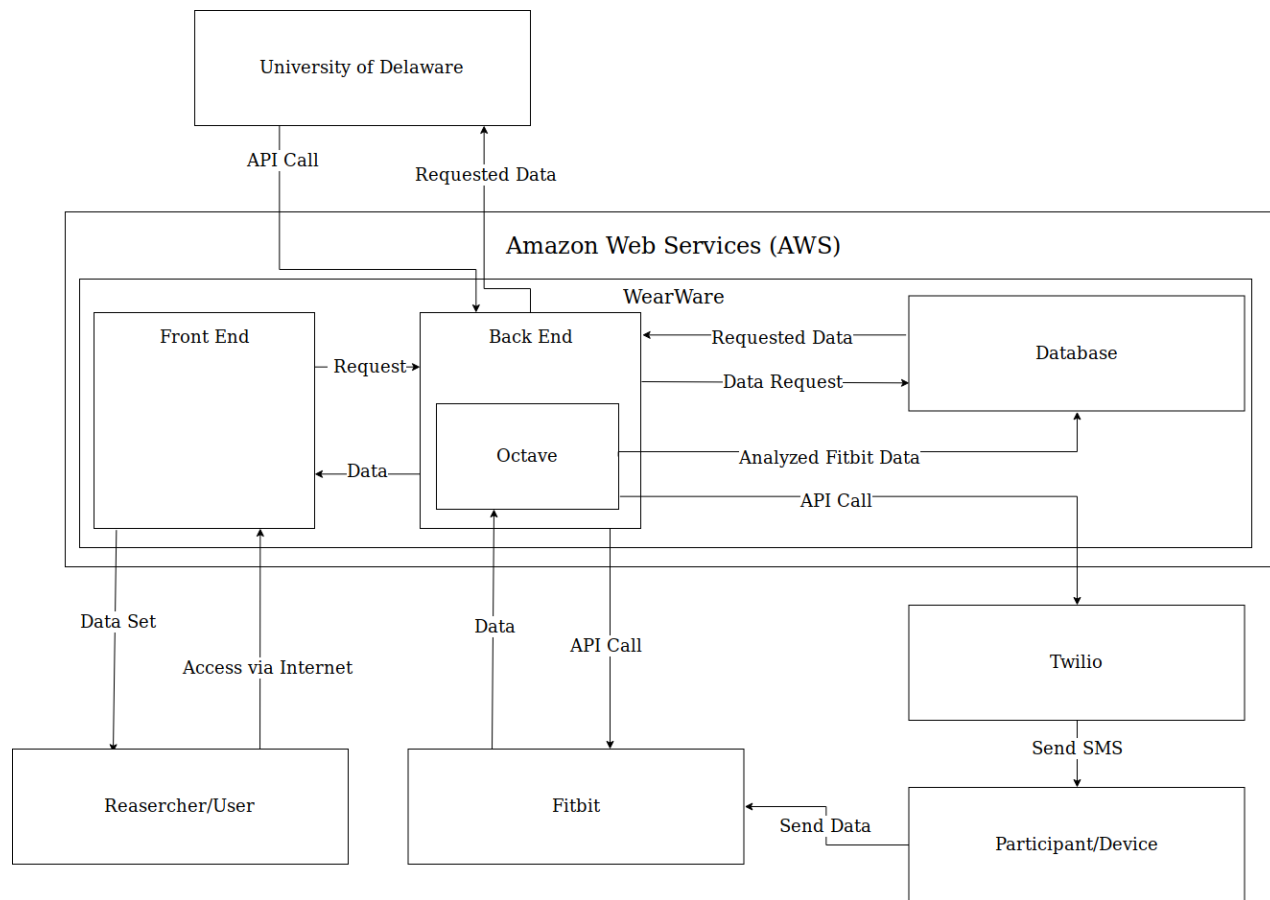



# Architecture Overview

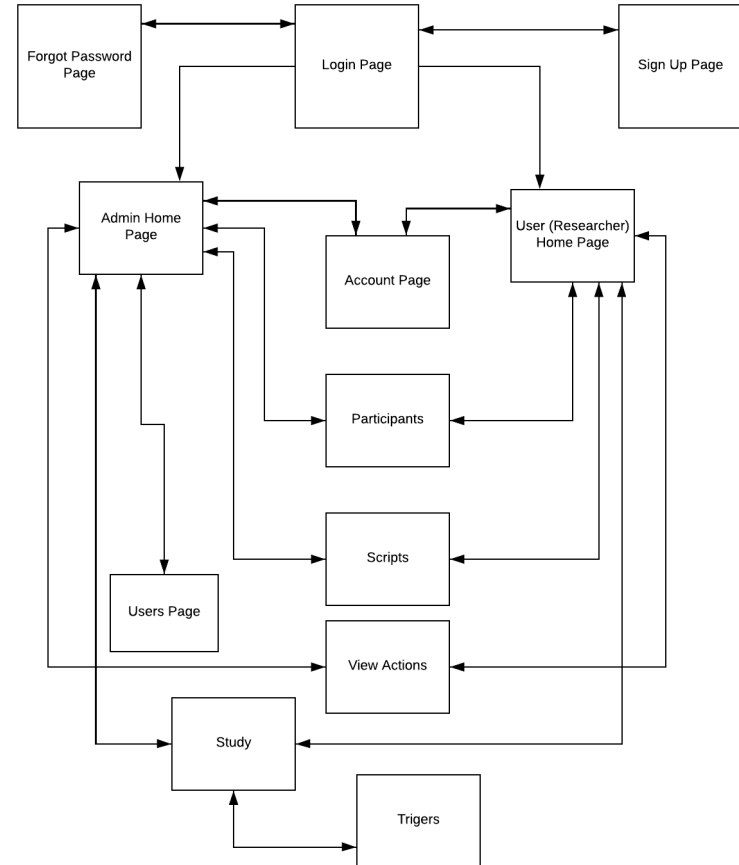



# Flow of Homepage

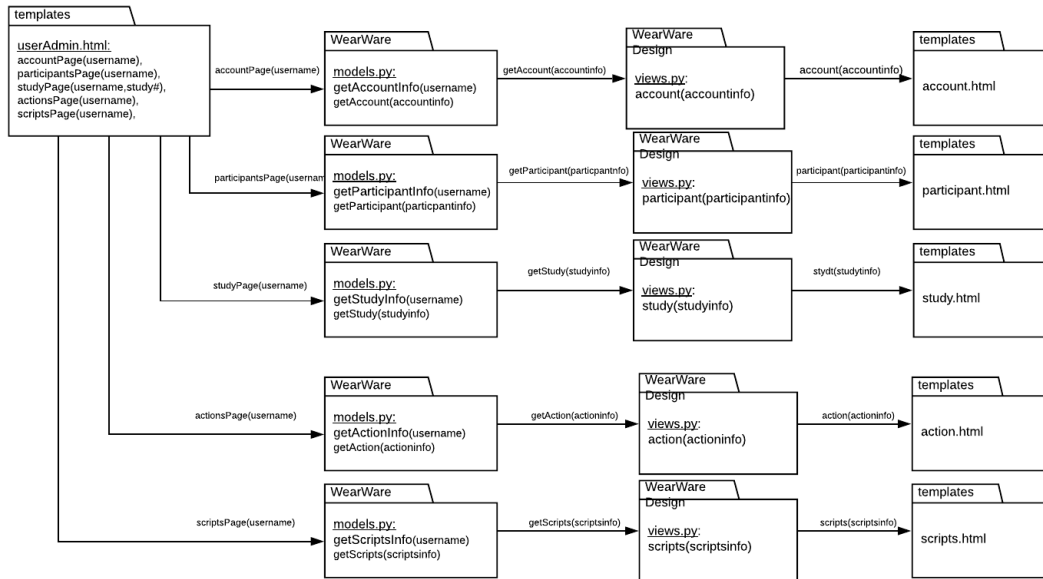

Dashboard

Studies

Participants

Scripts

Welcome, Dr. Kyle Winfree!

[Edit Account](#)

## Administrator Dashboard

Hello World!!!

Today is Feb. 27, 2019

Message of the day:  
This is the message of the day!

**Admin Functions**

[Update Octave](#) | [Update RIN](#)

Study	Date Created	Number of Participants	...
1	--	--	--
2	--	--	--
3	--	--	--



# Challenges

1. Large number of users in the database
2. Potential Security Flaws



# Schedule

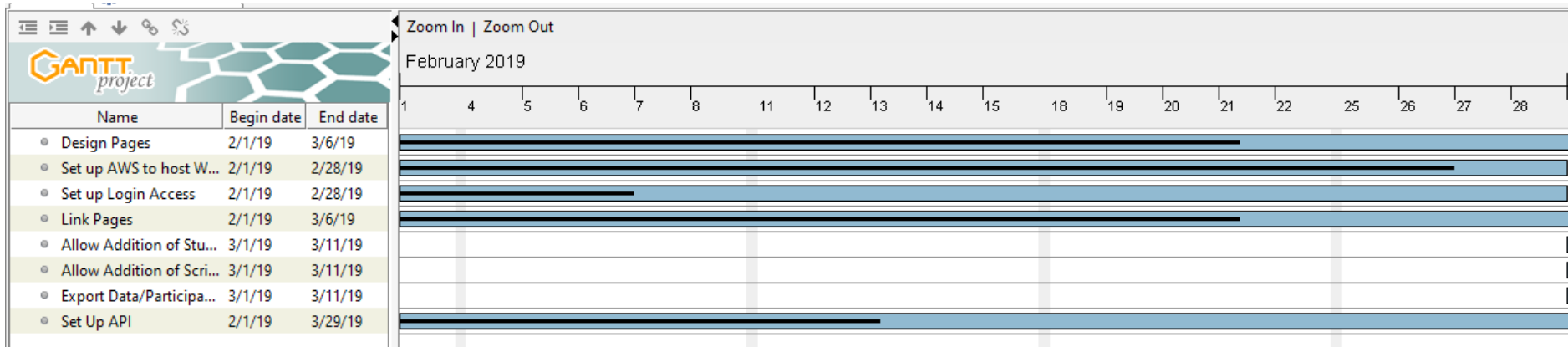



# Conclusion

- Working with Dr. Kyle Winfree and Dr. Greg Dominick
- Improve their web application, WearWare
- Plan to improve the UI
- Implement an API
- Implement notifications