



ALTERNATIVE SEPTIC SYSTEM & IRRIGATION SYSTEM FOR A VINEYARD ON OAK CREEK

Alternative Septic Team

ABSTRACT

A proposal for an alternative septic system, irrigation system design, and water quality analysis at the request of Adam Bringhurst.

Carly Akine, Abdullah Alkandari, Dylan Norfleet, Will Richardson

CENE-486

Table of Contents

Acknowledgements	1
Project Introduction	1
Technical Background	2
Field Work	2
Testing	2
Alternatives Pursued	3
Alternative Septic Systems	3
Vineyard Irrigation	6
Alternative Septic System Design	7
Alternative Septic System	7
Disposal Works Design	8
Vineyard Irrigation System Design	9
Vineyard Water Demand	9
Methods	10
Estimation of Water Demand	10
Drip Irrigation System	11
Dripline System	11
Mainline Irrigation System	13
Storage Tank	14
Irrigation Supply Pump	14
Pressure Tank	15
Submersible Pump	15
Water Quality Analysis For Drinking Water Well	16

Cost of Implementation	17
Summary of Engineering Work	17
Summary of Engineering Costs	17
Conclusion	19
Appendices	22

Table of Figures

Tables

Table 1: Alternative Septic System Requirements	7
Table 2: Leach Field Sizing Design	8
Table 3: Pressure-loss in Dripline	12
Table 4: Dripline Design	13
Table 5: Pressure-loss in Mainline	14
Table 6: Water Quality Results	17
Table 7: Cost of Engineering Work [21]	19
Table 8: Overall Project Proposed Costs	19
Table 9: On-site Percolation Test Times	24
Table 10: Tap Water and Creek Hanna Meter Readings	24
Table 11: Total Nitrogen Sample Testing Data	24
Table 12: Nitrate Sample Testing Data	25
Table 13: Fecal Coliform Testing Data	25
Table 14: Decision Matrix for Irrigation Design Selection	26
Table 15: Flow in Irrigation System per No. of Emitters	26
Table 16: Description of Numbered Locations on MicroFAST System Figure	28

Figures

Figure 1: Aerial view of property [1]	1
Figure 2: Aerobic Septic System Components [3]	4
Figure 3: Schematic View of Wisconsin Mound Septic System [4]	4
Figure 4: Sequencing Batch Reactor (SBR) [5]	5
Figure 5: 5000-gal Storage Tank [16]	15
Figure 6: Irrigation Supply Pump [17]	15
Figure 7: Pressure Tank [18]	16
Figure 8: Submersible Pump [19]	17
Figure 9: MicroFAST Aerobic Treatment Unit [24]	27

Acknowledgements

The Alt. Septic Team would like to thank Adam Bringhurst, our client and the supporter for the project. Adam provided feedback when we had any concerns and made himself available for all site visits. We would like to acknowledge Dr. Paul Gremillion for providing us with feedback and experience regarding our project. Also, special thanks to Dr. Terry Baxter for preparing for us with lab equipment. Finally, thanks to our grader and technical advisor, Alarick Reiboldt, for guiding us as we navigated complications in the project. We appreciate all the professionals who were grateful for our concerns and contributions.

Project Introduction

The property location address is 2955 N. Echo Canyon Road, Cornville, AZ. It is a 4.5-acre size, mostly flat land with a hill on the West side of the mobile house and the river on the East side. Our client is Adam Bringhurst, his father-in-law owns the property. The client requested several objectives to be completed. The objectives are as follows: design an alternative septic tank system that is in compliance with Yavapai County, design an irrigation system for a future vineyard to be installed, conduct a water quality analysis of the drinking water well, and create a 1-ft topographic map to measure the contour elevations. Figure 1 displays the location and aerial view of the property and a topographic map of the property can be found in the attachments.

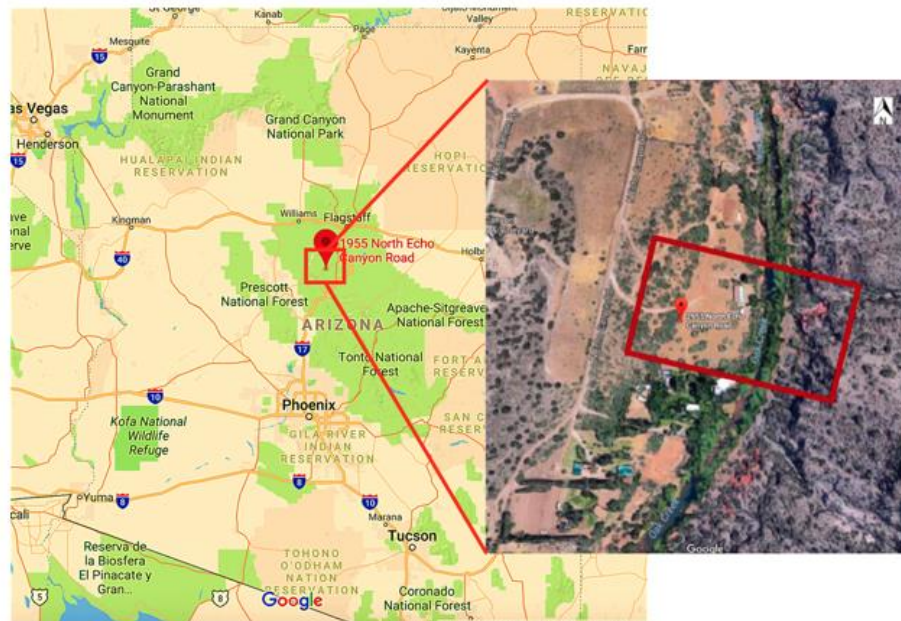

Figure 1: Aerial view of property [1]

Technical Background

Field Work

The field work consisted of the team completing an on-site survey, water analysis, and soil analysis. The survey was done in order to gather point to later generate a 1-ft topographic map of the site, where changes in elevation will be considered during the irrigation system design. The water quality analysis included pH, temperature, and conductivity testing using a Hanna Meter. This testing was done for the water out of the tap, directly from the well, and also the adjacent creek. This information gathered through the Hanna Meter will be used to ensure the current pH and conductivity values in the well water system are normal. Values from creek will be used as a reference to the drinking water data and to see if there is a direct influence from the creek water to the aquifer that the well is drawing from. Water samples from the well, tap, and creek were also taken to be tested in the lab. Also, completed on-site were three percolation tests to determine the soil absorption rate at each location. This data will be analyzed and used for determination of the possibility and location of a leach field for an alternative septic system.

Testing

Water quality testing was conducted by the team on the collected samples. Water collected from the tap, well, and creek were tested for total nitrogen, nitrates, and fecal coliform. On site, a percolation test was conducted in order to determine the hydraulic conductivity of the soil.

HACH Method 10071 was used to determine the total nitrogen levels in the water. Seven tests were conducted; there were two samples tested from both the well and tap, two samples were blanks, and one sample was tested from the creek. The results may be viewed in the Appendix. The results of the original total nitrogen testing were inaccurate, as the test yielded negative values. Ergo, new samples were collected from the well and tap and total nitrogen testing was performed again and yielded accurate values. As the total nitrogen components represent the sum of all species that may be converted to nitrates, the total nitrogen levels should be low to ensure safe consumption.

HACH Method 8192 was used to test for nitrates in the water. One sample was taken from the well and tap, one sample was blank. The results from this test may be viewed in the Appendix. These results are accurate, as the values are relatively low.

HACH Method 8074 was used to test for fecal coliform in the water samples. Two samples from the well were tested; one undiluted and one diluted 1:5. Three samples were tested from the creek; one undiluted, one diluted 1:10, and one diluted 1:100. One sample from the tap was tested and was undiluted. The results from this testing may be viewed in the Appendix. These results are believed to be accurate, as there were no fecal colonies found in the water sources. The creek would be the most likely to have fecal colonies, but as the water was sampled during a cold time of year, and the water was undisturbed due to the lack of rainfall, it is possible the sample taken contained zero fecal

colonies. We would suggest retesting the well and creek for fecal coliform during summer months, but given the timeline of the project, we were unable to perform this analysis.

An EPA method was used to conduct the percolation testing. As recommended by the procedure, three holes were dug, 6-in in diameter and 12-in deep. The holes were filled with water twice before being timed during the third filling. One test was conducted directly in front of the house, on the side of the hill on the west side of the property, and one on the south side of the road that runs through the property. The location of these tests can be seen on a topographic map of the property in the attachments. The results from the percolation testing may be viewed in the appendix.

Alternatives Pursued

Alternative Septic Systems

The primary consideration when designing an alternative septic system is the regulatory requirements, design requirements, and the maintenance required for each system. Such regulatory requirements can be found in 18 A.A.C. 9, Article 3, which describe requirements for design and site investigations for all septic system designs permitted in Arizona. When considering the possible septic systems, the possible alternative septic system designs are listed in 18 A.A.C. 9, as R-18-9-E303 to R-18-9-E322 [2]. Although not all of these systems will be feasible for the site conditions, this is the list of systems that may be approved by the county.

The team researched three alternative septic systems that met the requirements provided by the A.A.C. An aerobic septic system, wisconsin mound septic system, and a sequencing batch reactor septic system were pursued.

Aerobic Septic System

Aerobic septic systems allow for treatment of wastewater in many areas where conventional septic tanks are not allowed. These systems work similarly to a wastewater treatment plant where influent water is run through a series of tanks that each have a different purpose for treatment. The first is a primary treatment tank, where larger solids are removed to prevent clogging for the later portions of the system. The second stage consists of aeration and agitation of the wastewater. This addition of air is to promote the growth of aerobic bacteria which help to breakdown much of the solids and waste within the water. The water is then sent to the clarification tank where any remaining solids that were not consumed by the bacteria can settle out. Finally, the water goes to the last tank where chlorination of the water is applied to kill any pathogens, microorganisms, or bacteria that are still present. When this tank fills to a certain point, the water is pumped out to a drain or leach field. These systems differ from traditional septic systems because traditional systems utilize anaerobic bacteria for treatment, which do not treat the effluent water to as high of a standard as aerobic bacteria can. This makes aerobic septic systems more viable in areas where high water tables, sensitive soil or ecosystems, and flooding is present or common.

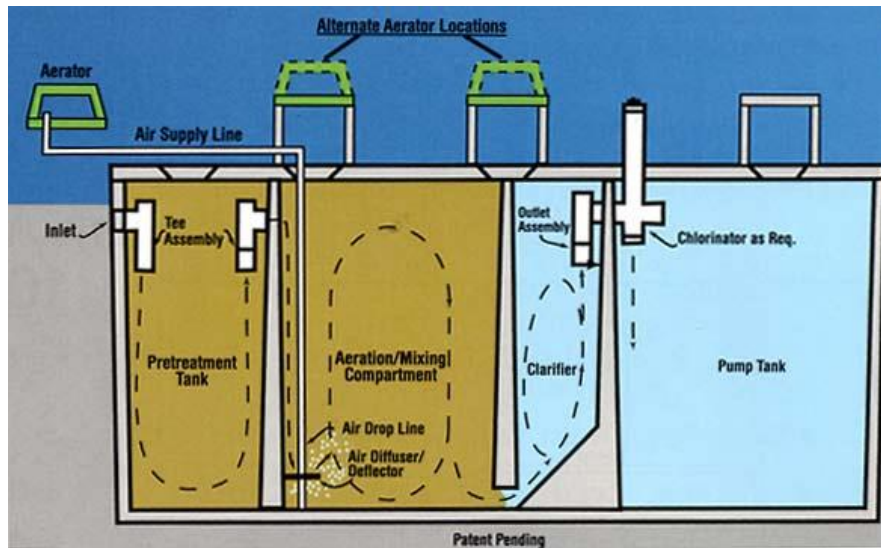

Figure 2: Aerobic Septic System Components [3]

Wisconsin Mound Septic System

The Wisconsin Mound system can work in rain and protects the water table. However, it requires outside materials to be brought for construction of the mound, and it cannot be within the 100-year flood plain. Also, it requires a lot of pipelines, design, testing, inspections, and space to obtain [4]. Figure 3 illustrates a schematic view of a Wisconsin Mound System. It consists of a septic tank, dosing chamber, and the mound [4]. The septic tank allows heavier solids to settle to the bottom while oils, grease, and smaller solids float to the surface. The clarified water from the middle will then go through the dosing chamber which contains a siphon and a pump. The effluent will be pumped to a higher elevation in order to percolate through the mound, which will remove the accumulated pathogens and organic matter.

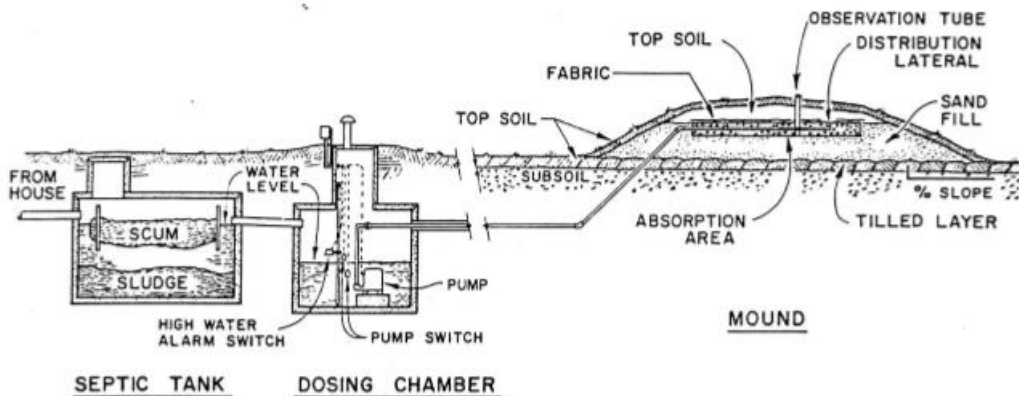

Figure 3: Schematic View of Wisconsin Mound Septic System [4]

Sequencing Batch Reactor Septic System

The Sequencing Batch Reactor (SBR) Septic System shown in Figure 4 depicts the steps that are generally followed for these systems. These steps all occur in one tank.

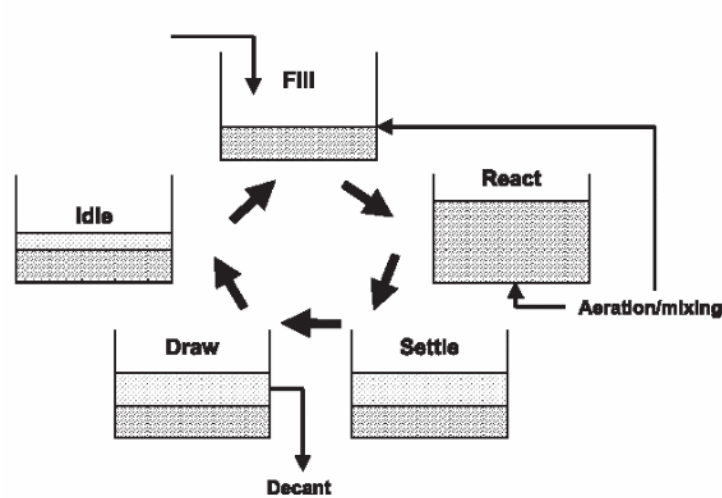

Figure 4: Sequencing Batch Reactor (SBR) [5]

SBRs treat the wastewater with a process similar to the aerobic septic systems but are confined to one single tank. SBRs use activated sludge to remove nitrogen, phosphorus, ammonia, TSS, and BOD from wastewater. SBRs are designed to treat intermittent flow conditions and treat wastewater to a higher degree than a conventional septic system due to the use of aeration.

Once the tank is filled with wastewater, the aeration and mixing processes occur. The addition of oxygen to the wastewater promotes the growth of aerobic bacteria that consume the nutrients. Once finished, the aeration ceases and the heavy solids settle to the bottom of the tank. The treated water is pumped to a drain field and the excess sludge is removed from the tank.

Vineyard Irrigation

The main considerations with designing the irrigation systems is determining the type of irrigation system and calculating the required dynamic head to pump water through the system. The various irrigation systems that have been deemed feasible for this project include drip irrigation, subsurface drip irrigation, and spray irrigation.

Drip Irrigation

In drip irrigation, water flows through pipes slightly above the ground and drips almost directly on the crops. This method reduces evaporation and transpiration that would occur with other irrigation methods. This method reduces the wetted area and requires less pressure within the system. This can increase the yield of crops and the efficiency of the system. As well, this system is not labor

intensive and can irrigate on a slope or irregularly-shaped land [6]. Alternative to having the pipes above the ground, a study was conducted on the efficiency of placing the drip irrigation system underground and found it to be just as efficient as the traditional above-ground system. As well, the study found that the lifetime of a subsurface drip irrigation is long, assuming the system is designed correctly and maintained [7].

Subsurface Drip Irrigation

Subsurface drip irrigation precisely delivers water to the roots of the crops through buried tubes. As the pipes are placed under the soil's surface, the water lost to evaporation, evapotranspiration, and runoff are minimized. Like drip irrigation systems, this precise application of water can increase crop yields and decrease the growth of weeds. These systems are ideal in arid, semi-arid, hot, and windy areas with limited water supplies [8]. However, unlike traditional drip irrigation, maintenance is more difficult as the pipes are buried underground.

Spray Irrigation

Spray irrigation is widely used, though less efficient than drip irrigation. The most common use of spray irrigation is the "center-pivot" system that utilizes electric motors to pivot a large frame to spray water over crops. Spray irrigation requires a high-pressure system and loses roughly 35% of water to evaporation [9]. Low energy precision application (LEPA) spray irrigation does not shoot water through the air, but the pipes hang low to the ground and spray water directly onto the crops. This type of application allows for only a 10% loss of water as it closer resembles the efficiency of drip irrigation than traditional spray irrigation [10].

Alternative Septic System Design

The final design for the alternative septic system involves two main components, the actual septic system which treats the influent, and the disposal works which treats the effluent from the septic system. This section addresses the final proposed design for both components.

Alternative Septic System

Based off of the alternative septic systems evaluated, the initial system chosen was a sequencing batch reactor (SBR). The SBR was selected due to it being the most applicable in situations with intermittent flows. Since the client stated that people would reside on the property inconsistently throughout the year, this was determined to be the best alternative system. Through research of manufactures and systems, an SBR unit of the sizing needed for the site location was difficult to come by and on average transportation costs would have resulted in high overall expenditure. Since all septic systems had to meet A.A.C. code for approval, aerobic septic systems availability and sizing were then considered. Both the aerobic system and an SBR would have to meet the same total sizing, flow rates, and effluent standards. Therefore, the main comparison between the two applicable

systems became availability and cost. The following table organizes requirements set out by Arizona Administrative Code for alternative septic systems as per A.A.C. R18-9-A314.

Table 1: Alternative Septic System Requirements

Component	Requirements
Total Sizing of Tank	1000-gal
Hydraulic Loading	300-gpd
Effluent TSS	30-mg/L
Effluent BOD	30-mg/L
Effluent Total Nitrogen	53-mg/L
Effluent Total Coliform	300,000 colonies/100 mL

The system chosen was the MicroFAST 0.5 aerobic treatment unit made by Biomicrobics. Aim Environmental Industries is a distributor of these systems located in Lake Havasu. They were able to provide a rough estimate for a quote of the MicroFAST system itself as well as the tank it resides in, a UV disinfection chamber for further effluent water treatment, and transportation to the site. This quote was for \$12,000 and is a rough estimate due to the fact that Aim Environmental Industries requires a site visit to be conducted by them before accurate costs for the system and their services are provided. The MicroFAST 0.5 system however, does meet all sizing and effluent requirements from A.A.C. and is rated to provide effluent to the standards of 30-mg/L for both TSS and BOD, 53-mg/L of TN, and 300,000 total colonies of coliform per 100-mL before the addition of the UV disinfection chamber. The UV disinfection chamber further treats wastewater by inhibiting the growth and reproduction of microorganisms, pathogens, and many bacteria thus resulting in a potentially higher rated effluent of the system. The UV chamber will specifically impact the colonies of coliform per 100-mL, which will allow the system to comply with A.A.C. for a high water table. Exact effluent numbers of the MicroFAST 0.5 system with the addition of the UV chamber cannot be provided at the current time because accurate values cannot be found without testing of effluent water once the entire system is implemented.

Disposal Works Design

Once the effluent water leaves the alternative septic system it must be distributed through a disposal works for final treatment. Location and sizing requirements are set out through Arizona Administrative code A.A.C. R18-9-E302 and A.A.C. R18-9-A312. The trench method was used for the leach field to meet A.A.C. requirements. Offsets of 100-ft from the on-site well, 10-ft from any building, and 50-ft from any property line were required. Also needed for sizing was the Soil Absorption Rate (SAR). This was found using percolation test data from location 3 since this location met all offsets and was not within the intended expansion area of the vineyard. See percolation test data in appendices for full testing time results and see topographic maps for proposed location of the leach field. The percolation rate at location 3 on the property was 1.5-min/in. Using corresponding A.A.C. tables, the SAR of that location was found to be 0.93-gpd/ft². Alternative systems require the usage of an adjusted SAR for proper sizing of a trench method leach field. This was done using the initial SAR as well as effluent levels from the aerobic system for both TSS and BOD. The following equation was taken from A.A.C R18-9-A312 for usage in calculation of the adjusted SAR.

Equation 1:

$$SAR_a = \left[\left(\frac{11.39}{\sqrt[3]{TSS + BOD_5}} - 1.87 \right) SAR^{1.13} + 1 \right] SAR$$

The Adjusted SAR was calculated to be 1.82-gpd/ft². Using this value, intended max flow rate of 300-gpd of the alternative system, and A.A.C. sizing of the leach field which uses a proposed 3 trenches was found. The following table organizes the leach field sizing design parameters.

Table 2: Leach Field Sizing Design

Adjusted SAR [A.A.C. R18-9-A312]	1.82-gpd/ft ²
Min. Surface Area of Leach Field	165-ft ²
Trench Length	19-ft
Bottom Width of Trench	3-ft
Effective Trench Depth	4-ft

Trench Separation	8-ft
Dimensions of Leach Field Surface Plot	25-ft x 19-ft

Vineyard Irrigation System Design

When analyzing the irrigation system, the size and water demands for the vineyard must be determined prior to determining the components and requirements of components for the irrigation system. In this section, the water demand and size of the vineyard will first be addressed, followed by the requirements for the components of the irrigation system. The components and technologies that were determined to be the best fit for the vineyard are as follows:

- Above-ground drip irrigation
- Storage tank to hold irrigation water
- Pump to supply the drip irrigation system from the storage tank
- Pressure tank to supply the proper pressure to the drip irrigation system
- Submersible pump to deliver water from the creek to the storage tank

In determining the design and layout of the system, some parameters must be defined. These parameters include the size and spacing of the vines and the water demand. As instructed by our client, the irrigation system is designed to meet the water demand for 1500 vines per acre with a spacing of 6-ft between vines and 8-ft between rows for a total acreage of 1 to 2 acres. This information is used to determine the water demand per acre and the system pressure required to adequately meet these requirements.

Vineyard Water Demand

When estimating the water demand, certain assumptions needed to be made for various reasons. The primary reason for assumptions in the lack of data for the area and surrounding areas with similar climates. Therefore, data was generally taken from areas with similar climate or harsher climates to overestimate the water demand. By overestimating the water demand, we ensure that even during peak water usage the system will operate correctly and allow the vineyard to accommodate growth if needed. The true water demand will be determined by the as the vineyard is operated during the wine growing season. The assumed variables include the evapotranspiration rate and crop coefficient. These variables were taken from three areas, Safford, Tucson, and Phoenix Arizona.

Methods

First, we must determine the area that will be used for reference; a pseudo-area to represent the Cottonwood/Cornville area. The area that was selected was Jerome, AZ, and the data used for reference can be found below:

- Avg. Temperature = 60.2 °F [11]
- Avg. Precipitation = 18.79-in [11]

The two areas that were selected to have the most similar climate data from the evapotranspiration data available were Safford and Tucson, AZ. The climate data for the two areas can be found below:

Safford:

- Avg. Temperature = 63.85 °F [11]
- Avg. Precipitation = 9.67-in [11]

Tucson:

- Avg. Temperature = 70.9 °F [11]
- Avg. Precipitation = 11.62-in [11]

To better determine a reference evapotranspiration rate. The data collected for these two areas were averaged between the two for each month of the year. This maximum value from this data was then selected to be used to determine the maximum water requirement for the vineyard. The maximum evapotranspiration for taller plants is observed in July with a value of 10.48-in/mo [12]. Finally, the crop coefficient for grapevines in Arizona was found, dependent on the growing degree day (GDD) and time period during the wine season. As well, the maximum value for the crop coefficient was determined to be 0.52 [13]. In addition to the above coefficients, the minimum efficiency of the drip irrigation system was assumed. Although drip irrigation efficiency ranges from 0.8 to 0.95 and is generally assumed to be 0.9, a system efficiency of 0.8 was used [14]. The equations used in these calculations can be found in the appendix.

Using the same data sets, average values were determined to estimate the average water demand per acre of vineyard. This data is as follows:

- Evapotranspiration rate = 6.36 in/mo [12]
- Irrigation efficiency = 0.9 [14]
- Crop coefficient = 0.3875 [13]

Estimation of Water Demand

Using the above assumptions, as well as the equations listed above the water demand per vine can be determined per month and per day, assuming maximum evapotranspiration and crop coefficients. The water demand results that were determined to be the most impactful to the design of the system is listed below. The maximum water demand is:

- Water Req.= 0.227-in/d
- Gal/vine/day = 6.8-gpd/vine
- 1500 vines/acre daily demand = 10,200-gpd/acre
- 1500 vines/acre demand = 7.07-gpm/acre

The average water demand is:

- Water Req. = 2.7-in/mo
- Gal/vine/day = 2.73-gpd/vine
- 1500 vines/acre daily demand = 4,094-gpd/acre
- 1500 vines/acre demand =2.85-gpm/acre

Drip Irrigation System

A drip irrigation system was selected for a variety of reasons. These reasons include the low cost of the system, the high efficiency of the system, and the ease of access to the system. For these reasons, drip irrigation is a common method of irrigation for vineyards of our size. As well, the implementation of this system is easy and at a low installation and maintenance cost as compared to similar irrigation systems.

Dripline System

The system was analyzed to determine the acceptable head-loss, as pressure-loss, through the lateral driplines as that the system will still operate correctly. Once determining the acceptable pressure loss, with respect to the operating pressure of the dripline, the maximum lateral length can be determined. This information will assist the client when laying out the dripline to assure the system will operate as designed and the vineyard will observe a uniform irrigation rate as designed.

The analysis was performed using specific assumptions. These assumptions were made to determine a conservative dripline length to assure when the dripline network is laid out by the client. By using conservative assumptions, we can define the maximum possible pressure-loss in the system. These assumptions are as follows:

- ½-in polyethylene dripline, rated up to 60-psi [15], was used.
- The dripline operates in an acceptable pressure range between 8-psi to 50-psi, total pressure-loss must be less than 38-psi [15].
- Water demand per acre = 10,200-gpd = 425-gph = 7.08-gpm
- Spacing between rows of 8-ft
- Emitter flow rate of 0.5-gph [15].

Using the above assumptions, we can determine the flow and length per row for varying numbers of rows, depending on the number of emitters per row.

These variables can be used along with the assumptions above to first determine the flow through the dripline at various lengths. These lengths were calculated per acre for various numbers of rows. The total length of dripline required, independent of length per row, is 5,445-ft to irrigate one acre.

The demand flow for system is calculated by first determining the number of emitters per acre, or 5,445-ft of dripline, and taking the cumulative flow of all of these emitters. The flow through the system should be greater than the system demand of 7.07-gpm. The flow of the system can be determined using the following equation:

Equation 2:

$$\# \frac{\text{emitters}}{\text{acre}} \cdot \frac{\text{flow}}{\text{emitter}} = \frac{\text{flow}}{\text{acre}}$$

The flow through the system (gpm) is calculated for an emitter flow rate of 0.5-gph for varying numbers of emitters. The results of this analysis can be seen tabulated in the appendix. Based on this analysis, we have decided to use 1500 emitters/acre which produces a flow of 12.5-gpm for the entire system. The spacing between each emitter is calculated to be 3.63-ft. These results will be used for the pressure-loss analysis.

Once the observed flow through system is determined, the pressure-loss through a dripline row can be calculated for various lengths depending on the designed number of uniform rows. These lengths can be calculated using the equation listed below.

Equation 3:

$$\text{area, ft}^2 \div \text{row, ft spacing} \div \# \text{ rows} = \text{length of row}$$

The vineyard area used was one acre, 43560-ft², and a dripline row spacing of 8-ft. The length per row was calculated for a total amount of rows ranging from 20-40. Once the length of the row is determined, the pressure-loss can be calculated using equation (x) listed below [w5].

Equation 4:

$$P_L = 4.53 \cdot L \cdot (Q/C)^{1.852} \cdot D^{-4.857}$$

Using the 1500 emitters/acre, ½-in tubing, and a total design flow of 12.5-gpm we can calculate the pressure-loss for various numbers of rows. These results are tabulated below.

Table 3: Pressure-loss in Dripline

No. Rows	Length/Row, ft	Emitter/Row	GPM/Row	Pressure Loss, PSI
15	363	100	0.833	3.17
20	272.25	75	0.625	1.40

25	217.8	60	0.5	0.74
30	1815	50	0.4167	0.44
35	155.57	43	0.3583	0.28
40	136.125	38	0.3167	0.20

Using this analysis, we can determine the specifications for the design of the drip irrigation system. These are tabulated below.

Table 4: Dripline Design

Dripline tubing diameter	½-in
Emitter flow rate	0.5-gph
No. emitters per acre	1500
Spacing between emitters	3.5-ft to 3.75-ft
Length dripline per acre	5,445-ft
Length per row	<350-ft
System flow per acre	12.5-gpm

Mainline Irrigation System

The mainline irrigation system is the pipeline that will provide flow to the dripline laterals in the dripline irrigation system. The mainline will need to handle a total flow of 12.5-gpm. The analysis for

number of acceptable rows is dependent on the pressure-loss in the mainline. Assuming a mainline diameter of ¾-in and using the decrease in flow at each dripline lateral, we can calculate the pressure-loss between rows and use the sum to represent the pressure-loss through the entire mainline. The mainline length and pressure-loss can be seen tabulated below. It is assumed a 20-ft length to the first dripline lateral.

Table 5: Pressure-loss in Mainline

No. Rows	Mainline length, ft	Pressure-loss, psi
20	172	13.26
25	212	15.83
30	252	18.40
35	292	20.77
40	332	22.82

As can be seen, the pressure-loss is still acceptable up to 40 rows. However, when the system is operating at 30-psi, a pressure-loss of 22-psi could drop the pressure through the driplines below 8-psi, which is their minimum operating pressure. To ensure this is not the case, we suggest a conservative number of rows between 20-30.

Storage Tank

The storage tank that was used for this analysis is a 5000-gal storage tank with a tank height of 112-in, or about 10-ft, and a diameter of 119-in. It is comprised of a UV-resistant plastic designed for above ground storage of surface water for varying uses, including irrigation. The inlet to the tank is located at the top and aerated to the environment. The tank is not meant to be pressurized above atmospheric and hydrostatic pressure. [16]



Figure 5: 5000-gal Storage Tank [16]

Irrigation Supply Pump

After determining the sizing of the mainline, the requirements for a pump and pressure tank need to be determined for accurate sizing and selection of the components. These requirements are as follows:

- The pump must supply a minimum of 12.5-gpm to the entire irrigation system and discharge at 30-psi to 50-psi.

The pump that was selected is the Goulds J7S 3/4 HP shallow well jet pump, which can be seen in the image below [17].



Figure 6: Irrigation Supply Pump [17]

The pump was selected because it will operate at the designed flow rate under low head conditions while supplying a high pressure. The pump will need to be placed above the storage tank to allow for a minimum of a 5-ft suction lift. At 30-psi and 5-ft suction lift, the pump will supply a flow rate of 31.3-gpm [17]. At 30-psi and 5-ft suction lift, the pump will supply a flow rate of 12.5-gpm [17]. It is important that the pump can operate at 50-psi because the pressure tank will 'cut-on' the pump when it reaches 30-psi and 'cut-off' the pump once it reaches 50-psi. The irrigation pump will refill the pressure tank to supply pressure to the system and prevent the pump from overheating.

Pressure Tank

The pressure tank was selected by first determining the size required. The sizing of the pressure tank is based off how fast the pump will fill up the pressure tank. The pressure tank is comprised of a steel shell and a bladder system within it that will expand when it is filled and hold pressure. As the water is pulled from the tank by the system, the pressure will drop until 30-psi when the pump will kick back on and refill the bladder until 50-psi is met within the tank. This will keep the pressure within the system between 30-psi and 50-psi. The pressure tank that was selected has a total volume of 62-gal and a drawdown of 19.9-gal for a 30/50-psi cut-in/out [18]. With the pump selected above, the pump will refill the drawdown in about one minute. The model selected is the Amtrol WX-251 pressure tank, which can be seen pictured below.



Figure 7: Pressure Tank [18]

Submersible Pump

The final component of the irrigation system is a pump to deliver surface water from the adjacent creek to the storage tank at the top of the hill overlooking the vineyard. The analysis of the submersible pump must meet specific requirements:

- Total dynamic head of 65.4-ft, calculated using the PumpFlo Application.
- Static head of 54-ft, from bottom of creek to storage tank
- Flow well over 12.5-gpm

The submersible pump that was selected is the S-Series submersible pump by Gorman-Rupp, which can be seen pictured below [19]. The pump in question has a 2-in inlet and outlet and the total dynamic head was calculated using 2-in piping. Under these conditions, the pump will provide a flow of 53 GPM, which is well over the required flow, so the pump does not need to run often. As well, the pump curve can be seen in the appendix.



Figure 8: Submersible Pump [19]

Water Quality Analysis for Drinking Water Well

The purpose of the water quality analysis was to determine whether the septic tank of the creek have any impact on the drinking water well. The test was conducted for total nitrogen, nitrate, fecal coliform, and pH. The final results are shown in table 5 below, alongside the methods that were used to analyze the samples obtained.

Table 6: Water Quality Results

	Avg. Tap	Avg. Well	EPA Standards [20]	Methods
Total Nitrogen, mg/L	0.675	0.325	N/A	HACH 10071
Nitrate, mg/L	0.1	0.3	10	HACH 8039
Fecal Coliform, No. colonies/100-mL	0	0	0	HACH 8074
pH	7.14	N/A	6.5-8.5 (SMCL)	Hanna Meter

The total nitrogen test was backed up by another test using different samples since the first test resulted in negative values as shown in table 11 in the appendix. Therefore, the total nitrogen and nitrate results should be considered independently since they were not tested for using the same sample.

A total of six samples were collected from both the tap and the well and were tested against two independently prepared blanks. Moreover, the EPA standards includes the maximum contaminant levels (MCL) and secondary contaminant levels (SMCL). The MCL are established by EPA for primary health concerns of contaminated water to protect the public such as Total Nitrogen and Nitrate, whereas the SMCL are established for aesthetic conditions including taste, odor, and color, for example pH. All the results are within the EPA standards and regulations.

Cost of Implementation

This section includes a summary of the engineering work conducted. This section also includes a summary of the cost for engineering work as well as the cost of systems.

Summary of Engineering Work

The engineering work that has been completed includes a site investigation, site characterization, septic design type selection, irrigation design type selection, and site topographic map. The work includes the collection of survey data, soil evaluation, water testing, alternative septic system analysis and design, and irrigation system analysis and design. In addition to the technical work, administrative work such as team meetings, meeting with clients, and time spent collecting quotes and contacting distributors is included.

The Gantt Chart from the project proposal is included in the attachments.

Summary of Engineering Costs

Table 6 displays the summary of engineering costs. The hours allocated to the professional engineer are the hours the team spent meeting with the technical advisor and grading instructor. The hours allocated to the engineer in training are the hours the team spent on the research and design aspect of the project. The tech hours represent the time spent in the lab conducting the water quality analysis, as well as the time spent collecting samples. Lastly, the administrative assistant hours are representative of the time spent contacting distributors, manufacturers, and any clerical work the team performed. As a survey of the site was not within the scope of the project, the team hired a subcontractor.

Table 7: Cost of Engineering Work [21]

1.0 Personnel	Classification	Hours	Rate (\$/hr)	Cost
	Professional Engineer	15	\$195.00	\$2,925.00
	Engineer In Training	450	\$67.00	\$30,150.00
	Tech	5	\$48.00	\$240.00
	Administrative Assistant	200	\$56.00	\$11,200.00
	Total Personnel Cost			\$44,515.00
2.0 Travel	3 Site Visits @ 110 mi		\$0.40/mi	\$132.00
3.0 Subcontract	Site Survey			\$1,000
4.0 Total		670		\$45,647.00

Table 7 displays a summary of the estimated total cost for the system design. To obtain these estimated quotes, the team contacted manufacturers and distributors of the selected systems. These estimations are likely to change, as site visits and further testing is required prior to the determination of a final quote.

Table 8: Overall Project Proposed Costs

Component	Estimated Quote
Septic System [22]	\$ 12,000
Septic Installation [22]	\$ 10,000

Submersible Pump (Creek) [23]	\$ 6,000
Irrigation System (1 acre) [15]	\$ 1,075
5,000-Gal Storage Tank [16]	\$ 2,000
Storage Tank Shipping Cost [16]	\$ 2,666
Irrigation Pump and Pressure Tank [17] [18]	\$ 1,159
Estimated Total:	\$ 34,900

Conclusion

The project deliverables are designing an alternative septic system, designing an irrigation system, performing a water quality analysis of the well, and creating a 1ft topographic map. The alternative septic system was chosen to be an aerobic system provided by Air Environmental Industries. The system that was selected is in compliance with the A.A.C. for an area within the 100-year flood plain and can be implemented on this specific site. The irrigation system was designed for a growing vineyard using water demand estimations and the topographic qualities of the site. The components that were selected include a drip irrigation system, storage tank, irrigation supply pump, pressure tank, and submersible pump. The water quality analysis of the well showed that the drinking water is clean, and the creek and current septic tank have no direct impact on the quality of the water. The project was completed on-time with only minor setbacks.

References

- [1] Google, "Google Maps," 2017. [Online]. Available: <https://www.google.com/maps/place/2955+N+Echo+Canyon+Rd,+Cornville,+AZ+86325/@3>. [Accessed 13 November 2017].
- [2] Yavapai County Development Services, "Alternative System Submittal Requirements," [Online]. Available: <http://www.yavapai.us/Portals/34/Reference%20Materials/AlternativeSetpicSystemSubmittalRequirements.pdf>. [Accessed 13 November 2017].
- [3] "G&M Tank Co," GM Tank Co., [Online]. Available: <http://gmtankco.com/aerobic/>. [Accessed 29 March 2018].
- [4] J. C. Converse and E. Tyler, "Wisconsin Mound Soil Absorption System: Siting, Design, and Construction Manual," 2000.
- [5] "Sequencing Batch Reactor Septic System Designs," [Online]. Available: http://inspectapedia.com/septic/Sequencing_Batch_Reactor_Septic_Design.php. [Accessed 8 May 2018].
- [6] USGS, "Irrigation: Drip/Microirrigation," [Online]. Available: <https://water.usgs.gov/edu/irdrip.html>.
- [7] F. R. Lamm and D. H. Rogers, "Longevity and Performance of a Subsurface Drip Irrigation System," *American Society of Agricultural and Biological Engineers*, vol. 60, no. 3, pp. 931-939, 2017.
- [8] D. Reich, R. Godin, J. Chavez and I. Broner, "Subsurface Drip Irrigation (SDI)," August 2014. [Online]. Available: <http://extension.colostate.edu/docs/pubs/crops/04716.pdf>. [Accessed 8 May 2018].
- [9] USGS, "Irrigation: Typical sprinkler (spray) irrigation," 2 December 2016. [Online]. Available: <https://water.usgs.gov/edu/irsprayhigh.html>. [Accessed 13 November 2017].
- [10] USGS, "Irrigation Water Use: Low-energy spray irrigation," 9 December 2016. [Online]. Available:

<https://water.usgs.gov/edu/irlepa.html>. [Accessed 13 November 2017].

- [11] "Climate Arizona," U.S. climate data, [Online]. Available: <https://www.usclimatedata.com/climate/arizona/united-states/3172>. [Accessed 24 March 2018].
- [12] P. Brown, "Standardized Reference Evapotranspiration: A New Procedure for Estimating Reference Evapotranspiration in Arizona," College of Agriculture and Life Sciences, University of Arizona, Tucson, 2005.
- [13] D. C. Slack and E. C. Martin, "Irrigation Water Requirements of Wine Grapes in the Sonoita Wine Growing Region of Arizona," Department of Agricultural and Biosystems Engineering, University of Arizona, Tucson, 1999.
- [14] M. Moyer, R. T. Peters and R. Hamman, "Irrigation Basics for Eastern Washington Vineyards," Washington State University Extension, Pullman, 2013.
- [15] "Standard Drip Irrigation Kit for Vineyard," DripDepot, [Online]. Available: <https://www.dripdepot.com/product/standard-drip-irrigation-kit-for-vineyard>. [Accessed 23 April 2018].
- [16] "5000 Gallon Plastic Water Storage Tank," The Tank Depot, [Online]. Available: http://www.tank-depot.com/productdetails.aspx?part=N-42044&gclid=Cj0KCCQjwh7zWBRCiARIsAId9b4r7cRVZMoFemeVuZRY3g9_64btgyUXtGIGaF3cPV6_YNb_xxKKxuk8aAjHEELw_wcB. [Accessed 23 April 2018].
- [17] "Goulds J7S, 3/4HP, Single Nose Shallow Well Jet Pump," Aquascience.com, [Online]. Available: <http://www.aquascience.net/goulds-j7s-single-nose-shallow-well-jet-pump-3-4hp>. [Accessed 7 May 2018].
- [18] "Amtrol Well-X-Trol WX-251, 62 Gallon, Water Pressure Tank," Aquascience.com, [Online]. Available: <http://www.aquascience.net/amtrol-well-x-trol-62-gallon-water-system-pressure-tank-wx-251>. [Accessed 7 May 2018].
- [19] "S-Series," Gorman Rupp, [Online]. Available: <https://www.grpumps.com/product/pump/S-Series-Widebase-Submersible>. [Accessed 7 May 2018].
- [20] Environmental Protection Agency, "National Primary Drinking Water Regulations," USEPA, [Online]. Available: <https://www.epa.gov/ground-water-and-drinking-water/national-primary>

drinking-water-regulations. [Accessed 27 March 2018].

[21] D. Bero, "Cost of Staffing," [Online]. Available: <http://bblearn.nau.edu/>. [Accessed March 2018].

[22] Aim Environmental Industries, *Quote Estimation*, D. Norfleet.

[23] I. Phoenix Pumps, Interviewee, *Quote Estimation*. [Interview]. 16 April 2018.

[24] "MicroFAST," Florida Onsite Systems & Design, [Online]. Available: <http://floridaonsitesystemsanddesign.com/microfast/>. [Accessed 23 April 2018].

[25] A. E. Industries, Interviewee, *Quote Estimation*. [Interview]. 16 April 2018.

Appendices

Table 9: On-site Percolation Test Times

Test Number	Time for Percolation test (min)
1	10:31
2	17:52
3	18:57

Table 10: Tap Water and Creek Hanna Meter Readings

	Tap	Creek
pH	7.14	8.78
Temperature (°C)	18.47	7.62
Conductivity (µS/cm)	462	309

Table 11: Total Nitrogen Sample Testing Data

Test Source (mg/L)	Test 1	Test 2
Blank	0	0
Well	-0.6	-0.2
Tap	1	0.1

Creek	-0.2	N/A
-------	------	-----

Table 12: Nitrate Sample Testing Data

Source	Results (mg/L)
Blank	0
Tap	0.1
Well	0.3

Table 13: Fecal Coliform Testing Data

Water Source	Number of colonies
Well (No Dilution)	0
Well (1:5 Dilution)	0
Tap (No Dilution)	0
Creek (No Dilution)	0
Creek (1:10 Dilution)	0
Creek (1:100 Dilution)	0

Table 14: Decision Matrix for Irrigation Design Selection

Criteria	Drip Irrigation	Sub-Surface Drip	Low-Elevation Spray
Crop Yield	8	8	6
Water Usage	9	9	7
Water Loss	8	9	7
Installation	8	6	8
Maintenance	9	7	7
Total score	42	39	35

Table 15: Flow in Irrigation System per No. of Emitters

No. Emitters	Flow in System, gpm
1000	8.33
1250	10.42
1500	12.50
1750	14.58
2000	16.67

Equation 5: Water Demand Equations [14]

$$H_2O \text{ Req.} = \frac{(ET \cdot K_c)}{eff}$$

Where:

ET = evapotranspiration rate (in/mo)

K_c = Crop coefficient

eff = Drip irrigation efficiency

$$gal/vine/time = (0.623)(H_2O \text{ Req., in})(row \text{ spacing, ft})(vine \text{ spacing, ft})$$

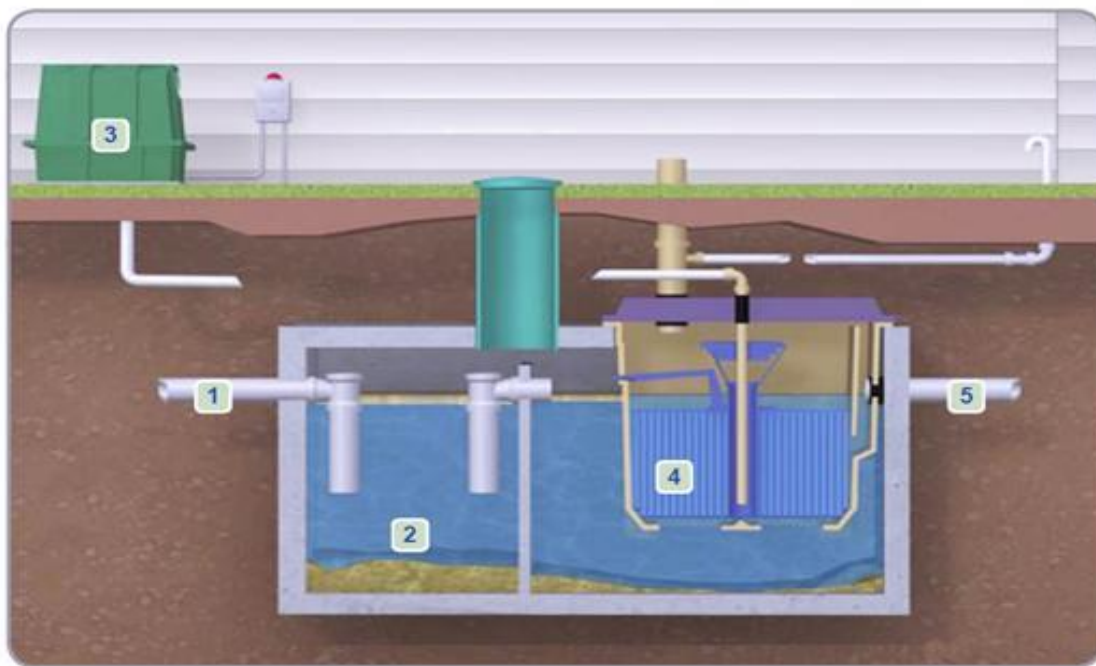

Figure 9: MicroFAST Aerobic Treatment Unit [24]

Table 16: Description of Numbered Locations on MicroFAST System Figure

Numbered Location on Figure	System Function
1	Influent from House
2	Settling Chamber
3	Aeration Pump
4	Fixed Bacteria Media
5	Effluent to disposal works



2018

Name	Begin date	End date
Task 1.0 Site Investigat...	1/27/18	1/28/18
Task 1.1 Site Survey	1/27/18	1/28/18
Task 1.2 On-site W...	1/28/18	1/28/18
Task 1.3 Sample C...	1/28/18	1/28/18
Task 2.0 Off-site Tech...	1/29/18	2/4/18
Task 2.1 Water An...	1/29/18	1/30/18
Task 2.2 Soil Testin...	1/31/18	2/1/18
Task 2.3 Site Topo...	2/2/18	2/4/18
Complete Topogr...	2/5/18	2/5/18
Task 3.0 Alt Septic Syst...	2/5/18	3/25/18
Task 3.1 Complian...	2/5/18	2/22/18
Task 3.2 Technical ...	2/23/18	3/18/18
Task 3.3 Evaluatio...	3/19/18	3/25/18
Task 4.0 Irrigation Syst...	2/5/18	3/25/18
Task 4.1 Operations	2/5/18	2/17/18
Task 4.2 Evaluatio...	2/13/18	3/4/18
Task 4.3 System A...	2/24/18	3/25/18
Task 5.0 System Design	3/26/18	4/19/18
Task 5.1 Septic Sys...	3/26/18	4/19/18
Complete Septic S...	4/20/18	4/20/18
Task 5.2 Irrigation ...	3/26/18	4/19/18
Complete Irrigatio...	4/20/18	4/20/18
Task 6.0 Project Mana...	1/27/18	4/29/18
Task 6.1 Risk Asses...	2/5/18	3/25/18
Task 6.2 Coordinat...	1/27/18	3/22/18
Task 6.3 Schedule ...	1/27/18	2/5/18
Task 6.4 Resource ...	1/27/18	2/25/18
Task 6.5 Deliverables	4/20/18	4/29/18

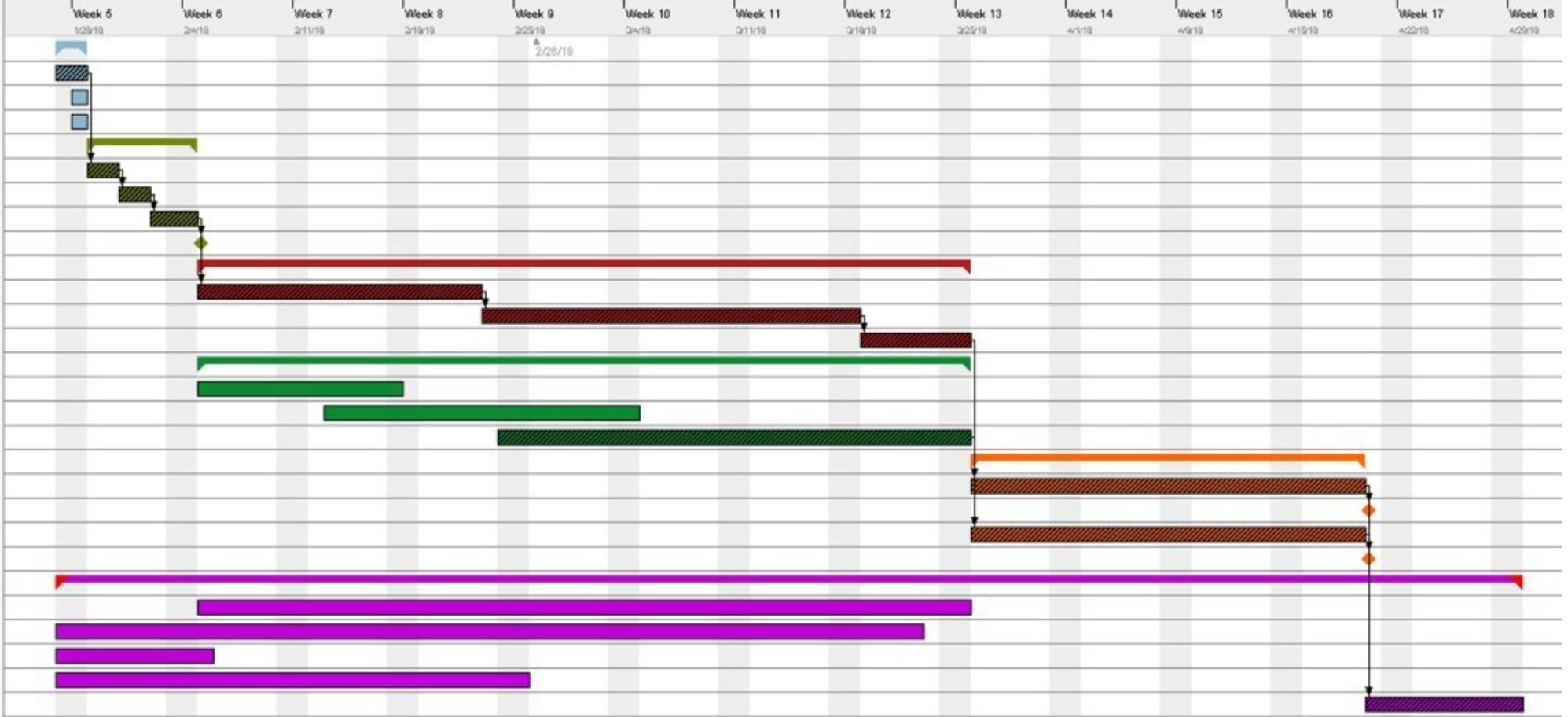

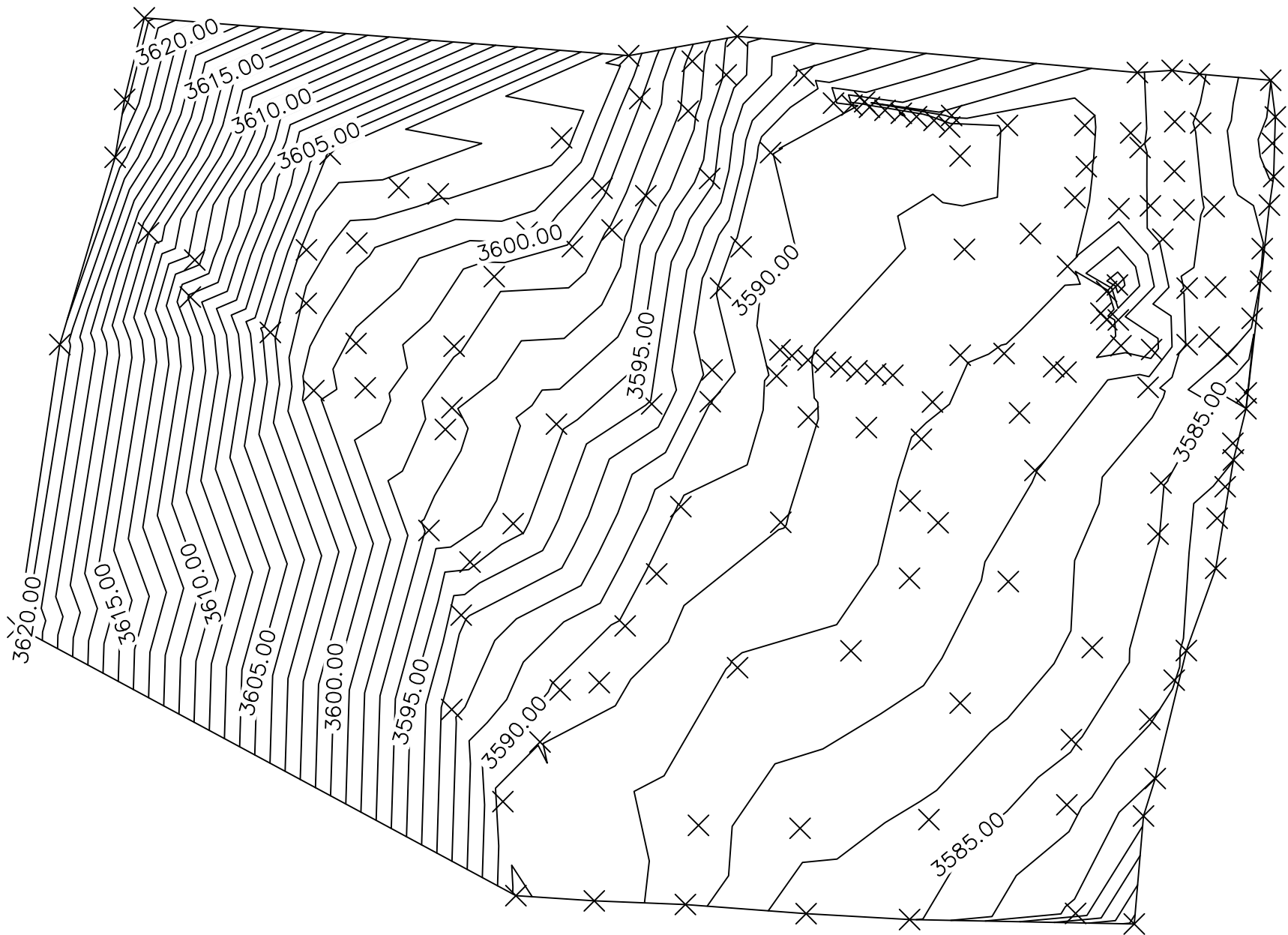

PROJECT NAME CENE-486C ALT-SEPTIC TEAM

DATE 25 FEB 17

BY WILL RICHARDSON

DRAWING NO.

NOTES

SITE TOPOGRAPHIC MAP

△ N/A
△ N/A

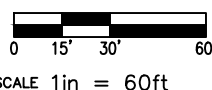

01

OF 02

REV N/A

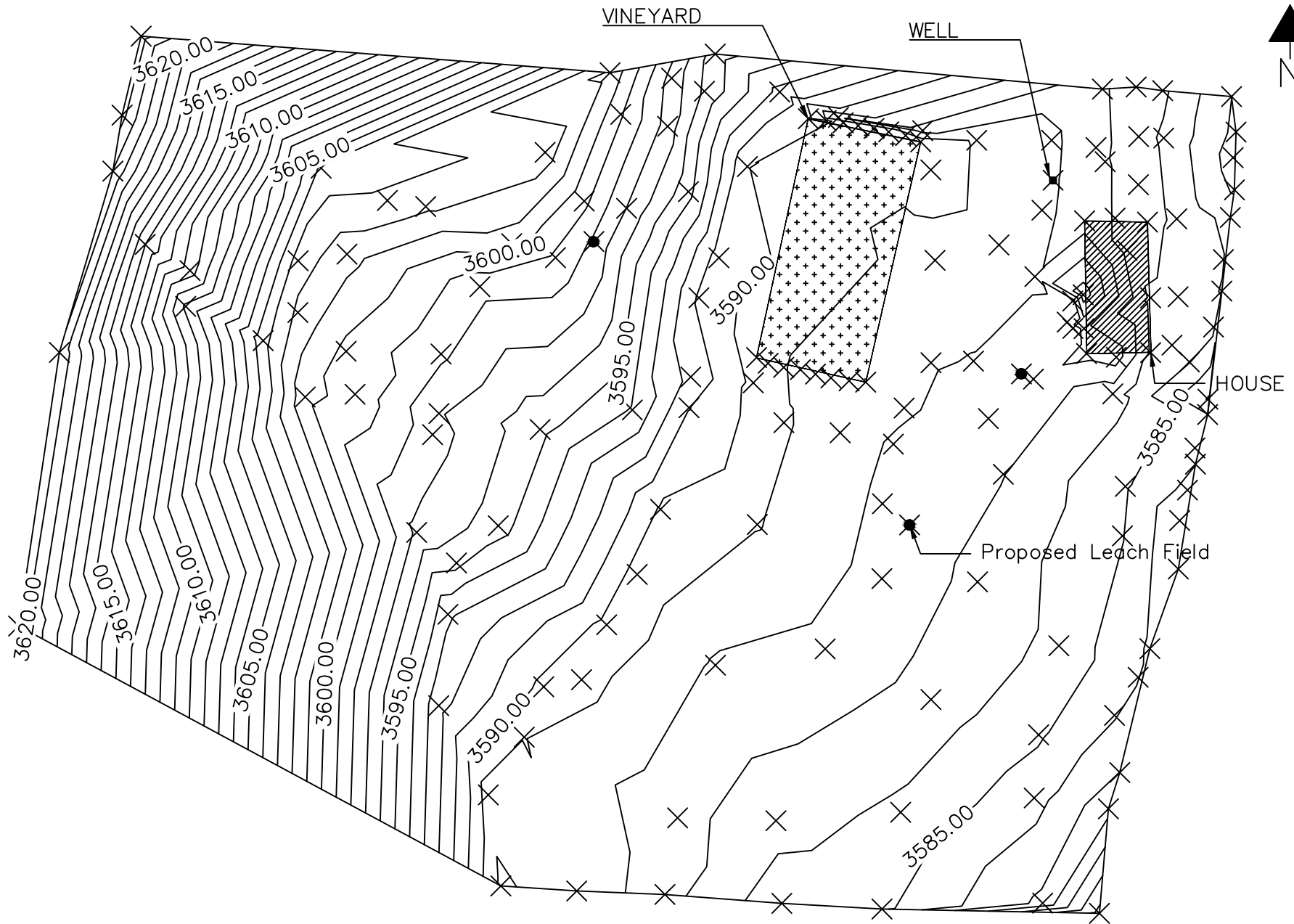

PROJECT NAME CENE-486C ALT-SEPTIC TEAM

DATE 25 FEB 17

BY WILL RICHARDSON

DRAWING NO.

NOTES

SITE TOPO & FEATURES

▲ 24 APR 18



02





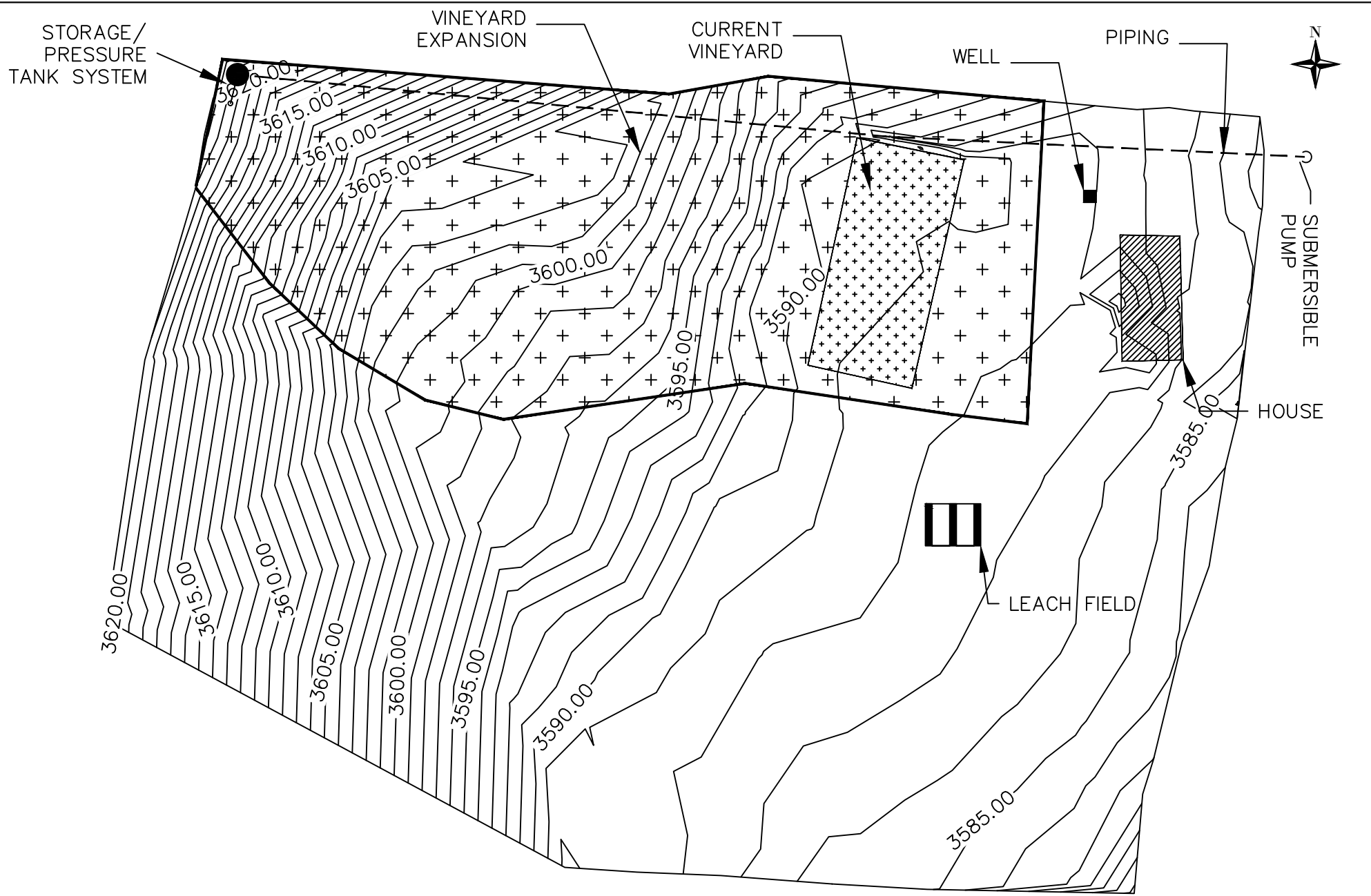

- PERC SAMPLE LOCATION
- GROUNDWATER WELL
- ▨ HOUSE
- ⊞ CURRENT VINEYARD

▲ N/A

SCALE 1in = 60ft

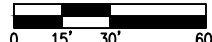
OF 02 REV 01



PROJECT NAME CENE-486C ALT-SEPTIC TEAM	DATE 24 APR 18	BY WILL RICHARDSON	DRAWING NO. 03	NOTES -SUBMERSIBLE PUMP AND PIPING ARE NOT TO SCALE. -AREA AROUND VINEYARD SHOWS EXPECTED VINEYARD EXPANSION.
VINEYARD & IRRIGATION SYSTEM	 N/A  N/A	 SCALE 1in = 60ft	OF 03 REV N/A	 GROUNDWATER WELL  HOUSE  CURRENT VINEYARD

Project Site - 2ft Topo & Property Dimensions

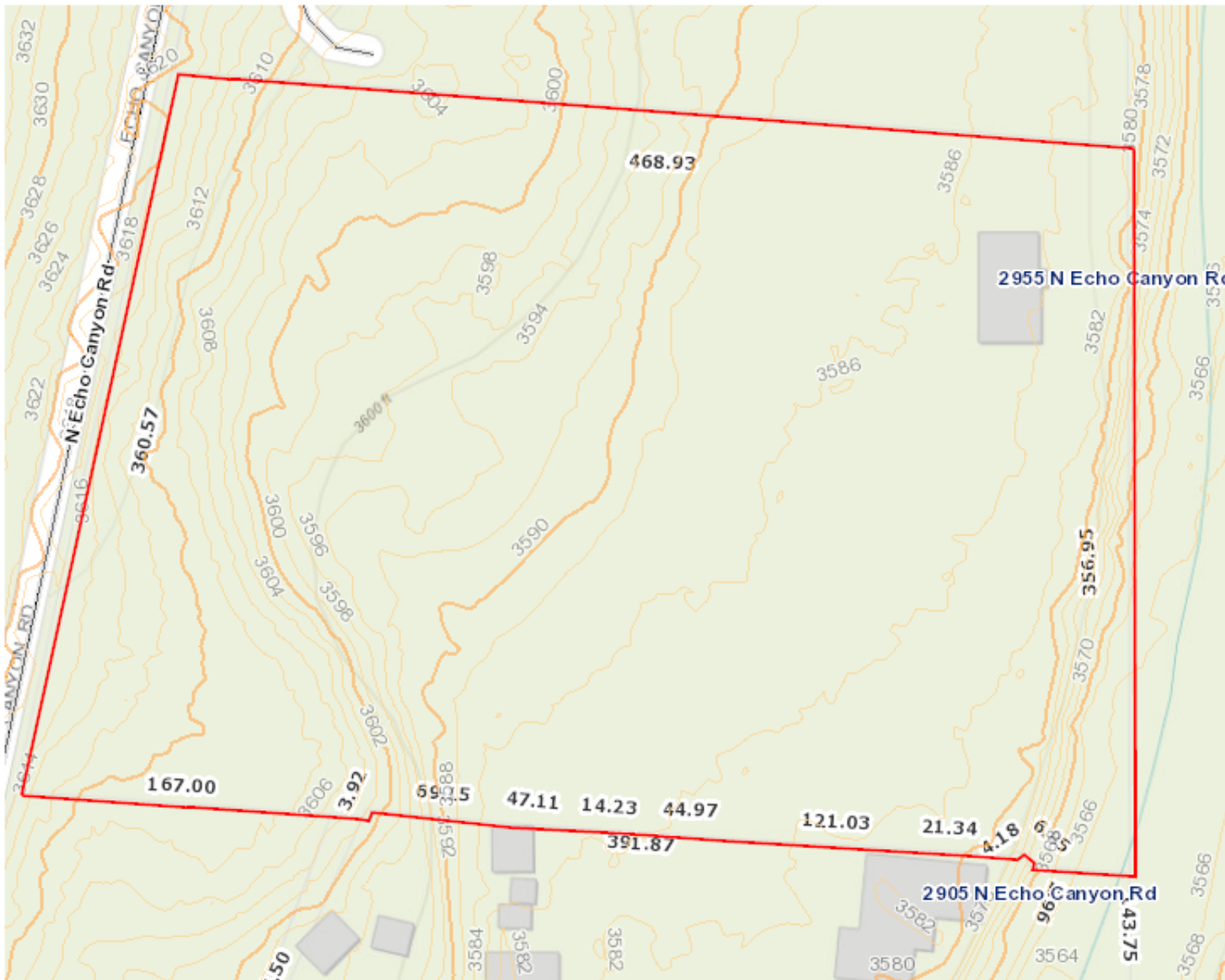

- ### Legend
- City Boundaries
 - Cottonwood
 - Peoria
 - Prescott
 - Sedona
 - Camp Verde
 - Chino Valley
 - Clarkdale
 - Dewey-Humboldt
 - Jerome
 - Prescott Valley
 - Wickenburg
 - County Boundary
 - Counties
 - Major Roads
 - Interstate
 - State Highways
 - Major Roads
 - Road Centerlines
 - Page Springs Cornville
 - 10 FT
 - 2 FT
 - City Boundaries
 - Cottonwood
 - Peoria
 - Prescott
 - Sedona
 - Camp Verde
 - Chino Valley
 - Clarkdale
 - Dewey-Humboldt
 - Jerome
- Legend truncated...



Disclaimer: Map and parcel information is believed to be accurate but accuracy is not guaranteed. No portion of the information should be considered to be, or used as, a legal document. The information is provided subject to the express condition that the user knowingly waives any and all claims for damages against Yavapai County that may arise from the use of this data.

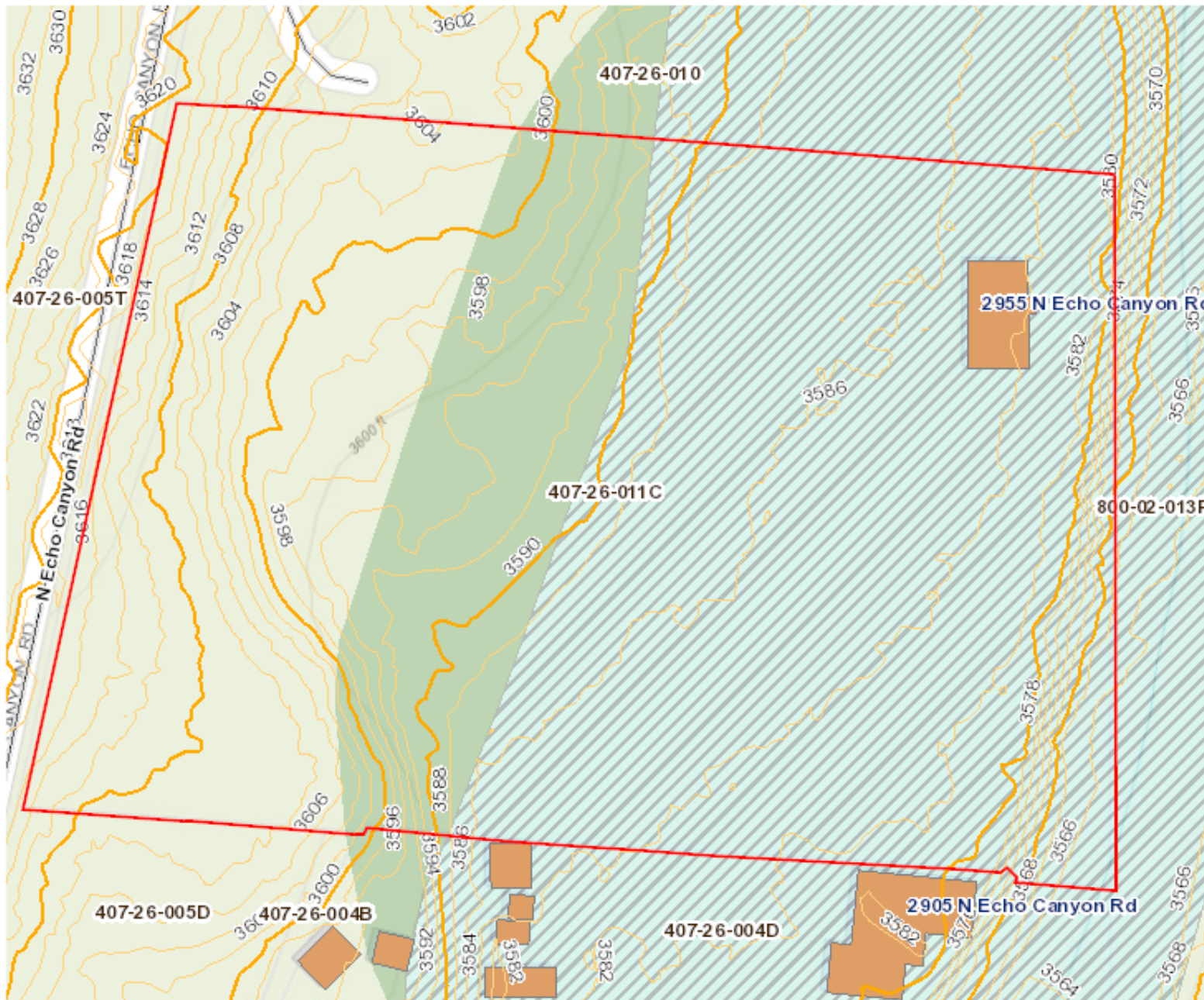

- ### Legend
- City Boundaries
 - Cottonwood
 - Peoria
 - Prescott
 - Sedona
 - Camp Verde
 - Chino Valley
 - Clarkdale
 - Dewey-Humboldt
 - Jerome
 - Prescott Valley
 - Wickenburg
 - County Boundary
 - Counties
 - Current FEMA Flood Zone
 - Zone A or AE, 1% annual
 - Zone AE, 1% annual chan
 - Zone A 1% annual chan
 - Zone AE Floodway, 1% a
 - Zone D, Area of undeter
 - Zone Shaded X, Area of
 - Zone AH, Flood depths
 - Zone AO, Flood depths
 - Zone X Levee, the levee
 - Buildings 2011
 - Major Roads
 - Interstate
 - State Highways
 - Major Roads
 - Road Centerlines
 - Page Springs Cornville
 - 10 FT
- Legend truncated...

Disclaimer: Map and parcel information is believed to be accurate but accuracy is not guaranteed. No portion of the information should be considered to be, or used as, a legal document. The information is provided subject to the express condition that the user knowingly waives any and all claims for damages against Yavapai County that may arise from the use of this data.

